



**SafetyLink®**

*Innovative  
Fall Protection*

# TUFF-BLOC

**SELF RETRACTING LIFELINE**

## USER INSTRUCTION

**FIGURE 1**



PRODUCT CODE	FUNCTIONAL LENGTH (m)	RETRACTED LENGTH (mm)	HEIGHT (mm)	WIDTH (mm)	WEIGHT (kg)
TUFF-BLOC006	6.0	730	100	180	4.0
TUFF-BLOC010	10.0	750	100	210	4.9
TUFF-BLOC015	15.0	800	110	230	7.3
TUFF-BLOC020	20.0	850	110	290	9.8

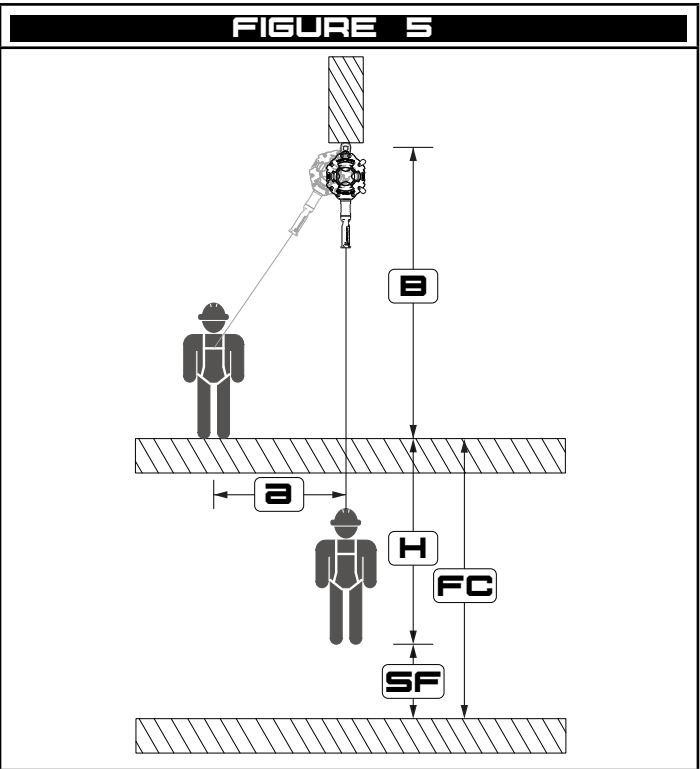
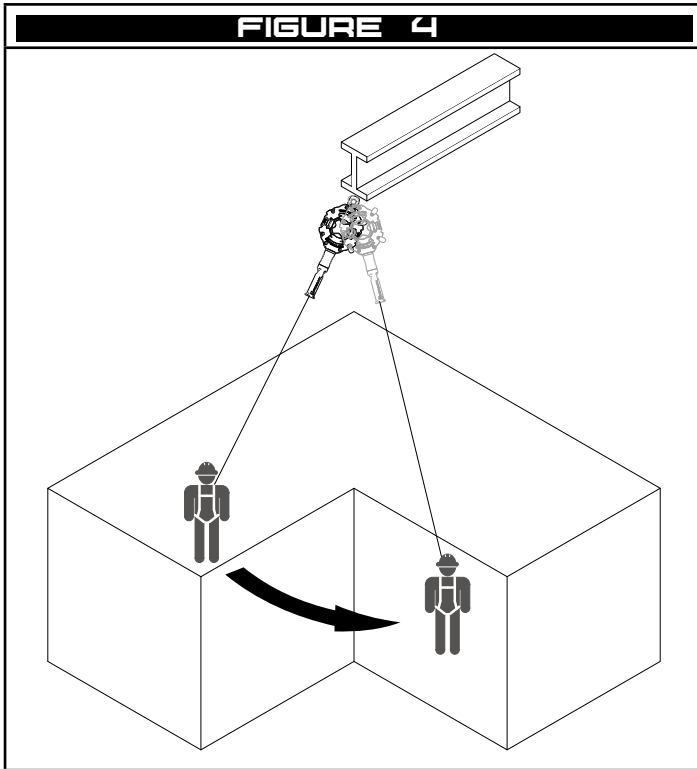
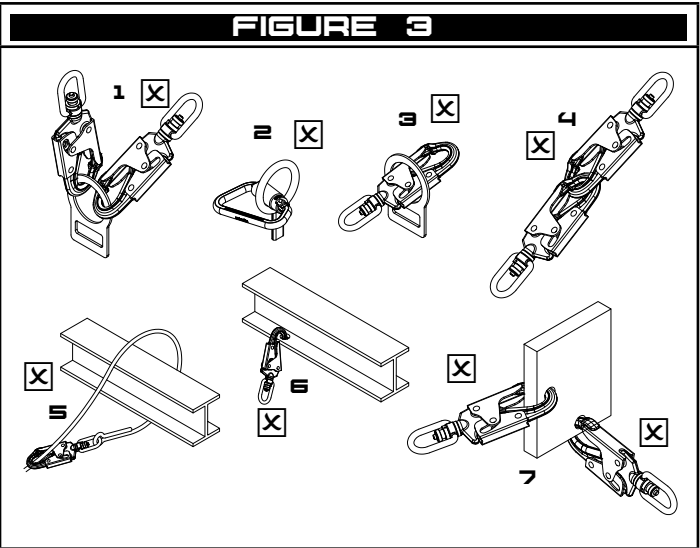
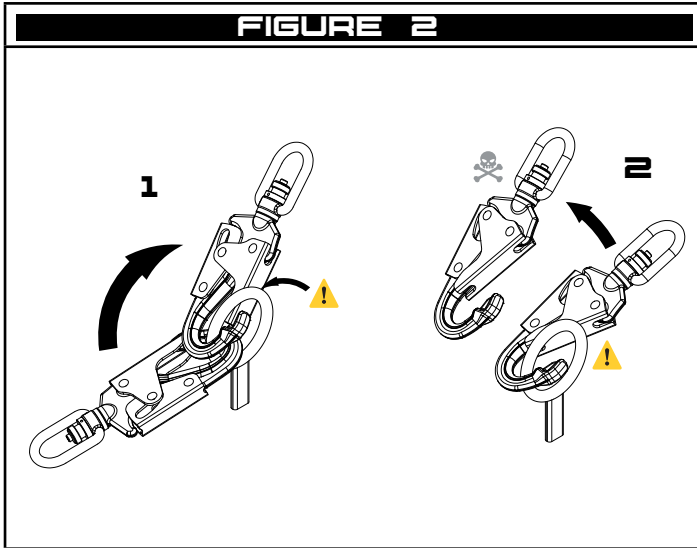

**FIGURE 6**

<b>100kg</b>		<b>A - HORIZONTAL DISTANCE (m)</b>						
		<b>0.0</b>	<b>1.0</b>	<b>2.0</b>	<b>3.0</b>	<b>4.0</b>	<b>5.0</b>	<b>7.0</b>
<b>B - VERTICAL DISTANCE ABOVE SURFACE (m)</b>	<b>2.0</b>	0.6	0.8	☒	☒	☒	☒	☒
	<b>4.0</b>	0.6	0.7	1.1	☒	☒	☒	☒
	<b>6.0</b>	0.6	0.7	0.9	1.3	☒	☒	☒
	<b>8.0</b>	0.6	0.7	0.8	1.1	1.5	☒	☒
	<b>10.0</b>	0.6	0.6	0.8	1.0	1.4	1.8	2.8
	<b>12.0</b>	0.6	0.6	0.8	1.0	1.2	1.6	2.5
	<b>14.0</b>	0.6	0.6	0.7	0.9	1.2	1.5	2.3
	<b>16.0</b>	0.6	0.6	0.7	0.9	1.1	1.4	2.1
		<b>C - FALL DISTANCE (m)</b>						

<b>140kg</b>		<b>A - HORIZONTAL DISTANCE (m)</b>						
		<b>0.0</b>	<b>1.0</b>	<b>2.0</b>	<b>3.0</b>	<b>4.0</b>	<b>5.0</b>	<b>7.0</b>
<b>B - VERTICAL DISTANCE ABOVE SURFACE (m)</b>	<b>2.0</b>	0.8	1.0	☒	☒	☒	☒	☒
	<b>4.0</b>	0.8	0.9	1.4	☒	☒	☒	☒
	<b>6.0</b>	0.8	0.9	1.1	1.6	☒	☒	☒
	<b>8.0</b>	0.8	0.9	1.0	1.4	1.9	☒	☒
	<b>10.0</b>	0.8	0.8	1.0	1.3	1.8	2.3	3.5
	<b>12.0</b>	0.8	0.8	1.0	1.3	1.5	2.0	3.1
	<b>14.0</b>	0.8	0.8	0.9	1.1	1.5	1.9	2.9
	<b>16.0</b>	0.8	0.8	0.9	1.1	1.4	1.8	2.6
<b>H - ARREST DISTANCE (m)</b>								

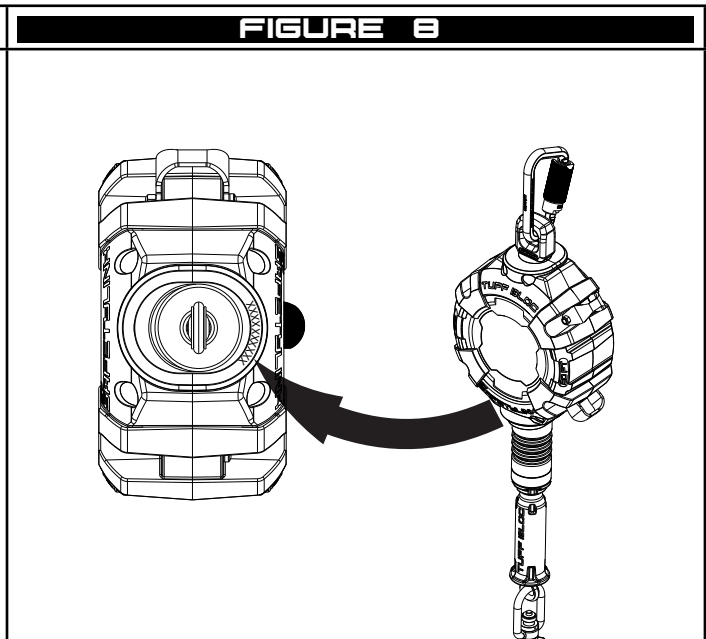
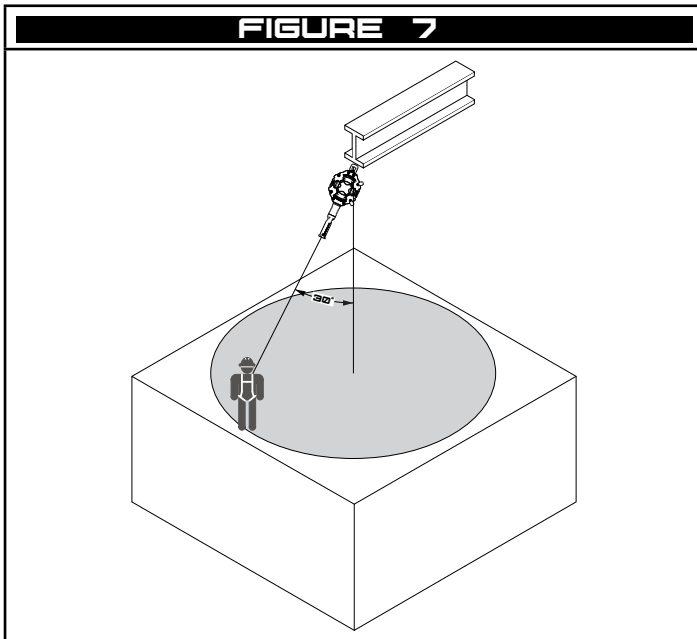

**FIGURE 9**

<b>A - PRODUCT CODE</b>	<p style="text-align: center;">TUFF-BLOC</p> <p style="text-align: center;">Product Code: TUFF-BLOC006</p> <p style="text-align: center;">CE2777 EN360:2002</p>
<b>B - CHECK FUNCTION BEFORE USE</b>	
<b>C - SCAN QR CODE FOR USER MANUAL</b>	
<b>D - OPERATING RANGE</b>	
<b>E - DO NOT ATTEMPT TO MODIFY</b>	
<b>F - USER WEIGHT RATING</b>	
<b>G - STANDARD AND CERTIFICATION MARK</b>	
<b>H - READ AND FOLLOW INSTRUCTIONS</b>	

FIGURE 10



**TUFF-BLOC**  
*Self Retracting Lifeline*  
SafetyLink.com  
54 Bonville Ave | Thornton  
NSW 2322 | Australia

**TUFF-BLOC**

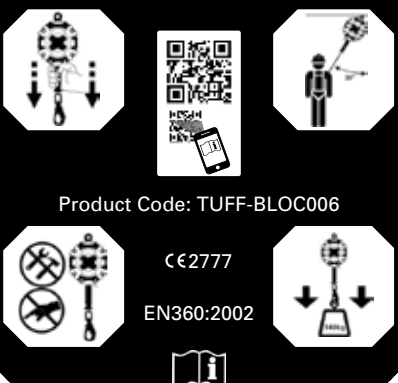

Product Code: TUFF-BLOC006  
CE2777  
EN360:2002



**TUFF-BLOC**  
*Self Retracting Lifeline*  
SafetyLink.com  
54 Bonville Ave | Thornton  
NSW 2322 | Australia

**TUFF-BLOC**

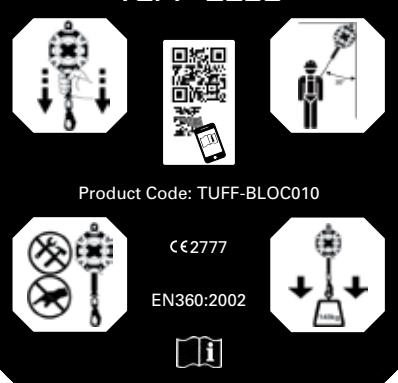

Product Code: TUFF-BLOC010  
CE2777  
EN360:2002



**TUFF-BLOC**  
*Self Retracting Lifeline*  
SafetyLink.com  
54 Bonville Ave | Thornton  
NSW 2322 | Australia

**TUFF-BLOC**

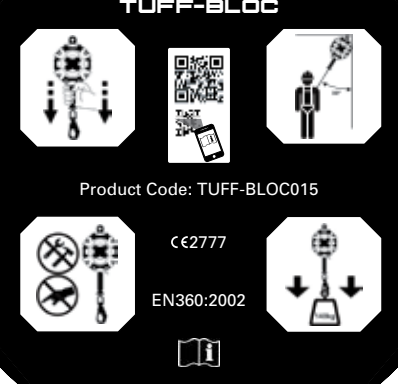

Product Code: TUFF-BLOC015  
CE2777  
EN360:2002



**TUFF-BLOC**  
*Self Retracting Lifeline*  
SafetyLink.com  
54 Bonville Ave | Thornton  
NSW 2322 | Australia

**TUFF-BLOC**

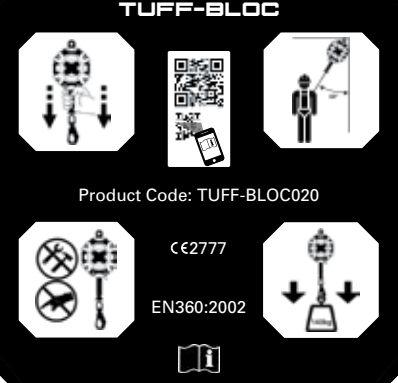

Product Code: TUFF-BLOC020  
CE2777  
EN360:2002

# 1 Specification

## 1.1 Description

The SafetyLink TUFF-BLOC is a Self Retracting Lifeline suitable for use as part of a personal fall protection system. The TUFF-BLOC shall be used in the vertical or near vertical orientation. The TUFF-BLOC shall always be used to limit free fall to less than 600mm (2ft).

If this product is resold outside of the original country of destination the reseller shall provide this instruction for safe use, maintenance and periodic examination and instructions for repair in the language of the country in which the product is to be used.

## 1.2 Standard

The Self Retracting Lifeline's listed on the front of this manual are certified to EN360:2002.

EU Declaration can be found at <https://www.safetylink.com>

## 1.3 User Rating

The TUFF-BLOC Self Retracting Lifeline is rated for user's up to 140kg (310lb).

## 1.4 Anchor

When selecting an anchor for use with the TUFF-BLOC Self Retracting Lifeline, consider the local standards and regulations. The anchor selected shall be rated to a minimum of 12kN (2700lb) and be mounted above the area of work to limit free fall.

## 1.5 Material Specification

	COMPONENT	DESCRIPTION
1	Housing	Over molded nylon
2	Handle	Polyester
3	Line	7x19 Galvanised steel cable, 4.7MM
4	Connector	Double action steel karabiner, 41kN Body, 16kN Gate
5	Connector	Double action steel snap hook, 23kN Body, 16kN Gate
6	Ferrule	Aluminium

# 2 Limitations of Use

## 2.1 Fall Clearance

When planning your fall protection system, it is important to accurately assess all components of your system in order to avoid injury. Figure 5 and Figure 6 provides guidance on how to calculate fall clearance. In Figure 5, A represents the horizontal distance the user is from the anchor, B represents the vertical distance the equipment is above the working surface, H (arrest distance) represents the alignment and deployment of the Self Retracting Lifeline as well as the estimated D-ring side of the harness and can be found in Figure 6, SF represents the recommended safety factor of 1m, FC represents the total allowable fall clearance. For safe use FC shall always be greater than  $H + SF$ .

## 2.2 Swing Fall

Working at a distance from the anchor point or off centre of a horizontal line or rail may cause a swing fall. See Figure 4. Fall protection systems shall be setup in such a way to limit swing fall.

**⚠ The force of striking an object during a swing fall may result in serious injury or death.**

## 2.3 Locking

For this equipment to lock and arrest a fall, a certain velocity must be achieved. Working on a sloped surface, in a tight space or on a moving granular substance (sand, grain etc.) may impede a fall to a point where the product fails to operate correctly. Ensure there is a clear path to allow the product to lock correctly.

## 2.4 Hazards

Use of this equipment in the presence of hazards may cause damage to the equipment and/or result in the function of the equipment being impeded. These hazards include but are not limited to; extreme temperature, sharp edges, chemical reagents, electrical conductivity, abrasion, cutting, climatic exposure and rotating or moving machinery.

## 2.5 Training

It is essential that all users are trained in the proper inspection, setup and use of this equipment. It's the responsibility of the user to ensure they are trained in the correct use of this equipment and understand the limitations of its use.

**⚠ *Incorrect use of this equipment may result in serious injury or death.***

## 2.6 Rescue

It is the responsibility of the user of this equipment and their employer to have a suitable rescue plan and the ability to implement it at any time during setup and use of this equipment.

# 3 Connections

## 3.1 Making Connection

Only make compatible connections. Always ensure connectors close and lock correctly before use. Below and Figure 3 are examples of unsuitable connections;

- 1 To an anchor or D-ring which has another connector attached.
- 2 In a position that will apply load to the gate mechanism.
- 3 By passing the connection through the attachment.
- 4 Connecting a connector to another connector.
- 5 Around a structure and back to the lifeline.
- 6 To an attachment that will limit the function of the gate.
- 7 To a location that will not load the connector as designed.

## 3.2 Compatibility of Connections

Connection made to and with this equipment shall be compatible. Connector shall be compatible shape, size and equivalent rating in order to ensure a compatible connection is made. Incompatible connections may cause loading of the gate mechanism leading to unintentional disengagement. See Figure 2. Connectors shall be compliant with EN362 and auto closing and locking.

**⚠ *Making incompatible or unsuitable connection may result in unintentional disengagement of the connector resulting in serious injury or death.***

## 4 Use

### 4.1 Planning

Before starting work, plan your working at heights and rescue systems by accounting for all hazards present in the work place and allowing for the available fall clearance. Ensure all users are fit, healthy and capable of safely operating this equipment as well as implementing the rescue plan.

### 4.2 Anchorage Selection

The anchor selected shall be capable of sustaining the loads outlined in Section 1.4. The anchor selected shall be as close to directly over the work location as possible to limit swing fall and reduce the required fall clearance.

### 4.3 Working Range

The TUFF-BLOC Self Retracting Lifeline should be used up to a maximum of 30 degrees off the centreline of the product, see Figure 7.

### 4.4 Connection to the Anchor

The TUFF-BLOC is supplied with a double action steel karabiner for connecting to the anchor. This connector may not be suitable for connecting to all anchors. If an alternative connector is used, ensure the load ratings are equivalent to the item supplied and that the connector is compatible with the TUFF-BLOC and the selected anchor.

**⚠ Use of incompatible connectors may lead to forced roll out and unintentional disconnection.**

### 4.5 Connection to the User

The TUFF-BLOC is supplied a double action snap hook for connecting to a full body harness. The snap hook should be connected to the rear dorsal d-ring / attachment point of the harness. For ladder climbing application, the connection should be made to the sternal attachment point.

**⚠ This product shall only ever be used in conjunction with a full body harness. Body belts and lower body harnesses are not permitted.**

**⚠ Always consult the harness manufacturer's instruction to ensure the harness is suitable for use with this equipment.**

**⚠ During operation of this equipment, never allow the cable to return to the housing by completely releasing the cable. Always return the cable in a controlled manner, releasing the cable may damage the product.**

**⚠ During normal operation the cable shall be taut and in a straight line back to the housing. Do not wrap the cable around obstructions.**

**⚠ Do not knot, clamp or otherwise prevent the cable from returning to the housing.**

**⚠ Only ever operate this equipment within the allowable operation range specified in this instruction, see Figure 7.**

## 5 Storage, Transport and Maintenance

### 5.1 Storage and transport

This equipment shall be stored and transported in a cool, dry environment, away from any hazards and out of direct sunlight.

### 5.2 Maintenance

The TUFF-BLOC is serviceable only by trained and authorised service centres. Contact SafetyLink to find your nearest available service centre. The service interval will be determined by the condition in which it is used. Harsher conditions will require more frequent servicing. The equipment may remain in service until it fails an inspection or is involved in a fall.

**⚠ *This product is a complete system, do not attempt to modify, disassemble or substitute any components of this product.***

If the TUFF-BLOC becomes wet during use, allow it to dry naturally away from a direct heat source and out of direct sunlight.

**⚠ *Do not store this product when wet. Allow the product to dry and conduct a pre-use inspection prior to returning the item to service.***

### 5.3 Cleaning

The TUFF-BLOC Self Retracting Lifeline may be cleaned by the end user periodically to increase service life. After cleaning, the product shall undergo the pre-use inspection.

Housing and Connectors - Clean the housing and connectors with a rag and warm water to remove dirt and grit. A mild detergent may be used to remove grease or oils from the product.

Cable - Wipe the cable with a damp cloth with mild detergent to remove grit, grease and debris. Once clean, dry the cable with a clean dry rag before allowing the cable to return to the housing.

**⚠ *Never submerge this product in water or allow the housing to be filled with water.***

**⚠ *Do not store this product when wet. Allow the product to dry and conduct a pre-use inspection prior to return the item to service.***

## 6 Inspection

**⚠ *Failure to properly inspect this product at the required intervals may result in the product malfunctioning, causing serious injury or death. Always inspect in accordance with this instruction.***

### 6.1 Before and After Use

The TUFF-BLOC Self Retracting Lifeline shall be inspected before and after each use by the user.

### 6.2 Competent Person

A competent person shall inspect the product at least every 12 months in accordance with this instruction.



### **6.3 Procedure**

6.3.1 Labels - inspect the labels are present and legible as per Figure 10 in this instruction. Inspect the serial number is legible, see Figure 8 for location.

6.3.2 Connector - inspect the body and gate of the connector for chips, cracks, discolouration, damage to the protective coating, bending or warping. Ensure the gate mechanism functions smoothly and when released automatically closes and locks.

6.3.3 Cable - withdraw the entire length of cable from the housing and inspect for broken wires or strands, kinks, bends, foreign material (dirt, grit, grease, weld spatter etc.). Inspect the termination contains 2 ferrules, the ferrules are crimped and secure. Allow the cable to retract back in to the housing. Ensure the cable returns to the housing without intervention.

6.3.4 Housing - inspect the housing is free of cracks, damage or deformation. Ensure all screws are present and not loose.

6.3.5 Handle - Check the web for damage, cuts, abrasion and contamination. Inspect the hooks are not bent, cracked, corroded or damaged. Ensure the latches open and close correctly.

6.3.6 Function - withdraw the cable from the housing and inspect it returns smoothly and completely. By holding the grip provided on the cable, pull the cable from the housing quickly and ensure the product locks. After locking, the cable should return to the housing as usual.

<b>INSPECTION RECORD</b>			
Supplier	SafetyLink Pty Ltd	54 Bonville Ave, Thornton, NSW, 2322, Australia	
Product Code		Date or Purchase	
Serial or Batch No.		Date of Manufacture	
Inspector		Date of First Use	
Date of Inspection		Date of Next Inspection	
<b>PROCEDURE</b>	<b>INSPECTION</b>	<b>USER</b>	<b>COMPETENT PERSON</b>
<b>6.3.1</b>	Inspect the labels are present and legible as per Figure 10	<input type="checkbox"/>	<input type="checkbox"/>
	Inspect the serial number is legible, see Figure 8	<input type="checkbox"/>	<input type="checkbox"/>
	Comments:		
<b>6.3.2</b>	Inspect the body and gate of the connector for chips, cracks, discolouration, damage to the protective coating, bending or warping.	<input type="checkbox"/>	<input type="checkbox"/>
	Ensure the gate mechanism functions smoothly and when released automatically closes and locks.	<input type="checkbox"/>	<input type="checkbox"/>
	Comments:		
<b>6.3.3</b>	Withdraw the entire length of cable from the housing and inspect for broken wires or strands, kinks, bends, foreign material (dirt, grit, grease, weld spatter etc.).	<input type="checkbox"/>	<input type="checkbox"/>
	Inspect the termination contains 2 ferrules, the ferrules are crimped and secure.	<input type="checkbox"/>	<input type="checkbox"/>
	Allow the cable to retract back in to the housing. Ensure the cable returns to the housing without intervention.	<input type="checkbox"/>	<input type="checkbox"/>
	Comments:		
<b>6.3.4</b>	Inspect the housing is free of cracks, damage or deformation.	<input type="checkbox"/>	<input type="checkbox"/>
	Ensure all screws are present and not loose.	<input type="checkbox"/>	<input type="checkbox"/>
	Comments:		
<b>6.3.5</b>	Check the web for damage, cuts, abrasion and contamination. Inspect the hooks are not bent, cracked, corroded or damaged	<input type="checkbox"/>	<input type="checkbox"/>
	Ensure the latches open and close correctly.	<input type="checkbox"/>	<input type="checkbox"/>
	Comments:		
<b>6.3.6</b>	Withdraw the cable from the housing and inspect it returns smoothly and completely.	<input type="checkbox"/>	<input type="checkbox"/>
	By holding the grip provided on the cable, pull the cable from the housing quickly and ensure the product locks. After locking, the cable should return to the housing as usual.	<input type="checkbox"/>	<input type="checkbox"/>
	Comments:		

# WARRANTIES

## EXTRACT: SAFETYLINK PTY LTD STANDARD TERMS AND CONDITIONS

1.1 To the extent permitted by law all implied conditions, warranties and undertakings are expressly excluded.

1.2 Except as provided in this clause the Company shall not be liable for any loss or damage, whether direct or indirect (including consequential losses or damage) arising out of any breach of contract by the Company or any negligence of the Company, its employees or agents.

1.3 Should the Company be liable for a breach of a guarantee, condition or warranty implied by the Australian Consumer Law (not being a guarantee, condition or warranty implied by sections 51, 52 and 53 of that Law) then its liability for a breach of any such condition or warranty express or implied shall be limited, at its option, to any one or more of the following.

A in case of Goods

- I the replacement of the Goods or the supply of equivalent Goods.
- II the repair of the goods,
- III the payment of the cost of replacing the Goods or acquiring equivalent Goods.
- IV the payment of the cost of having the Goods repaired. Provided that any such Goods are returned to the Company by the Purchaser at the Purchaser's expense.

B in the case of services

- I the supply of the services again,
- II the payment of the cost of having the services supplies again.

1.4 The Company is not liable for the costs of recovery of the Goods from the field, loss of use of the Goods, loss of time, inconvenience, incidental or consequential loss or damage, nor for any other loss or damage other than as stated above, whether ordinary or exemplary, caused either directly or indirectly by use of the Goods.

1.5 The Company warrants that at the time of shipment, Products manufactured by it will be free from defects in material and workmanship. In the absence of a modified written warranty, the Company agrees to making good any such defects by repairing the same or at the Company's option by replacement, for a period of (1) one year from the date of shipment. This limited warranty applies provided that:

- a defects have arising solely from faulty materials or workmanship;
- b the Products have not received maltreatment, inattention or interference;
- c the Products have been installed in accordance with the Company's Installation Handbooks using only products supplied by the Company;
- d accessories used with the Products are manufactured by or approved by the Company

- e the Products are maintained in accordance with Australian Standard 1891.4 (section 9).
- f you notify any claim under this warranty to SafetyLink in writing to the address below no later than 14 days after the event or occurrence concerning the produce giving rise to the claim and you pay all costs related to your claim.

This warranty does not apply to any defects or other malfunctions caused to the Goods by accident, neglect, vandalism, misuse, alteration, modification or unusual physical, environment or electrical stress.

Please note that the benefits to the purchaser (as a consumer) given by this warranty are in addition to your other rights and remedies under the Australian Consumer Law. Our goods come with guarantees that cannot be excluded under the Australian Consumer Law. You are entitled to a replacement or refund for a major failure and compensation for any other reasonably foreseeable loss or damage. You are also entitled to have the goods repaired or replaced if the goods fail to be of acceptable quality and the failure does not amount to a major failure.

1.6 If any goods are not manufactured by the Company, the guarantee of the manufacturer thereof shall be accepted by the Purchaser as the only express warranty given in respect of the goods.

1.7 Except as provided in this clause 11, all express and implied warranties, guarantees and conditions under statute or general law as the merchantability, description, quality, suitability or fitness of the Products for any purpose or as to design, assembly, installation, materials or workmanship or otherwise are hereby expressly excluded (to the extent to which they may be excluded by law).

**PLEASE SEE SAFETYLINK PTY LTD FULL STANDARD TERMS OF CONDITIONS OF SALE FOR FURTHER REFERENCE.**

# EU DECLARATION OF CONFORMITY

## TUFF-BLOC SELF RETRACTING LIFELINE



This declaration of conformity is issued under the sole responsibility of the manufacturer SafetyLink Pty Ltd of 54 Bonville Avenue, Thornton, NSW, 2322, Australia. The following items conform with the provisions of regulation (EU) 2016/425.

### **PART NUMBER:**

TUFF-BLOC006

TUFF-BLOC010

TUFF-BLOC015

TUFF-BLOC020

These Products are certified to EN360 : 2002

Notified body SATRA Technology Europe Limited NB2777 performed the EU type-examination Module B and issued the EU type-examination certificate STE0295314.

The PPE is subject to the conformity assessment procedure Module D under surveillance of the notified body SATRA Technology Europe Limited NB2777.

Signed By: Oscar Ratalino



03/2021

Head of Engineering

SafetyLink Pty Ltd



**SafetyLink®**

*Innovative  
Fall Protection*



SafetyLink Pty Ltd | ABN 83 081 777 371 | [www.safetylink.com](http://www.safetylink.com)

Head Office: 54 Bonville Ave, Thornton, 2322, NSW, Australia

+61 2 4964 1068 | 1300 789 545

Asia-Pacific/The Americas | [info@safetylink.com](mailto:info@safetylink.com)

Europe/Africa/Middle East | [europe.sales@safetylink.com](mailto:europe.sales@safetylink.com)

Northern Europe | [uk.sales@safetylink.com](mailto:uk.sales@safetylink.com)