



INSTALLATION INSTRUCTIONS ①

5908282 REV. H

LAD-SAF™ ②

Flexible Cable
Safety Systems



Fall Protection

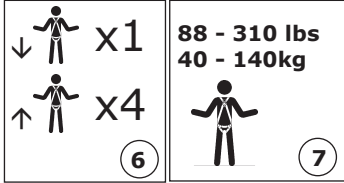

CE TYPE TEST	No. 2777 Satra Technology Europe Ltd Bracetown Business Park Clonee, Dublin D15 YN2P, Ireland ④
--------------	--

CE PRODUCTION QUALITY CONTROL	No. 0086 BSI Kitemark Court Davy Avenue Knowlhill Milton Keynes MK5 8PP United Kingdom ⑤
-------------------------------	---

③	
ISO 9001	ANSI Z359.16
CE	EN353-1:2014+A1:2017
	CSA Z259.2.5
OSHA	1926.1053, 1910.29

1

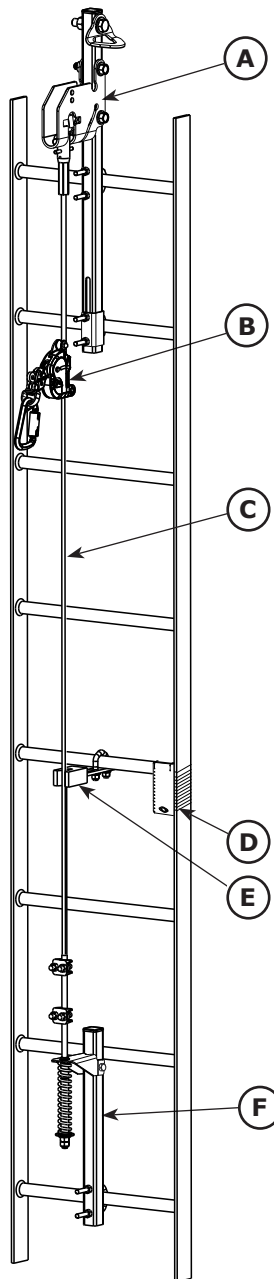

2

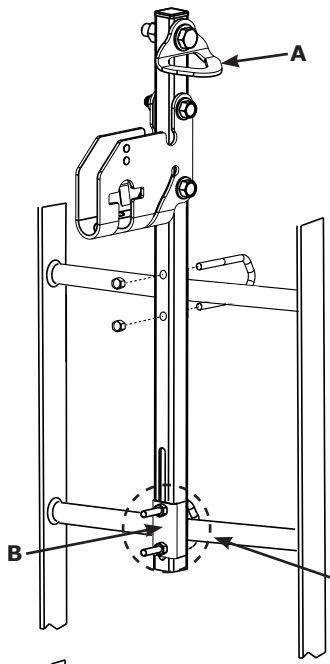

L1 #6116632

L2 #6116631

T	20 - 25 ft-lbs
	27 - 34 Nm

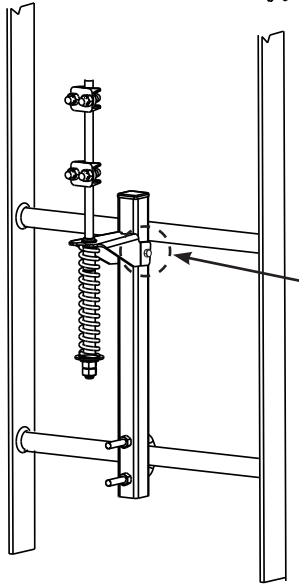

T	40 - 45 ft-lbs
	54 - 61 Nm

3

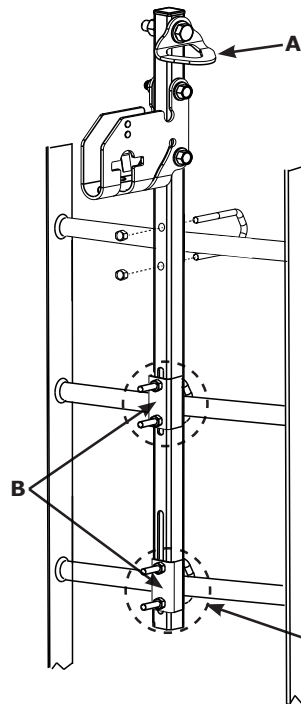

L3 #6116633

T	20 - 25 ft-lbs
	27 - 34 Nm

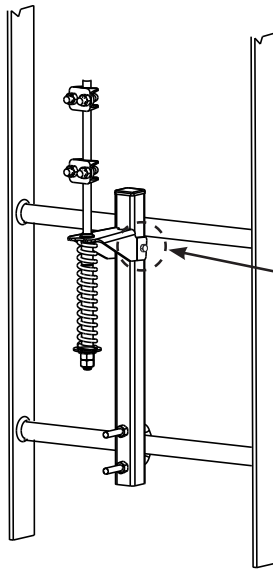

T	40 - 45 ft-lbs
	54 - 61 Nm

4

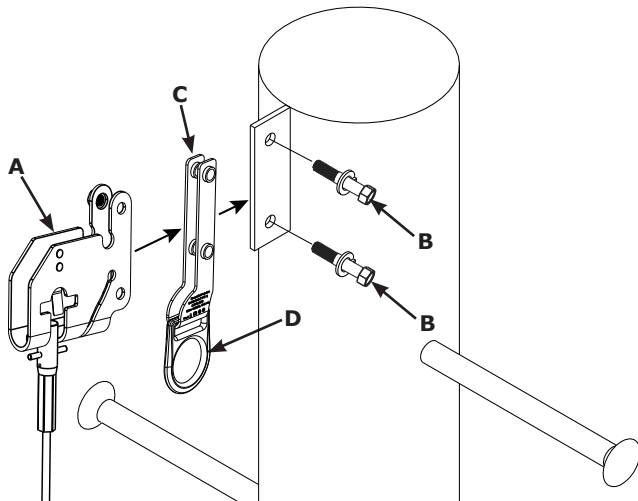

M1 #6116638

M2 #6116634

T	40 - 45 ft-lbs
	54 - 61 Nm

2

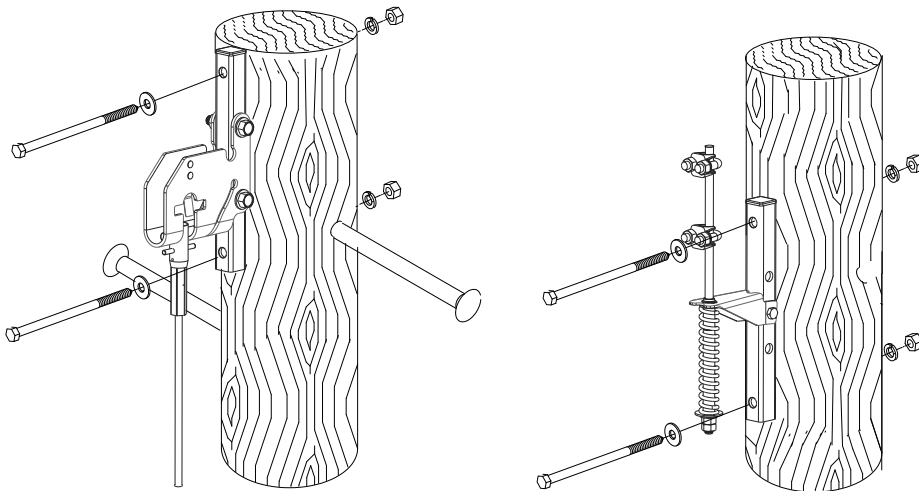
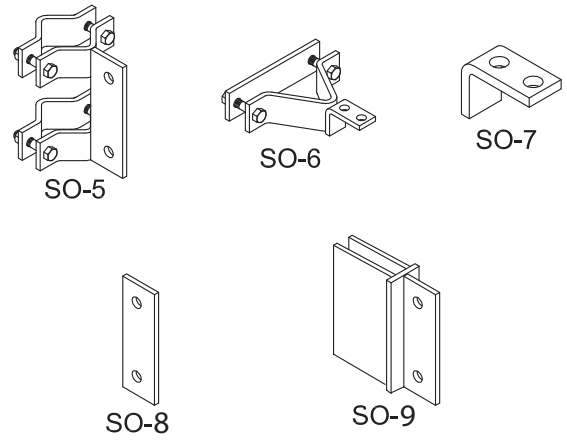
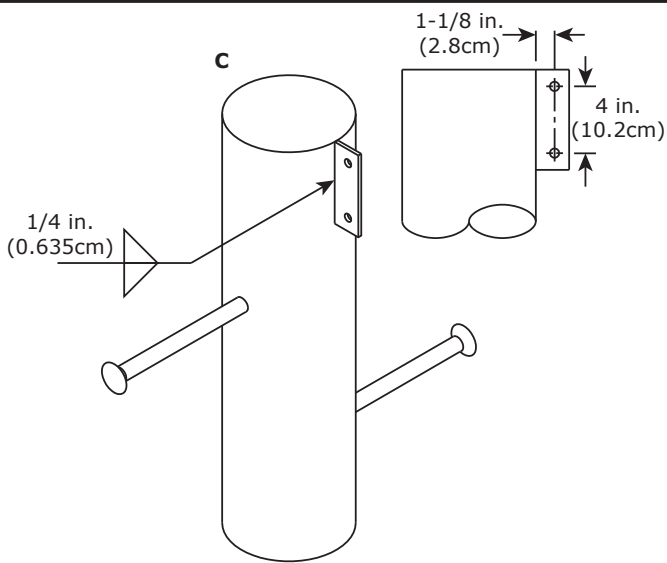
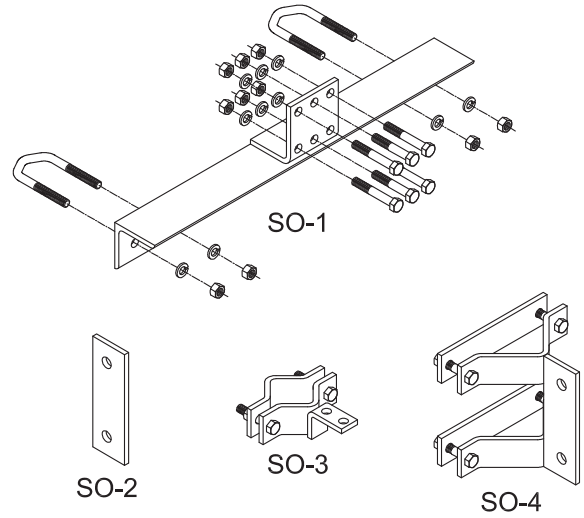
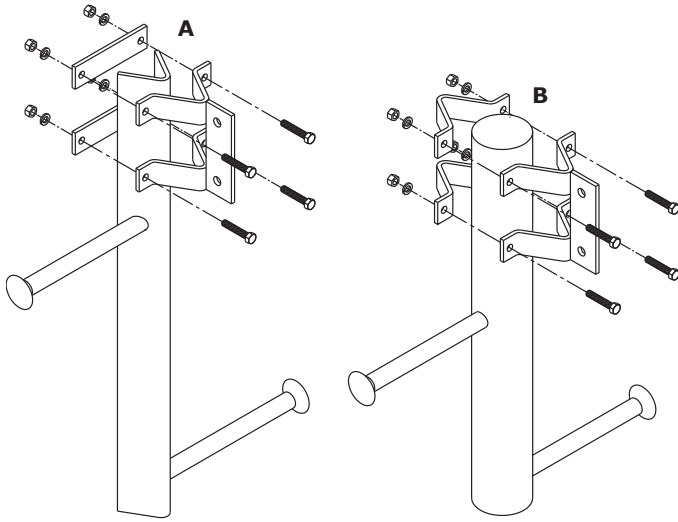

W1 #6116635

8

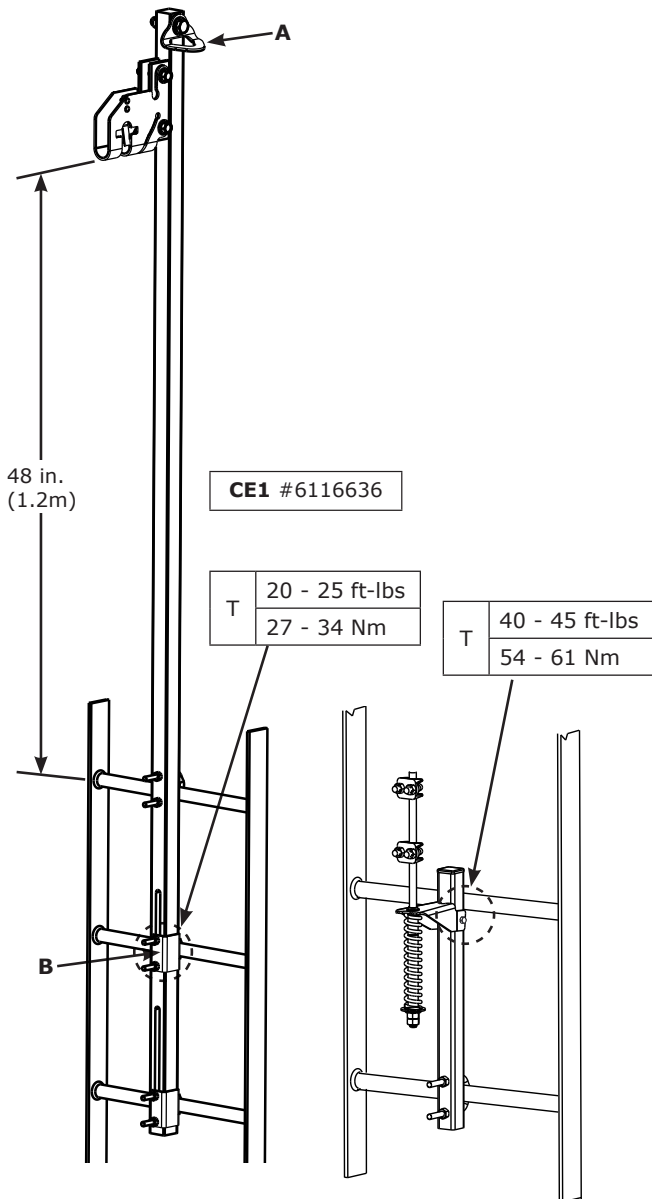

9

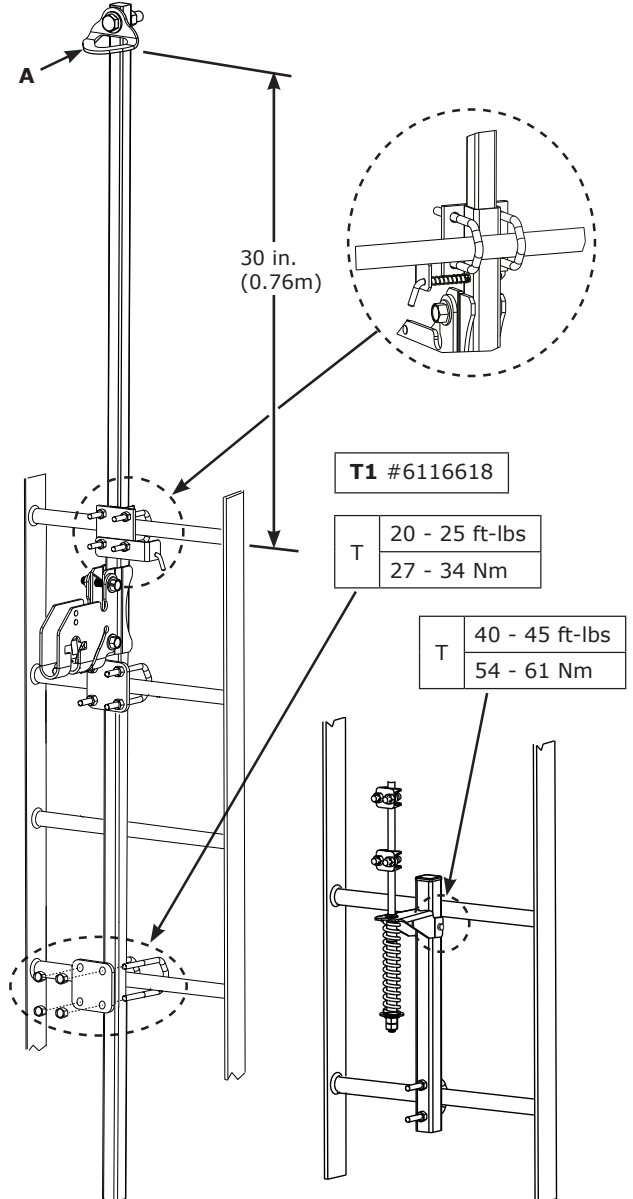

10

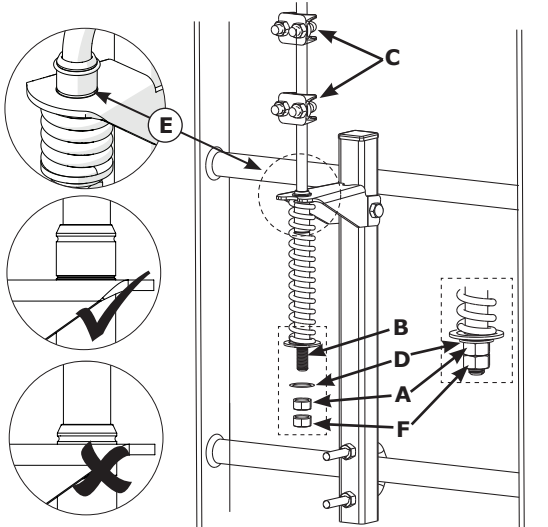

11

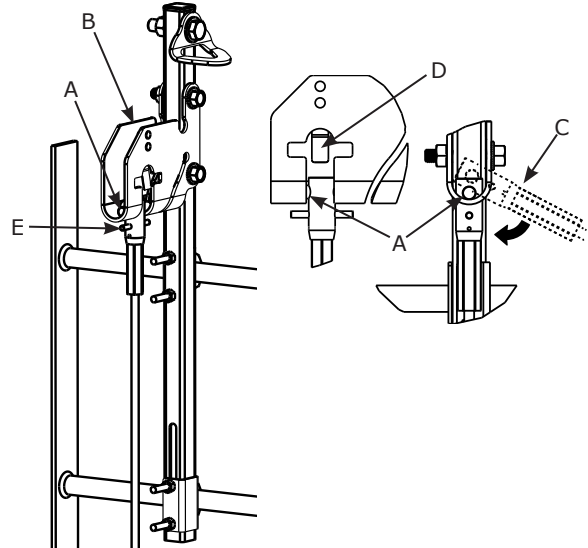

12

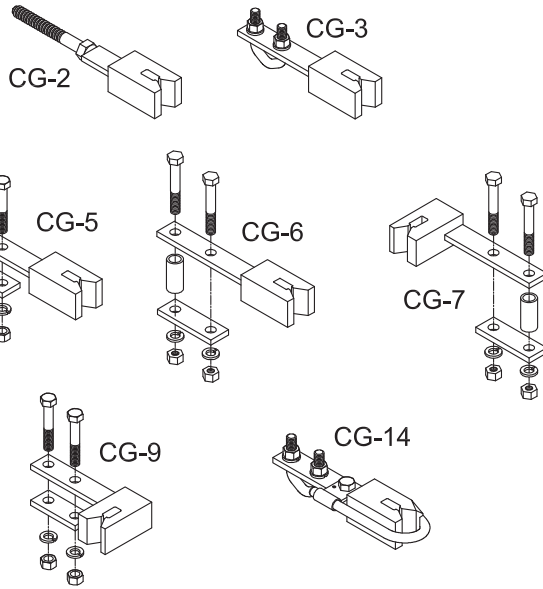
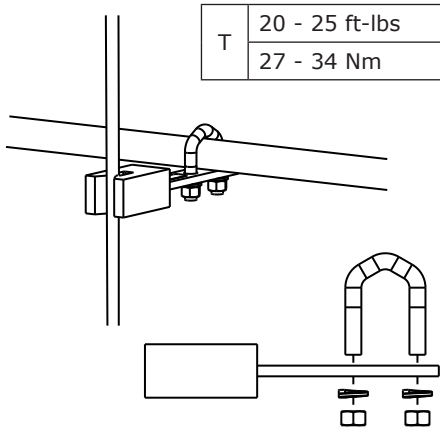

13

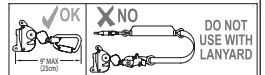
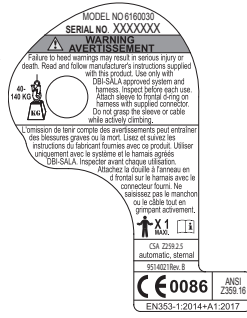
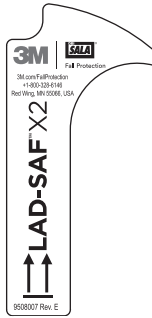
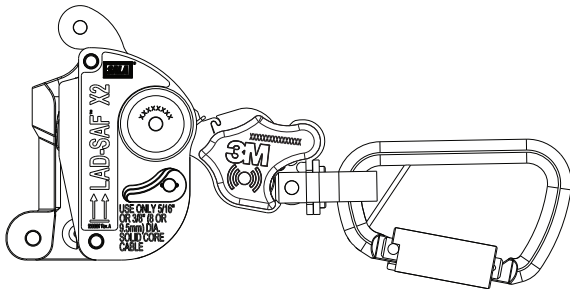

14

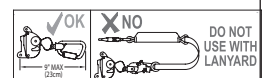
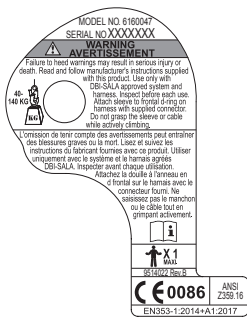
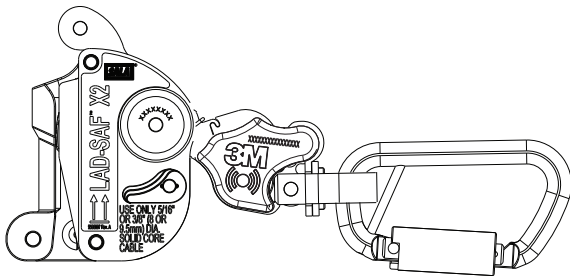

15

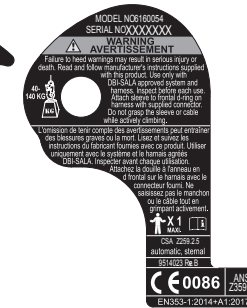
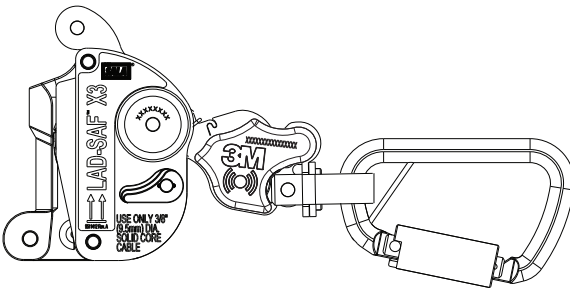

16

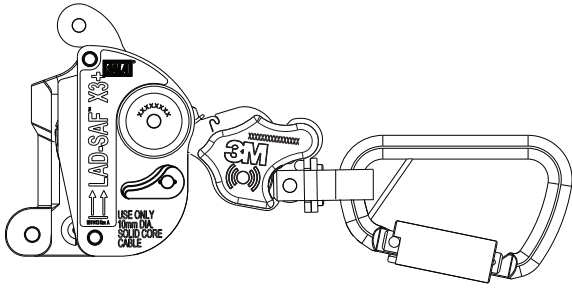

17

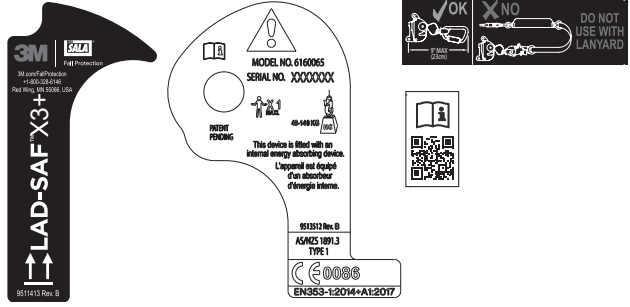
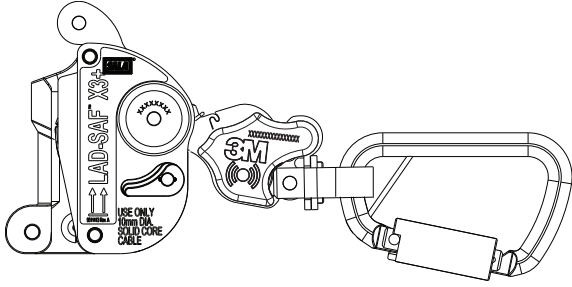

18

3M **LAD-SAF™** Fall Protection
 3M.com/FallProtection
 1-800-328-6146
 Red Wing, MN 55066, USA

1 2 3 4 5 6 7 8 9 10 11

11

3/8" (9.5mm) CABLE

3/8" (9.5mm) CABLE	1	2	3	4	5	6	7	8	9	10	11
1	✓	✓	✓	✓	✓	✓	✓	✓	✓	✓	✓
2	✓	✓	✓	✓	✓	✓	✓	✓	✓	✓	✓
3	✓	✓	✓	✓	✓	✓	✓	✓	✓	✓	✓
4	✓	✓	✓	✓	✓	✓	✓	✓	✓	✓	✓
5	✓	✓	✓	✓	✓	✓	✓	✓	✓	✓	✓
6	✓	✓	✓	✓	✓	✓	✓	✓	✓	✓	✓
7	✓	✓	✓	✓	✓	✓	✓	✓	✓	✓	✓
8	✓	✓	✓	✓	✓	✓	✓	✓	✓	✓	✓
9	✓	✓	✓	✓	✓	✓	✓	✓	✓	✓	✓
10	✓	✓	✓	✓	✓	✓	✓	✓	✓	✓	✓
11	✓	✓	✓	✓	✓	✓	✓	✓	✓	✓	✓

9513246 Rev. E

19

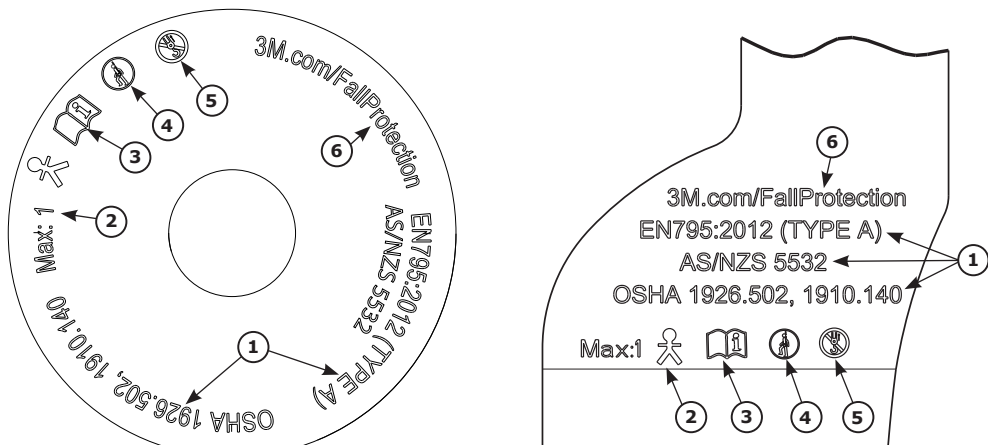

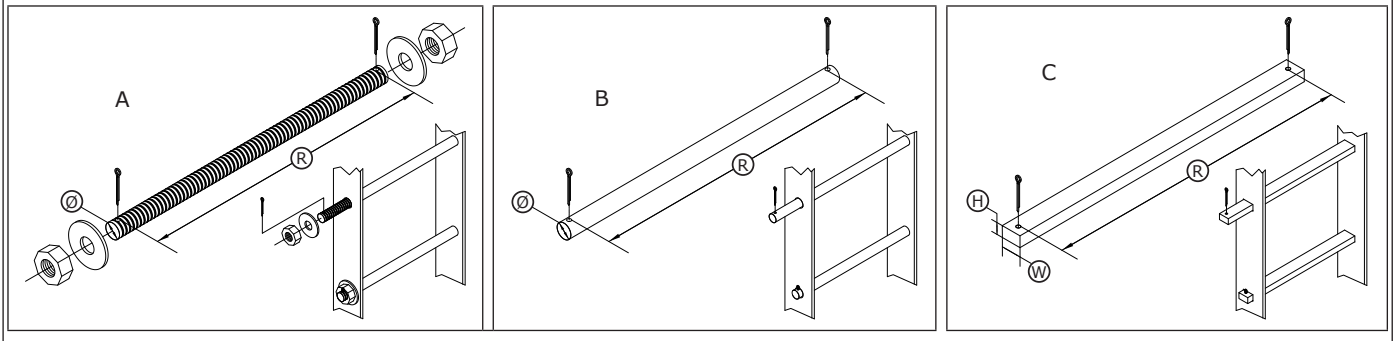

EN SAFETY INFORMATION

Please read, understand, and follow all safety information contained in these instructions prior to the use of this Vertical System. FAILURE TO DO SO COULD RESULT IN SERIOUS INJURY OR DEATH.

These instructions must be provided to the user of this equipment. Retain these instructions for future reference.

Intended Use:

This Vertical System is intended for use as part of a complete personal fall protection system.

Use in any other application including, but not limited to, material handling, recreational or sports related activities, or other activities not described in the Product Instructions, is not approved by 3M and could result in serious injury or death.

This device is only to be used by trained users in workplace applications.

WARNING

This Flexible Cable/Rigid Rail System is part of a personal fall protection system. It is expected that all users be fully trained in the safe installation and operation of their personal fall protection system. **Misuse of this device could result in serious injury or death.** For proper selection, operation, installation, maintenance, and service, refer to these Product Instructions and all manufacturer recommendations, see a supervisor, or contact 3M Technical Service.

- **To reduce the risks associated with working with a Flexible Cable/Rigid Rail System which, if not avoided, could result in serious injury or death:**
 - Inspect all components of the system before each use, at least annually, and after any fall event. Inspect in accordance with the Product Instructions.
 - If inspection reveals an unsafe or defective condition in a component of the system, remove the component from service and destroy it.
 - Any Flexible Cable/Rigid Rail System that has been subject to fall arrest or impact force must be immediately removed from service and all components must be inspected by a Competent Person prior to being used again.
 - Do not connect to the system while it is being installed.
 - Ensure the system is appropriately rated for the number of simultaneous users.
 - When unpacking the cable it may rapidly uncoil. Use proper safety procedures and appropriate personal protective equipment when unpacking cable.
 - Only use approved connectors to attach body harness to the system. Do not use any additional connecting devices.
 - Use only cable specified and approved in the Product Instructions.
 - Do not interfere with the locking action of the shuttle/sleeve device. Only manipulate the device to attach and detach from the system.
 - Always maintain three points of contact while climbing. Refer to the Product Instructions for further information on proper climbing technique.
 - Ensure that fall protection systems/subsystems assembled from components made by different manufacturers are compatible and meet the requirements of applicable standards, including the ANSI Z359 or other applicable fall protection codes, standards, or requirements. Always consult a Competent and/or Qualified Person before using these systems.
- **To reduce the risks associated with working at height which, if not avoided, could result in serious injury or death:**
 - Ensure your health and physical condition allow you to safely withstand all of the forces associated with working at height. Consult with your doctor if you have any questions regarding your ability to use this equipment.
 - Never exceed allowable capacity of your fall protection equipment.
 - Never exceed maximum free fall distance of your fall protection equipment.
 - Do not use any fall protection equipment that fails pre-use or other scheduled inspections, or if you have concerns about the use or suitability of the equipment for your application. Contact 3M Technical Services with any questions.
 - Some subsystem and component combinations may interfere with the operation of this equipment. Only use compatible connections. Consult 3M prior to using this equipment in combination with components or subsystems other than those described in the User Instructions.
 - Use extra precautions when working around moving machinery (e.g. top drive of oil rigs), electrical hazards, extreme temperatures, chemical hazards, explosive or toxic gases, sharp edges, or below overhead materials that could fall onto you or your fall protection equipment.
 - Use Arc Flash or Hot Works devices when working in high heat environments.
 - Avoid surfaces and objects that can damage the user or equipment.
 - Ensure there is adequate fall clearance when working at height.
 - Never modify or alter your fall protection equipment. Only 3M or parties authorized in writing by 3M may make repairs to the equipment.
 - Prior to use of fall protection equipment, ensure a rescue plan is in place which allows for prompt rescue if a fall incident occurs.
 - If a fall event occurs, immediately seek medical attention for the worker who has fallen.
 - Do not use a body belt for fall arrest applications. Use only a Full Body Harness.
 - Minimize swing falls by working as directly below the anchorage point as possible.
 - If training with this device, a secondary fall protection system must be utilized in a manner that does not expose the trainee to an unintended fall hazard.
 - Always wear appropriate personal protective equipment when installing, using, or inspecting the device/system.

EN Prior to installation and use of this equipment, record the product identification information from the ID label in the Installation Checklist at the back of this manual.

PRODUCT DESCRIPTION:

Figure 1 illustrates the Lad-Saf® Flexible Cable Safety System. Figures 2 through 19 illustrate components of the Lad-Saf® Flexible Cable Safety System. See Table 1 for system component descriptions. See Table 2 for system component specifications.

Table 1 – Component Descriptions	Item Number	Figure	Description																								
Systems L1 and L2	6116632 6116631	2	Used on standard rung attachments. Additional feature ("A" in Figure 2) serves as a single point anchor for a single user attachment. Minimum breaking strength is 3,600 lbs (16kN). Conforms to EN795:2012 Type A, OSHA 1926.502, 1910.140, AS/NZS 5532. L1 and L2 Systems will fit rung types and spacing listed below.																								
System L3	6116633	3	Used on standard rung attachments. Additional feature ("A" in Figure 3) serves as a single point anchor for a single user attachment. Minimum breaking strength is 3,600 lbs (16kN). Conforms to EN795:2012 Type A, OSHA 1926.502, 1910.140, AS/NZS 5532. L3 System will fit rung types and spacing listed below.																								
Systems M1 and M2	6116638 6116634	4	Used on standard monopoles or in combination with standoff supports. Mounting holes spaced 4" (101mm) on center. Additional feature ("C" in Figure 4) serves as a single point anchor for a single user attachment. Minimum breaking strength is 3,600 lbs (16kN). Conforms to EN795:2012 Type A, OSHA 1926.502, 1910.140, AS/NZS 5532.																								
System W1	6116635	7	Used on standard wood poles with 1/2" (12mm) fasteners.																								
System CE1	6116636	8	To extend the system up to 48" (1.2m) beyond a finishing platform. Additional feature ("A" in Figure 8) serves as a single point anchor for a single user attachment. Minimum breaking strength is 16kN (3,600 lbs). Conforms to EN795:2012 Type A, OSHA 1926.502, 1910.140, AS/NZS 5532. CE1 System will fit rung types and spacing listed below.																								
System T1 (ANSI/OSHA Certified Only)	6116618	9	Used on standard rung attachments. Telescoping tube will extend single point anchor to 30" (0.76m). Additional feature ("A" in Figure 9) serves as a single point anchor for a single user attachment. Minimum breaking strength is 3,600 lbs (16kN). Conforms to OSHA 1926.502 and 1910.140. T1 System will fit rung types and spacing listed below.																								
Tensioner		10	After groove pulls through plate, cable is in tension.																								
Cable Install		11	Confirm that the large pin is resting inside of the top plate.																								
Cable Guide		12	Used to guide the cable in vertical systems.																								
Standoff Bracket		5	Used in conjunction with the M1 and M2 system to provide an attachment for a safety system or cable guide.																								
Lad-Saf X2		13, 14	Used as a Sleeve in vertical systems. Allows the user to move freely up and down the system while maintaining attachment. Use only with supplied karabiner or snaphook.																								
Lad-Saf X3		15																									
Lad-Saf X3+		16, 17																									
System Tag		18	<p>System Tag Markings and RFID Tag</p> <table border="1"> <tr> <td>1</td> <td>Installation Date</td> <td>7</td> <td>Date Inspected</td> </tr> <tr> <td>2</td> <td>Installed By</td> <td>8</td> <td>System serial number</td> </tr> <tr> <td>3</td> <td>Anchorage Requirements</td> <td>9</td> <td>System warnings</td> </tr> <tr> <td>4</td> <td>Max Users Per System</td> <td>10</td> <td>Cable type and sleeve compatibility matrix along with standards certification.</td> </tr> <tr> <td>5</td> <td>System Length</td> <td>11</td> <td>RFID Tag</td> </tr> <tr> <td>6</td> <td>Date of Manufacture</td> <td></td> <td></td> </tr> </table>	1	Installation Date	7	Date Inspected	2	Installed By	8	System serial number	3	Anchorage Requirements	9	System warnings	4	Max Users Per System	10	Cable type and sleeve compatibility matrix along with standards certification.	5	System Length	11	RFID Tag	6	Date of Manufacture		
1	Installation Date	7	Date Inspected																								
2	Installed By	8	System serial number																								
3	Anchorage Requirements	9	System warnings																								
4	Max Users Per System	10	Cable type and sleeve compatibility matrix along with standards certification.																								
5	System Length	11	RFID Tag																								
6	Date of Manufacture																										
Single Point Anchor Warning		19	<p>Stamping on Washer, top of Systems L1, L2, L3, CE1 and T1. Stamping on Monopole Single Point Anchor Assembly ("C" in Figure 4) used with Systems M1 and M2.</p> <table border="1"> <tr> <td>1</td> <td>Standard to which Anchor conforms.</td> <td>4</td> <td>Used for fall arrest.</td> </tr> <tr> <td>2</td> <td>Maximum number of users.</td> <td>5</td> <td>Do not use for lifting.</td> </tr> <tr> <td>3</td> <td>Read user instruction.</td> <td>6</td> <td>Manufacturer internet site.</td> </tr> </table>	1	Standard to which Anchor conforms.	4	Used for fall arrest.	2	Maximum number of users.	5	Do not use for lifting.	3	Read user instruction.	6	Manufacturer internet site.												
1	Standard to which Anchor conforms.	4	Used for fall arrest.																								
2	Maximum number of users.	5	Do not use for lifting.																								
3	Read user instruction.	6	Manufacturer internet site.																								
Rung Supports		20	Used to provide additional support for rung types that are unable to withstand loading requirements as specified in Section 2.2.																								

L1, L2, L3, CE1 and T1 Systems will fit the following rung types and spacing:	
Spacing	9"-12.25" (200mm-310mm)
Cylindrical rung	0.5"-1.6" (13mm-40mm) diameter
Square rung	0.5"-1.6" (13mm-40mm)
Diamond rung	0.5"-1.6" (13mm-40mm) height
Angle Iron	0.5"-1.6" (13mm-40mm) leg height
Rectangular rung	0.5"-1.6" (13mm-40mm) height, 0.5"-1.9" (13mm-48mm) width

**Table 1 –
Component Descriptions**

	Item Number:		Figure	Description	Typical Application:	Structure Size:	Structure Type:
Standoff Bracket	SO-1	6100705	5	Flex Top/Btm Standoff, 2" OD 24.25" Pole Centers			
	SO-2	6100710		Flex Standoff, Pole, SS			
	SO-3	6100675		Flex Cable Guide Standoff, 2" OD Pole			
		6100677		Flex Cable Guide Standoff, 2-1/2" OD Pole			
		6100679		Flex Cable Guide Standoff, 3" OD Pole			
		6100680		Flex Cable Guide Standoff, 3-1/2" OD Pole			
		6100681		Flex Cable Guide Standoff, 4" OD Pole			
		6100682		Flex Cable Guide Standoff, 4-1/4" OD Pole			
	SO-4	6100636		Angle Iron Standoff 3", 90 Deg, Top & Bottom, Galv			
		6100642		Angle Iron Standoff 8", 90 Deg, Top & Bottom, Galv			
	SO-5	6100651		Flex Top/Btm Standoff, 2-3/8" OD Pole			
		6100652		Flex Top/Btm Standoff, 2-1/2" Dia Pole			
		6100654		Flex Top/Btm Standoff, 3" OD Pole			
	SO-6	6100621		Angle Iron Standoff 3", 90 Deg, Cable Guide, Galv			
		6100627		Angle Iron Standoff 6", 90 Deg, Cable Guide, Galv			
		6100629		Angle Iron Standoff 8", 90 Deg, Cable Guide, Galv			
6100635		Angle Iron Standoff 2", 90 Deg, Top & Bottom, SS					
SO-7	6100386	Flex Cable Guide Standoff, Steel					
SO-8	6100232	Flex Standoff, 5-10" Pole,					
SO-9	6100230	Flex Standoff					
Cable Guides	CG-2	6100140	12	Flex Cable Guide, SS	Wood pole	NA	NA
	CG-3	6100400		Flex Cable Guide Assy, Galv	Standard	< 1-1/8 in	Round/Square
	CG-3	6100401		Flex Cable Guide Assy, SS	LEB & Telescoping	<1-1/8 in	Round/Square
	CG-3	6100410		Flex Cable Guide, Galv	Standard	<1 in	Round/Square
	CG-5	6100427		Flex Cable Guide Assy, SS	Standard	1-5/8x1	Round/Square
	CG-3	6100440		Flex Cable Guide, SS	Standard	<1 in	Round/Square
	CG-3	6100450		Flex Cable Guide, SS	LEB & Telescoping	<1 in	Round/Square
	CG-6	6100454		Flex Cable Guide Assy, SS	Standard	1x3/4 in	Angle
	CG-5	6100457		Flex Cable Guide Assy, SS	Standard	<1 in	Round/Square
	CG-7	6100500		Flex Cable Guide, Galv, L	Monopole	5-3/4 in Long	NA
	CG-9	6100505		Flex Cable Guide Assy, SS, L	Monopole	5-3/4 in Long	NA
	CG-9	6100512		Flex Cable Guide, SS, L	Monopole	5-3/4 in Long	NA
	CG-9	6100513		Flex Cable Guide, SS, L	Standard	<1-5/8 in	Round/Square
	CG-9	6100515		Flex Cable Guide Assy, Galv, L	Monopole	5-3/4 in Long	NA
	CG-9	6100519		Flex Cable Guide, SS, L	Standard	<2-1/8 in	Round/Square
	CG-9	6100522		Flex Cable Guide Assy, Galv, L	Monopole	5-3/4 in Long	NA
	CG-7	6100527		Flex Cable Guide Assy, SS, L	Monopole	1x1 in	Angle
	CG-14	6100530		Flex Cable Guide Assy, Galv, Latch	Standard	<1 in	Round/Square
	CG-14	6100531		Flex Cable Guide, Galv, Latch	Standard	<1 in	Round/Square

Table 2 – Component Specifications				Standards	Figure	Capacity (lbs/kg)	Minimum User Weight (lbs/kg)	No. Users	Activation Force (lbs/kN)	Max deployment length (in/mm)	Minimum Breaking Strength (lbs/kN)	Weight (lbs/kg)	Operating temp range (°F/°C)	
Component	Item Number	Material	Part Code										Max	Min
System - L1*	6116632	304 Stainless Steel	L1	ANSI, AUS, CE, CSA, OSHA	2	310/140		2			3,600/16	20/9.1	140/60	-40/-40
System - L2*	6116631	Galvanised Steel	L2	ANSI, AUS, CE, CSA, OSHA	2	310/140		2			3,600/16	20/9.1	140/60	-40/-40
System - L3*	6116633	Galvanised Steel	L3	ANSI, AUS, CE, CSA, OSHA	3	310/140		4			4,560/20.27	24/10.9	140/60	-40/-40
System - M1*	6116638	304 Stainless Steel	M1	ANSI, AUS, CE, CSA, OSHA	4	310/140		4**			4,560/20.27	9/4.1	140/60	-40/-40
System - M2*	6116634	Galvanised Steel	M2	ANSI, AUS, CE, CSA, OSHA	4	310/140		4**			4,560/20.27	9/4.1	140/60	-40/-40
System - W1	6116635	Galvanised Steel	W1	ANSI, AUS, CE, CSA, OSHA	7	310/140		2			3,600/16	14/6.4	140/60	-40/-40
System - CE1*	6116636	Galvanised Steel	CE1	ANSI, AUS, CE, CSA, OSHA	8	310/140		2			3,600/16	46/21	140/60	-40/-40
System - T1*	6116618	Galvanised Steel	T1	ANSI, OSHA	9	310/140		4			4,560/20.27	40/18.2	140/60	-40/-40
Lad-Saf X2	6160030	Stainless Steel		ANSI, CE, CSA, OSHA	13	310/140	88/40	1	450/2	4.0/102	3,600/16	2.1/1	140/60	-40/-40
Lad-Saf X2	6160047	Stainless Steel		ANSI, CE, CSA, OSHA	14	310/140	88/40	1	450/2	4.0/102	3,600/16	2.1/1	140/60	-40/-40
Lad-Saf X3	6160054	Stainless Steel		ANSI, CE, CSA, OSHA	15	310/140	88/40	1	450/2	4.0/102	3,600/16	2.1/1	140/60	-40/-40
Lad-Saf X3+	6160052	Stainless Steel		AUS, CE	16	310/140	88/40	1	450/2	4.0/102	3,600/16	2.1/1	140/60	-40/-40
Lad-Saf X3+	6160065	Stainless Steel		AUS, CE	17	310/140	88/40	1	450/2	4.0/102	3,600/16	2.1/1	140/60	-40/-40
Cable - 3/8" (9.5mm) 1x7	6104XXX / CE 6134XXX(m)	Galvanised Steel									15,400/68.4	0.27/ft-0.41/m	140/60	-40/-40
Cable - 3/8" (9.5mm) 1x7	6105XXX / CE 6135XXX(m)	Stainless Steel									18,000/80	0.27/ft-0.41/m	140/60	-40/-40
Cable - 3/8" (9.5mm) 7x19	6106XXX / CE 6136XXX(m)	Galvanised Steel									14,400/64	0.27/ft-0.41/m	140/60	-40/-40
Cable - 3/8" (9.5mm) 7x19	6107XXX / CE 6137XXX(m)	Stainless Steel									12,000/53.3	0.27/ft-0.41/m	140/60	-40/-40

*System - Single Point Anchor minimum breaking strength 3,600 lbs (16kN).

** Number of users limited to 1 when used in conjunction with SO-4 & SO-5. See Figure 5.

References on cover		
①	Installation instructions	
②	Lad-Saf™ Flexible Cable Safety Systems	
③	Standards	
④	Number of notified body that performed CE test.	
⑤	Number of notified body checking the manufacture of this PPE.	
⑥	Number of users.	
⑦	User weight is 88 - 310 lbs (40 - 140kg) including tools, other equipment and clothing.	

Figure 1		
Ⓐ	Top Bracket	
Ⓑ	Sleeve	
Ⓒ	Cable	
Ⓓ	RFID Tag	
Ⓔ	Cable Guide	
Ⓕ	Bottom Bracket	

1.0 PRODUCT APPLICATION

- 1.1 PURPOSE:** The 3M DBI-SALA LAD-SAF™ Flexible Cable Safety System (Figure 1) is part of a personal fall protection system. When used in combination with the Lad-Saf™ Detachable Cable Sleeve (sold separately), the Lad-Saf™ Flexible Cable Safety System is designed to protect a worker in the event of a fall while climbing fixed ladders or similar climbing structures. LAD-SAF™ Flexible Cable Safety Systems are intended to be installed on fixed ladders or ladder like climbing surfaces that are part of a structure (e.g., mono poles [wood, steel, or concrete] buildings, manways, antenna structures and towers). The personal protection equipment (PPE) which is selected will form an essential part of the system. Always wear a full body harness with a sternal (chest) attachment point, in accordance with ANSI Z359.11 or with the relevant national standard. When climbing, the user of the system should wear a climbing helmet which conforms to the national standard.
- 1.2 LIMITATIONS:** LAD-SAF™ Flexible Cable Safety Systems are not intended to be installed on portable ladders. LAD-SAF™ Flexible Cable Safety Systems are designed for use on structures that are generally vertical. The safety system must not exceed a maximum angle of 15° from vertical. The following application limitations must be considered before installing the LAD-SAF™ Flexible Cable Safety System.
- A. STRUCTURE:** The structure to which the LAD-SAF™ Flexible Cable Safety System is installed must be capable of withstanding the loads applied by the system in the event of a fall (see Section 2.2).
 - B. SYSTEM CAPACITY:** The number of users allowed on the LAD-SAF™ Flexible Cable Safety System at one time varies depending on the type of system and installation. Generally, LAD-SAF™ Flexible Cable Safety System capacities range from one to four users. See Table 2 for more information on capacity limitations. LAD-SAF™ Flexible Cable Safety System capacities are based on a maximum user weight of 310 lbs (140kg), including tools and clothing.
 - C. ENVIRONMENTAL HAZARDS:** Use of the LAD-SAF™ Flexible Cable Safety System in areas with environmental hazards may require that additional precautions be taken to reduce the possibility of injury to the user or damage to the equipment. (e.g., high heat caused by welding or metal cutting, caustic chemicals, seawater, high voltage power lines, explosive or toxic gases, moving machinery, sharp edges).
- 1.3 SUPERVISION:** Installation of the LAD-SAF™ Flexible Cable Safety System must be supervised by a Qualified Person¹.
- 1.4 TRAINING:** The LAD-SAF™ Flexible Cable Safety System must be installed by persons trained in its correct application. This manual is to be used as part of an employee training program as required by OSHA. It is the responsibility of the installers of this equipment to ensure they are familiar with these instructions, trained in the correct care of this equipment.
- 1.5** Refer to applicable local, and national requirements governing this equipment for more information on vertical safety systems and associated components, including OSHA 1910.140, OSHA 1910.29, OSHA 1926.1053 and OSHA 1926.502.

2.0 SYSTEM CONSIDERATIONS

- 2.1 COMPATIBILITY OF COMPONENTS AND SUBSYSTEMS:** This equipment is designed for use with 3M Fall Protection approved components and subsystems. The use of non-approved components and subsystems (e.g., harnesses, lanyards, sleeves, etc.) may jeopardize compatibility of equipment, and could affect the safety and reliability of the complete system. If you have questions on the installation or suitability of this equipment for your application, contact 3M Fall Protection.

COMPATIBILITY WITH CLIMB ASSIST SYSTEMS: 3M Fall Protection LAD-SAF™ Flexible Cable Safety Systems, including 3M Fall Protection LAD-SAF™ Detachable Cable Sleeves, are designed for use with 3M Fall Protection approved climb assist systems. The use of any other type of climb assist system may be incompatible with the LAD-SAF™ Flexible Cable Safety System and LAD-SAF™ Detachable Cable Sleeves, and could create a serious safety hazard for the user. Do not use non-3M Fall Protection climb assist systems without first consulting a competent person and/or a qualified person at your worksite for approval. If you have additional questions about compatibility, please contact 3M Technical Services.

☑ANSI Z359.1-2007 Safety Requirements for Personal Fall Arrest Systems, Subsystems and Components, requires a competent person and/or a qualified person to "ensure that systems assembled from components and subsystems made by different manufacturers meet the requirements of this standard."

1 Qualified Person: A person with a recognized degree of professional certificate and with extensive knowledge, training, and experience in the fall protection and rescue field who is capable of designing, analyzing, evaluating, and specifying fall protections and rescue systems to the extent required by OSHA and other applicable standards.

2.2 LOAD REQUIREMENTS FOR STRUCTURE: The climbing structure to which the LAD-SAF™ system is installed must be capable of supporting the total loading imposed by the system.

A. STATIC LOADING: The static loads imposed onto the system include the weight of the top bracket, weight of the cable per length of system and a safety factor (SF). The following is an example for determining the static loading imposed on the system for a 100 ft (30 m) system:

- i. L3 top bracket weight = 24 lbs (10.9 kg)
- ii. 100 ft (30m) of 3/8" (9.5mm) 1x7 Galvanized cable weight = 27 lbs (12.3 kg)
- iii. **TOTAL STATIC LOADING:** (24 lbs + 27 lbs) x 1.2SF = 61 lbs
(10.9 kg + 12.3 kg) x 1.2SF x 9.81 m/s² = 0.27 kN

B. DYNAMIC LOADING: The following are the dynamic loads imposed onto the system per user:

- i. One user: 2,700 lbs (12 kN)
- ii. Two user: 3,320 lbs (14.76 kN)
- iii. Three user: 3,940 lbs (17.51 kN)
- iv. Four user: 4,560 lbs (20.27 kN)

C. TOTAL LOADING: The total load imposed onto the structure must take into account the static and dynamic loading given above for the length and type of system. Below is an example in determining total loading imposed onto the structure:

- i. Static loading for a 100 ft (30 m) system: 61 lbs (0.27 kN)
- ii. Dynamic loading for a two-user system: 3,320 lbs (14.76 kN)
- iii. **Total loading = 3,381 lbs (15 kN)**

The following Systems allow up to two users on the system at one time (see Table 2):

Systems L1, L2, W1 and CE1.

The following Systems allow up to four users on the system at one time (see Table 2):

Systems L3, M1, M2 and T1.

For structures that require a continuous length of vertical lifeline over 500 ft (151m), 3M recommends the use of the following:

6116633 (4 users) – over 500 ft (151m) and up to 800 ft (242m).

6116633 (rated to 3 users) – over 800 ft (242m) and up to 2000 ft (606m).

The system can be rated to 2 users to lower the load imposed onto the attachment structure.

Other installation requirements may limit the number of users allowed on a system. See section 3.0.

Bottom Bracket Assembly: The bottom bracket connection must be capable of supporting a system pretension load of 350 lbs (1.6 kN) in the direction of loading.

For calculation purposes, the required bracket load may be assumed to be distributed evenly between the number of rung attachments.

3.0 SYSTEM INSTALLATION

3.1 LAD-SAF™ systems are designed for easy installation onto a variety of structures. To begin the installation you need to know the model numbers of the system, cable guides, standoffs and type of cable (galvanized or stainless steel). Figures 2 through 12 identify most models. Some brackets are designed to be installed using stand-off supports which go between the bracket and structure. You need to know model numbers of stand-off supports if included with your system. See Table 1 for model numbers of most stand-off supports. Follow the instructions for the models included in your system. Generally, the LAD-SAF™ system is installed from the top of the structure down. The basic procedure is:

- Step 1.** Install the top bracket
- Step 2.** Connect the cable to the top bracket
- Step 3.** Install the cable guides
- Step 4.** Install the bottom bracket assembly
- Step 5.** Tension the cable
- Step 6.** Inspect the installation

Planning the installation can minimize the amount of time on the structure and improve safety.

- Use proper safety procedures when installing LAD-SAF™ systems.**
- Wear personal protective equipment, including safety glasses and steel-toed shoes.**
- Use personal fall arrest or restraint systems when exposed to a fall hazard while installing LAD-SAF™ systems.**
- Do not connect to the LAD-SAF™ system being installed.**
- Do not connect to a partially installed LAD-SAF™ system.**
- Use caution when installing LAD-SAF™ systems near electrical power lines. LAD-SAF™ cables are conductive.**
- For installation of stainless steel systems, 3M recommends using a general purpose thread lubricant on all fasteners to prevent galling.**

3.2 WELDING RECOMMENDATIONS: Some installations require welding brackets to the structure. DBI-SALA recommends that welding be completed by a certified professional welder in accordance with applicable national welding codes or standards. Base and filler materials must be compatible with galvanized or stainless steel, depending on the materials of your system. Protect finished welds from corrosion with coating or paint.

3.3 RUNG SUPPORT: Rung supports can be used to reinforce hollow rungs to reduce crushing or collapsing of the rung due to tightening of the Safety System Clamps, and to generally strengthen the rung. The Rung Support must have sufficient length extending on either side of the Side Rails to install Rung Support fasteners. Install rung support at each LAD-SAF™ component connection point. The structure must be evaluated by a qualified person to determine if the load requirements for the system are met.

Rung Supports are available in various shapes and lengths. For best results, select a Rung Support size that will fit closely with the inside dimensions of the rung. See Figure 20 for examples of rung supports.

A, Figure 20	Model	Ø	R	Install at each point indicated below: 1. Slide the Rung Support through the open rung. 2. Slide Washers over each end of the Rung Support and secure with Nuts. Tighten Nuts until Washer's are flush against the Rail. 3. Insert Cotter Pins through the holes in each end of the Rung Support. Cotter Pins should inserted from the top of the Rung Support to prevent them from dropping out of the holes. 4. Separate and bend the Cotter Pin Legs to ensure Cotter Pins stay in the holes and the Rung Supports can not slide out of the Rung.
	6100187	1 in (2.5 cm)	22 in (56 cm)	
	6100188	1 in (2.5 cm)	26 in (66 cm)	
	6100189	1 in (2.5 cm)	30 in (76 cm)	
	Materials	Aluminum Bar, Stainless Steel Fasteners		

B, Figure 20	Model	Ø	R	Install at each point indicated below: 1. Slide the Rung Support through the open rung. 2. Insert Cotter Pins through the holes in each end of the Rung Support. Cotter Pins should inserted from the top of the Rung Support to prevent them from dropping out of the holes. 3. Separate and bend the Cotter Pin Legs to ensure Cotter Pins stay in the holes and the Rung Supports can not slide out of the Rung.
	6100151	1 in (2.5 cm)	17 in (43 cm)	
	Materials	Aluminum Bar, Stainless Steel Fasteners		

C, Figure 20	Model	H	W	R	Install at each point indicated below: 1. Slide the Rung Support through the open rung. 2. Insert Cotter Pins through the holes in each end of the Rung Support. Cotter Pins should inserted from the top of the Rung Support to prevent them from dropping out of the holes. 3. Separate and bend the Cotter Pin Legs to ensure Cotter Pins stay in the holes and the Rung Supports can not slide out of the Rung.
	6100186	.63 in (1.6 cm)	1 in (2.5 cm)	19 in (48 cm)	
	Materials	Aluminum Bar, Stainless Steel Fasteners			

3.4 TOP BRACKET INSTALLATION: Before installing the top bracket it is recommended that the climbing structure be evaluated by a qualified person to determine if the load requirements for the system are satisfied. The top bracket should be positioned to allow users safe access when connecting or disconnecting from the system. The top bracket is typically mounted in the center of the climbing surface for ease of climbing, but may be located towards the side if required.

A. INSTALLATION OF L1 AND L2 SYSTEMS:

See Figure 2 for a typical installation of the L1 and L2 Systems. The top bracket should be positioned to allow users safe access when connecting or disconnecting from the system. Do not substitute other fasteners.

Installation procedure:

- 1. Top Bracket:** Slide rung clamps (B) over tube and install fasteners as shown. Torque fasteners as specified.
- 2. Bottom Bracket:** Install fasteners as shown. Torque fasteners as specified.

B. INSTALLATION OF L3 SYSTEM:

See Figure 3 for a typical installation of the L3 System. The top bracket should be positioned to allow users safe access when connecting or disconnecting from the system. Do not substitute other fasteners.

Installation procedure:

- 1. Top Bracket:** Slide rung clamps (B) over tube and install fasteners as shown. Torque fasteners as specified.
- 2. Bottom Bracket:** Install fasteners as shown. Torque fasteners as specified.

C. INSTALLATION OF M1 AND M2 SYSTEMS:

See Figure 4 for a typical installation of the M1 and M2 System onto a monopole. The top bracket should be positioned to allow users safe access when connecting or disconnecting from the system. The top brackets are to be connected to the structure with a 3M DBI-SALA standoff or customer supplied stand-off support. Stand-off supports must support the loads specified in section 2.2, and must be compatible with the LAD-SAF™ system.

Angle Leg and Round Leg Stand-off Installation:

See Figure 5 for the installation of the angle (A) and round leg (B) stand-off supports. Install stand-off supports using the hardware provided. Do not substitute other fasteners. Torque 3/8-inch fasteners to 20-25 ft-lbs (27-34 N-m). Install the top bracket to the stand-off support using the 1/2-inch fasteners provided. Torque 1/2-inch fasteners to 40-45 ft-lbs (54-61 N-m).

Weld-on Stand-off Installation:

Install the stand-off support (C) as shown in Figure 5. See section 3.2 for welding recommendations. The stand-off must be perpendicular to the pole surface and in-line with the carrier cable.

Installations that use the angle leg or round leg stand-off support brackets are limited to one user on the system at a time.

M1 and M2 System Installation:

See Figure 4. Installation procedure:

- 1. Top Bracket:** Install top plate (A), hardware (B) and Single Point Anchor assembly (C) as shown in Figure 4. Slide the D-Ring (D) over the assembly (C) before installing. Torque fasteners as specified.
- 2. Bottom Bracket:** Install bolt, spacers and fasteners as shown. Torque fasteners as specified.

D. INSTALLATION OF W1 SYSTEM:

See Figure 7 for a typical installation of the W1 System on a wooden pole. The top bracket should be positioned to allow users safe access when connecting or disconnecting from the system. Use 1/2-inch fasteners (not provided) to attach the top bracket to the pole. Fasteners should extend through the pole when possible. 3M DBI-SALA recommends using lock washers, double nuts, or other methods to ensure fasteners will not loosen.

E. INSTALLATION OF CE1 SYSTEM:

See Figure 8 for a typical installation of the CE1 System. The top bracket should be positioned to allow users safe access when connecting or disconnecting from the system.

Installation procedure:

1. **Top Bracket:** Slide rung clamps (B) over tube and install fasteners as shown. Torque fasteners as specified.
2. **Bottom Bracket:** Install fasteners as shown. Torque fasteners as specified.

F. INSTALLATION OF T1 SYSTEM:

See Figure 9 for a typical installation of the T1 System. The top bracket should be positioned to allow users safe access when connecting or disconnecting from the system. Typical applications include access ladders into manholes or under trap doors. Do not substitute other fasteners.

Installation procedure:

1. **Top Bracket:** Install clamp plates and fasteners as shown. Torque fasteners as specified.
2. **Bottom Bracket:** Install fasteners as shown. Torque fasteners as specified.

3.5 INSTALLATION OF CARRIER CABLE ASSEMBLY TO TOP BRACKET:

A. INSTALLATION OF CARRIER CABLE ASSEMBLY:

1. Lay the carrier cable assembly out on the ground in a clean area by rolling the coil. Do not pull cable from center of coil. For some installations it may be easier to lower the carrier cable from the top connection level down to the bottom bracket. If so, carefully lower the cable by unspooling without twisting the cable at the top connection. Do not drop the cable to the lower level.

Carrier cable is very stiff and may spring out of coil unexpectedly. Use proper safety procedures when unrolling cable. Use appropriate safety gear, including gloves and safety glasses, when unrolling cable.

Inspect the cable for shipping damage before proceeding. Do not install damaged cable.

2. See Figure 11 for installation of the carrier cable into the top bracket. Ensure the end of cable is free of kinks and unraveled strands.

Installation procedure: Insert lug end (C) of carrier cable assembly into the side of the top plate (B) profile at an approximate angle of 45 degrees while pressing against spring gate (D). The small pin (E) and spring gate (D) are designed to prevent the lug/cable assembly from inadvertently disconnecting from the top plate (B). Make certain that only the large pin (A) rests inside the top plate (B).

3.6 INSTALLATION OF CABLE GUIDES, ALL MODELS:

Cable guides protect the carrier cable from chafing against the structure and to prevent the climber from excessively deflecting the cable from side to side. Cable guides should be positioned at approximately 20-40 ft (6-12m) along the carrier cable between the top and bottom brackets, and at any point along the system where the cable may abrade against the structure. Cable guides should be staggered along the system to reduce harmonic effects of the wind, such as at 23 (7.01), 25 (7.61), and 27 (8.23) feet (m) intervals. For high wind areas "L" shaped cable guides may be used. The "L" shaped cable guides should be alternated with opening on the left, then right, etc. up the structure Latching cable guides are also available.

Direct Connection to Structure:

See Figure 12 for a typical installation of a cable guide. Some cable guides utilize rung spacers and clamp plates while others do not (see Figure 12). Install the cable guide using the hardware provided. Do not substitute other fasteners. Torque fasteners to 20-25 ft-lbs (27-34 N-m).

3.7 TENSIONING THE SYSTEM:

Depending on the length of the system, and the environment in which the system is installed, it may be necessary to periodically re-tension the system. Extreme temperature ranges and very long systems will likely require periodic re-tensioning.

Carrier Cable Tension Adjustment:

1. See Figure 10. Thread tensioning nut (A) onto end of tension rod (B) so that 3-5 threads are exposed below the nut. Insert cable into saddle clamps (C). Lift up on tensioner assembly until tensioning nut bottoms out on bottom washer (D). Tighten saddle clamp nuts and torque to 35 ft-lbs (47.5 N-m). Tighten tensioning nut until groove (E) is exposed above top bracket. Tighten jam nut (F) against tensioning nut. Cut off excess cable just below the lower saddle clip.

4.0 IDENTIFICATION AND INSPECTION AFTER SYSTEM INSTALLATION:

- A. Install the installation and service label onto the structure in a prominent location. Use the steel wire provided with the label to attach it to the structure. Before installing the label, mark the following:

- Installation Date
- Installed By
- Maximum Users Per System
- System Length

Use a metal letter stamp to mark the label. Record the system identification information in the *Installation Checklist* at the end of this manual.

**U.S. PRODUCT WARRANTY, LIMITED REMEDY
AND LIMITATION OF LIABILITY**

WARRANTY: THE FOLLOWING IS MADE IN LIEU OF ALL WARRANTIES OR CONDITIONS, EXPRESS OR IMPLIED, INCLUDING THE IMPLIED WARRANTIES OR CONDITIONS OF MERCHANTABILITY OR FITNESS FOR A PARTICULAR PURPOSE.

Unless otherwise provided by applicable law, 3M fall protection products are warranted against factory defects in workmanship and materials for a period of one year from the date of installation or first use by the original owner.

LIMITED REMEDY: Upon written notice to 3M, 3M will repair or replace any product determined by 3M to have a factory defect in workmanship or materials. 3M reserves the right to require product be returned to its facility for evaluation of warranty claims. This warranty does not cover product damage due to wear, abuse, misuse, damage in transit, failure to maintain the product or other damage beyond 3M's control. 3M will be the sole judge of product condition and warranty options.

This warranty applies only to the original purchaser and is the only warranty applicable to 3M's fall protection products. Please contact 3M's customer service department at 800-328-6146 or via email at 3MFallProtection@mmm.com for assistance.

LIMITATION OF LIABILITY: TO THE EXTENT PERMITTED BY APPLICABLE LAW, 3M IS NOT LIABLE FOR ANY INDIRECT, INCIDENTAL, SPECIAL OR CONSEQUENTIAL DAMAGES INCLUDING, BUT NOT LIMITED TO LOSS OF PROFITS, IN ANY WAY RELATED TO THE PRODUCTS REGARDLESS OF THE LEGAL THEORY ASSERTED.



Fall Protection

Distributed by Engineered Fall Protection
Sales@EngineeredFallProtection.com
www.EngineeredFallProtection.com
Tel: (314) 492-4422



EU DECLARATION OF CONFORMITY:
3M.com/FallProtection/DOC