



arachnipod
Total Edge Management System



FERNO[®]

Users' Manual

Version 7.0 / August 2020



Read this Manual and Retain for future reference

Ferno Customer Service

For ordering, product assistance or general information:

AUSTRALIA

Telephone (Toll-free)	1800 804 647
Telephone	(07) 3881 4999
Fax	(07) 3881 1125
Email	info@ferno.com.au
Internet	www.ferno.com.au

ALL OTHER LOCATIONS

For assistance or information, please contact your Ferno distributor. If you do not have a Ferno distributor, please contact Ferno Customer Service:

Ferno Australia, 11 Johnstone Road,
Brendale, Queensland 4500, Australia

Telephone	Country Code +61 7 3881 4999
Fax	Country Code +61 7 3881 1125
Email	info@ferno.com.au

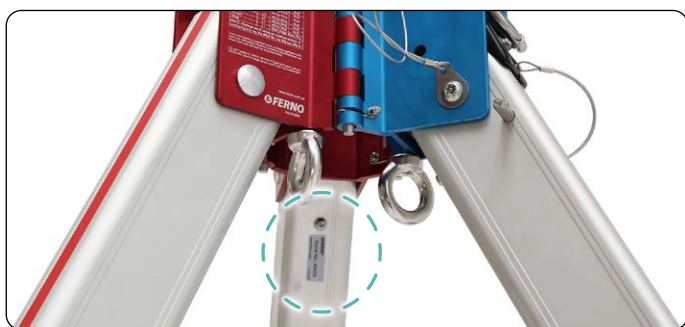

Arachnipod serial number(s) located at head end of Legs

Disclaimer

This manual contains general instructions for the use, operation and care of this product. The instructions are not all-inclusive. Safe and proper use of this product is solely at the discretion of the user. Safety information is included as a service to the user. All other safety measures taken by the user should be within and under consideration of applicable regulations and local protocol. Training on the proper use of this product must be provided before using this product in an actual situation.

Retain this manual for future reference. Include it with the product in the event of transfer to new users. Additional free copies are available upon request from Customer Service.

Proprietary Notice

The information disclosed in this manual is the property of Ferno Australia (herein referred to as Ferno). Ferno reserves all intellectual property rights, proprietary design rights, manufacturing rights, reproduction use rights, and sales use rights thereto, and to any article disclosed therein except to the extent those rights are expressly granted to others or where not applicable to vendor proprietary parts.

Limited Warranty Statement

Ferno products are warranted to be free from defects in material and workmanship for a period of one year, except as follows:

- External finishes (gelcoat, paint, powdercoat, decals, etc.) are warranted for 90 days.
- Soft goods (webbing, vinyl, fabric, foam, etc.) are warranted for 90 days.

Ferno repairs are warranted for 90 days from the date of repair.

This limited warranty applies only when you use and care for the product as described in the instructions provided with the product. Improper use and care may void this warranty. The warranty period begins the day the product is shipped from Ferno or the day you receive it if you have proof of the delivery date. Shipping charges are not covered by this limited warranty. Ferno is not liable for shipping damages or damages sustained through using the product, nor does Ferno assume any liability for products manufactured by others.

Limitation of Liability

If a product is proven defective, Ferno will repair or replace it, or, at our option, refund the item's purchase price. In no event is Ferno liable for more than the selling price of the product. The purchaser accepts these terms in lieu of all damages.

Except for the limited warranty above, Ferno makes no other warranties, either expressed or implied. Ferno makes no implied warranties of merchantability and fitness for a particular purpose for its own product or for the products of others. In no event will Ferno be liable for any indirect or consequential damages sustained in connection with the delivery, use, or performance of its products.

CE Compliance Information

CE Certifying Organisation

BSI Group The Netherlands B.V. (NB 2797)
Say Building, John M Keynesplein 9
1066 EP, Amsterdam, Netherlands

Certified in 3 & 4 leg configurations to CEN/TS 16415:2013 Type B for maximum 2 persons and
EN 795:2012 Type B for single person use.



Ferno Australia Pty Ltd
11 Johnstone Road
Brendale, QLD 4500, Australia
Tel: +61 7 3881 4999



Ferno-Washington Italia S.r.l.
via B. Zallone, n. 26, 40066
Pieve di Cento, Bologna, Italy
+39.051.6860028 234-3468-01



USERS' MANUALS

To request additional free users' manuals, contact Ferno Customer Relations, your Ferno distributor, or www.ferno.com.au

CONTENTS

Ferno Customer Service	2
1 - SAFETY INFORMATION	4
1.1 Warning	5
1.2 Notice	5
1.3 Tip	5
1.4 Product Lifespan Statement	5
1.5 Compatible Products	5
1.6 Glossary	5
2 - ABOUT THE ARACHNIPOD	6
2.1 Description and Kit Contents	6
2.2 Basic Specifications	10
2.3 Components and Accessories	12
3 - INSTRUCTIONS FOR USE	17
3.1 General Safety Instructions	17
3.2 Before Each Use	17
3.3 General Set Up Instructions	18
3.4 Configuring the Arachnipod	21
Essential Configurations:	
Tripod, Quadpod, Bridge System	21-23
Advanced Configurations:	
Gin Pole, A-Frames, Handrail Recovery Monopole	24-26
Installation Instructions:	
Lazy Leg Adaptor	27
Equipment Bracket 2:1 Rigging	28
4 - PRINCIPLES OF EDGE MANAGEMENT	29
5 - STABILISING THE ARACHNIPOD	32
6 - INSPECTION & MAINTENANCE	38
6.1 Cleaning, Storage and Transportation	38
6.2 Inspection and Maintenance	38-46
Form: Arachnipod Kit Records	47
Form: Regular and Annual Inspection Record	48
7 - DETAILED SPECIFICATION & PARTS	49
Specifications	49
Kits and Parts	50
Declaration of Conformity	52

NOTICE

EMPLOYER: It is your responsibility to ensure all users are instructed and trained in the correct use and maintenance of the equipment. Once equipment is issued, it is assumed this has been completed.

USER: Only competent users should use this equipment. It is your responsibility to read and understand these instructions and be properly trained in the use of this equipment. Always use equipment safely and properly. Check equipment before and after each use

GENERAL: This document is not intended as a substitute for appropriate training. Training, practice and experience in technical rigging are essential for safe use. Modifying the equipment can cause injury and damage and will nullify any warranty and place full responsibility for any accident or injury on the equipment owner.

Working at heights and in confined spaces can be dangerous. If you use Ferno equipment, you are responsible for learning and observing safe techniques. Ferno Australia disclaims all liability for any injury or loss arising from the use of this equipment when any of its components are damaged or weakened by wear and tear.

1 - SAFETY INFORMATION

1.1 Warning



WARNING

Warning safety alerts indicate a potentially hazardous situation that, if not avoided, could result in injury or death.

1.2 Notice

NOTICE

Notices emphasise important, but not hazard-related information. Failure to follow Notices could result in product or property damage.

1.3 Tip

Tip

Tips

Handy hints to make a task simpler, more efficient or your job a bit easier.

1.4 Product Lifespan Statement

The actual life span of the Arachnipod cannot be predicted exactly, as it is influenced by many factors including but not limited to frequency and intensity of use, environment, weather, storage conditions, etc.

For metallic products it is advisable to replace after 12 years from date of first commission, however the life span is theoretically indefinite with strict adherence to the maintenance and inspection guidelines contained within the user manual. Non-metallic components such as leg stoppers, and standard foot treads may require more frequent replacement.

If there is any doubt about the safety of the product, do not use and contact your safety representative or the manufacturer for further advice.

It is always recommended to review the manufacturer's instructions as a life span may be restricted due to application or applicable product standards.

1.5 Compatible Components

The use of the Arachnipod is limited to combinations of approved and registered components only. Examples include:

1. Retractable type fall arrestor with rescue winch according to EN360.
2. Rescue, lifting and descending devices according to EN361, EN341, EN1496, EN67, EN1891, EN1497 and any other relevant Standard pertaining to the task that is to be completed.
3. Approved and tested componentry by Ferno Australia.

Other combinations and components not meeting these standards and should not be used as they may compromise the safe operation of the system.

1.6 Glossary and Symbols



Anchor

Artificial High Direction (AHD) An elevated change-of-direction anchor point used to change the direction of the Main Line.

CEN/TS 16415:2013 and EN795:2012 Standard for anchor systems

Fall Hazard Any location or situation that exposes equipment or personnel to a fall.

Footprint The surface area between the feet of the configured Arachnipod.

Guy Line / Tension Rigging A tensioned line that stabilises and prevents the Arachnipod from toppling.

Hazard Zone An area usually within 2m (6 ft) from any edge in which a potential fall hazard exists.

kN Kilonewton



Load

Main / Working Line The primary line supporting the load.

MBS Minimum Breaking Strength

NB2797 Number of notified body for PPE

N/A Not applicable

PPE Personal Protective Equipment

Resultant Force The single linear directional force equal to the sum of all forces applied to an object.

Safety / Belay / Backup Line A second rope system used to support the load should the Main Line fail.

Tether Line A line used to prevent an object from falling over an edge.

Travel Restraint A lanyard, tether or safety line device that prevents a person from reaching the edge.

WLL Working Load Limit

2 - ABOUT THE ARACHNIPOD

2.1 Description & Kit Contents

The Arachnipod is a portable anchor device and is used for securing persons operating in situations where a fall from height may occur. The Arachnipod system adapts to most terrains to enable access to difficult locations such as confined spaces, sheer edges, steep terrain and voids.

Various Arachnipod components are combined in order to build an appropriate configuration for the job: from a simple tripod or quadpod through to more technical bridge systems, A-frames and gin poles or monopods.

ARACHNIPOD UNITS ARE AVAILABLE AS:

- Standard tripod
- Advantage tripod
- Quadpod
- Standard bridge
- Advantage Kit
- TEMS (Total Edge Management System) Kit

OPTIONAL ACCESSORIES

- Accessories can be combined with your existing Arachnipod unit to create more technical or complex configurations. This increases your choices when faced with a complex scenario.
- For explanations of of Arachnipod components and accessories, refer to section **Components & Accessories**, page 12 - 16.



STANDARD TRIPOD (APOD-STD)

FEATURES

- Rectangular, adjustable legs with leg pins
- Two stainless steel swivel eye bolt anchor points
- Stainless steel double-grooved pulley accommodates 8mm steel/stainless steel wire rope cable and fibre rope up to 13mm
- Each leg includes a stabilisation attachment point
- Standard feet pivot to adjust to ground variations and incorporates an aggressive non-slip tread pattern

IN THE BOX

- 1 x Standard tripod comprising 2 standard legs with eye bolts and 1 pulley leg
- 1 x Foot tether with rope grab
- 1 x Arachnipod standard bag

The above legs can be variously combined to build:

- Tripod
- A-Frame (Rigging Plate required, optional extra)
- Sideways A-Frame
- Handrail Recovery Monopole



There may be instances within this manual where Arachnipod models are shown with the original Standard Foot. Arachnipod will be supplied with the dual-function Standard Foot 2 as illustrated above on and after 24 August 2020.

ABOUT THE ARACHNIPOD



ADVANTAGE TRIPOD (APOD-ADV)

FEATURES

- Rectangular, adjustable legs with leg pins
- Two stainless steel swivel eye bolt anchor points
- Stainless steel double-grooved pulley accommodates 8mm steel/stainless steel wire rope cable and fibre rope up to 13mm
- The versatile Lazy Leg also functions as a Standard leg
- Each leg includes a stabilisation attachment point
- Standard feet pivot to adjust to ground variations and incorporates an aggressive non-slip tread pattern

IN THE BOX

- 1 x Advantage tripod comprising 1 Standard leg with eye bolt, 1 Lazy Leg with eye bolt and 1 Pulley leg
- 1 x Lazy Leg Adaptor (accessory)
- 1 x Foot tether with rope grab
- 1 x Arachnipod standard bag

These parts can be variously combined to build:

- Tripod
- A-Frame (Rigging Plate required, optional extra)
- Sideways A-Frame (Rigging Plate required, optional extra)
- A-Frame with Lazy Leg (Reverse Head and Quad Plate required, optional extra)
- Handrail Recovery Monopole



QUADPOD (APOD-QUAD)

FEATURES

- Rectangular, adjustable legs with leg pins
- Two stainless steel swivel eye bolt anchor points
- Two stainless steel double-grooved pulley accommodates 8mm steel/stainless steel wire rope cable, and fibre rope up to 13mm
- Each leg includes a stabilisation attachment point
- Standard feet pivot to adjust to ground variations and incorporates an aggressive non-slip tread pattern

IN THE BOX

- 1 x Quadpod made up of 2 Standard legs and 2 Pulley legs
- 1 x Quad Plate (accessory)
- 1 x Foot tether and rope grab
- 1 x Arachnipod standard bag
- 1 x Single leg bag

These parts can be variously combined to build:

- Tripod
- Quadpod (Quad Plate required, supplied)
- A-Frame (Rigging Plate required, optional extra)
- Sideways A-Frame (Rigging Plate required, optional extra)
- Handrail Recovery Monopole



STANDARD BRIDGE (APOD-S*B)

FEATURES

- The bridge system is a unique feature of the Arachnipod
- The bridge spans larger openings
- Beam provided with trolley, trolley positioning line and heads
- Four rectangular, adjustable legs provide support and stability
- Three load attachment eye bolts
- One stainless steel double-grooved pulley for 8mm steel/stainless steel wire rope, and fibre rope up to 13mm
- Each leg includes a stabilisation attachment point
- Standard feet pivot to adjust to ground variations and incorporates an aggressive non-slip tread pattern

IN THE BOX

- Standard Bridge (3 x standard legs, 1 pulley leg and 1 2m, 3m or 4m bridge)
- 1 x Quad Plate (accessory)
- 2 x Foot tether and rope grab
- 1 x Arachnipod standard bag
- 1 x Bridge bag

These parts can be variously combined to build:

- Tripod
- Quadpod (Quad Plate required, provided)
- A-Frame (Rigging Plate required, optional extra)
- Sideways A-Frame (Rigging Plate required, optional extra)
- Handrail Recovery Monopole
- Bridge System



ADVANTAGE KIT (APOD-ADV+)

FEATURES

- Rectangular, adjustable legs with leg pins
- Two stainless steel swivel eye bolt anchor points
- Stainless steel double-grooved pulley accommodates 8mm steel/stainless steel wire rope cable, and fibre rope up to 13mm
- The versatile Lazy Leg also functions as a Standard leg
- Each leg includes a stabilisation attachment point
- Standard feet pivot to adjust to ground variations and incorporates an aggressive non-slip tread pattern

IN THE BOX

- Advantage Tripod (1 each standard, pulley and Lazy Leg)
- 1 x Lazy Leg Adaptor
- 1 x Foot tether and rope grab
- 1 x Arachnipod standard bag
- 1 x **Advantage Accessory Kit containing essential extras:** (Refer to Figure A, page 9 for parts identification)
 - › 1 x Advantage Accessory Kit Bag **1**
 - › 1 x Reverse Head **2**
 - › 1 x Gin Head **3**
 - › 1 x Rigging Plate **4**
 - › 3 x Spike Feet **5**
 - › 1 x Quad Plate **6**

These parts can be variously combined to build:

- Tripod
- A-Frame (Rigging Plate required, supplied)
- Sideways A-Frame (Rigging Plate required, supplied)
- A-Frame with Lazy Leg (Quad Plate and Reverse Head required, supplied)
- Gin / Monopole (Lazy Leg and Gin Head required, supplied)
- Handrail Recovery Monopole

ABOUT THE ARACHNIPOD



TOTAL EDGE MANAGEMENT SYSTEM (APOD-TEMS)

FEATURES

- The top of the line Total Edge Management System includes all the equipment needed to manage just about any scenario
- The TEMS kit includes all the features of the Standard Bridge, with the addition of the Full Accessory Kit included.

IN THE BOX

- 2 x Standard leg with eye bolt
- 1 x Pulley leg
- 1 x Lazy Leg with eye bolt
- 1 x 2m, 3m or 4m Bridge
- 1 Lazy Leg Adaptor
- 2 x Foot tether and rope grab
- 1 x Arachnipod standard bag
- 1 x Bridge bag to suit bridge length
- 1 x **Full Accessory Kit** containing:
 - › 1 x Full Accessory Kit bag ①
 - › 4 x Hold Down Stakes ②
 - › 2 x Steps ③
 - › 1 x Equipment Bracket ④
 - › 1 x Gin Head ⑤
 - › 1 x Reverse Head ⑥
 - › 1 x Rigging Plate ⑦
 - › 1 x Quad Plate ⑧
 - › 4 x Spike Feet ⑨
 - › Spare Parts Pouch with 2 Spare Qik Link Head Pins, 1 Spare Leg Pin, 2 Spare Detent Pins, 8 M12 Tru-Bolts and 1 M12 Masonry Drill Bit ⑩
 - › 4 x Soft Ground Shoes ⑪

The Total Edge Management System can be configured as:

- Tripod
- A-Frame
- Sideways A-Frame
- A-Frame with Lazy Leg
- Quadpod
- Gin / Monopole
- Handrail Recovery Monopole
- Bridge System



2.2 Basic Specifications

Basic specifications for the Arachnipod models are shown in the table below. General specifications are rounded. For more detailed specifications, refer to Detailed Specifications, page 49.

Specifications	Standard Tripod	Advantage Tripod	Quadpod
Max. Inside Clearance Height	2671mm / 105"	2671mm / 105"	2671mm / 105"
Inside Feet Footprint	2533mm / 99.7"	2533mm / 99.7"	2551mm x 2171mm / 100.4"
Configured Device Weight	27kg / 60lb	26kg / 57lb	37kg / 82lb
Stowed in bag(s) Weight	35kg / 74lb	34kg / 75lb	Bag 1: 36kg / 79lb Bag 2: 10kg / 21lb
WLL External Anchor Point	400kg / 880lb at max. height	400kg / 880lb at max. height	400kg / 880lb at max. height
Minimum Breaking Strength	40kN	40kN	40kN
WLL Load Anchored to Leg	220kg / 485lb	220kg / 485lb	220kg / 485lb
Legs included in package	2 x Standard Legs 1 x Pulley Leg	1 x Standard Leg 1 x Pulley Leg 1 x Lazy Leg	2 x Standard Legs 2 x Pulley Legs
Certification	Certified in 3 and 4 leg configurations to CEN/TS 16415:2013 for maximum 2 persons and EN 795:2012 for single person use		

Specifications	Standard Bridge 2m / 3m / 4m Bridge	Advantage Kit Tripod & Accessory Kit	TEMS Kit Total Edge Management System																		
Max. Inside Clearance Height	2696mm / 106.1"	2671mm / 105"	2696mm / 106.1"																		
Inside Feet Footprint	2m: 3346mm x 2171mm / 131.7" x 85.5" 3m: 4346mm x 2171mm / 171" x 85.5" 4m: 5346mm x 2171mm / 210.5" x 85.5"	2533mm / 99.7"	2m: 3346mm x 2171mm / 131.7" x 85.5" 3m: 4346mm x 2171mm / 171" x 85.5" 4m: 5346mm x 2171mm / 210.5" x 85.5"																		
Configured Device Weight	2m: 57kg / 125lb 3m: 64kg / 141lb 4m: 71kg / 156lb	26kg / 57lb	2m: 57kg / 125.6lb 3m: 64kg / 141lb 4m: 71kg / 156.5lb																		
Stowed in bag(s) Weight	<table border="1" style="width: 100%; border-collapse: collapse;"> <thead> <tr> <th style="color: red;">2m Bridge</th> <th style="color: red;">3m Bridge</th> <th style="color: red;">4m Bridge</th> </tr> </thead> <tbody> <tr> <td>Bag 1[†]: 34kg / 75lb</td> <td>Bag 1[†]: 34kg / 75lb</td> <td>Bag 1[†]: 34kg / 75lb</td> </tr> <tr> <td>Bag 2[^]: 40kg / 88lb</td> <td>Bag 2[^]: 51kg / 112lb</td> <td>Bag 2[^]: 63kg / 139lb</td> </tr> </tbody> </table>	2m Bridge	3m Bridge	4m Bridge	Bag 1 [†] : 34kg / 75lb	Bag 1 [†] : 34kg / 75lb	Bag 1 [†] : 34kg / 75lb	Bag 2 [^] : 40kg / 88lb	Bag 2 [^] : 51kg / 112lb	Bag 2 [^] : 63kg / 139lb	Bag 1[†]: 33kg / 73lb Accessory Kit: 5.5kg / 12lb	<table border="1" style="width: 100%; border-collapse: collapse;"> <thead> <tr> <th style="color: red;">2m Bridge</th> <th style="color: red;">3m Bridge</th> <th style="color: red;">4m Bridge</th> </tr> </thead> <tbody> <tr> <td>Bag 1[†]: 34kg / 75lb</td> <td>Bag 1[†]: 34kg / 75lb</td> <td>Bag 1[†]: 34kg / 75lb</td> </tr> <tr> <td>Bag 2[^]: 40kg / 88lb</td> <td>Bag 2[^]: 51kg / 112lb</td> <td>Bag 2[^]: 63kg / 139lb</td> </tr> </tbody> </table> <p style="text-align: center;">Full Accessory Kit: 12kg / 26lb</p>	2m Bridge	3m Bridge	4m Bridge	Bag 1 [†] : 34kg / 75lb	Bag 1 [†] : 34kg / 75lb	Bag 1 [†] : 34kg / 75lb	Bag 2 [^] : 40kg / 88lb	Bag 2 [^] : 51kg / 112lb	Bag 2 [^] : 63kg / 139lb
2m Bridge	3m Bridge	4m Bridge																			
Bag 1 [†] : 34kg / 75lb	Bag 1 [†] : 34kg / 75lb	Bag 1 [†] : 34kg / 75lb																			
Bag 2 [^] : 40kg / 88lb	Bag 2 [^] : 51kg / 112lb	Bag 2 [^] : 63kg / 139lb																			
2m Bridge	3m Bridge	4m Bridge																			
Bag 1 [†] : 34kg / 75lb	Bag 1 [†] : 34kg / 75lb	Bag 1 [†] : 34kg / 75lb																			
Bag 2 [^] : 40kg / 88lb	Bag 2 [^] : 51kg / 112lb	Bag 2 [^] : 63kg / 139lb																			
WLL External Anchor Point	At max. height and mid-beam 2m: 280kg / 616lb * 3m: 230kg / 506lb * 4m: 190kg / 418lb *	400kg / 880lb at max. height	At max. height and mid-beam 2m: 280kg / 616lb * 3m: 230kg / 506lb * 4m: 190kg / 418lb *																		
Minimum Breaking Strength	At max. height and mid-beam 2m: 28kN ** 3m: 23kN ** 4m: 19kN **	40kN	At max. height and mid-beam 2m: 28kN ** 3m: 23kN ** 4m: 19kN **																		
WLL Load Anchored to Leg	2m: 220kg / 485lb 3m: 220kg / 485lb 4m: 190kg / 418lb	220kg / 485lb	2m: 220kg / 485lb 3m: 220kg / 485lb 4m: 190kg / 418lb																		
Legs included in package	3 x Standard Legs 1 x Pulley Leg	1 x Standard Leg 1 x Pulley Leg 1 x Lazy Leg	2 x Standard Legs 1 x Pulley Leg 1 x Lazy Leg																		
Certification	Certified in 3 and 4 leg configurations to CEN/TS 16415:2013 for maximum 2 persons and EN 795:2012 for single person use																				

* The Bridge trolley WLL is 250kg / 550lb (ultimate strength 24.5kN)

** The Bridge beam MBS will differ depending on where the load is positioned along the beam. On a 2m bridge beam, the safety factors reduce from 10:1 to <7:1 as the trolley moves from the centre to the end of the beam.

[†] Tripod Bag

[^] Bridge Bag

ABOUT THE ARACHNIPOD

Dimensions: Tripod

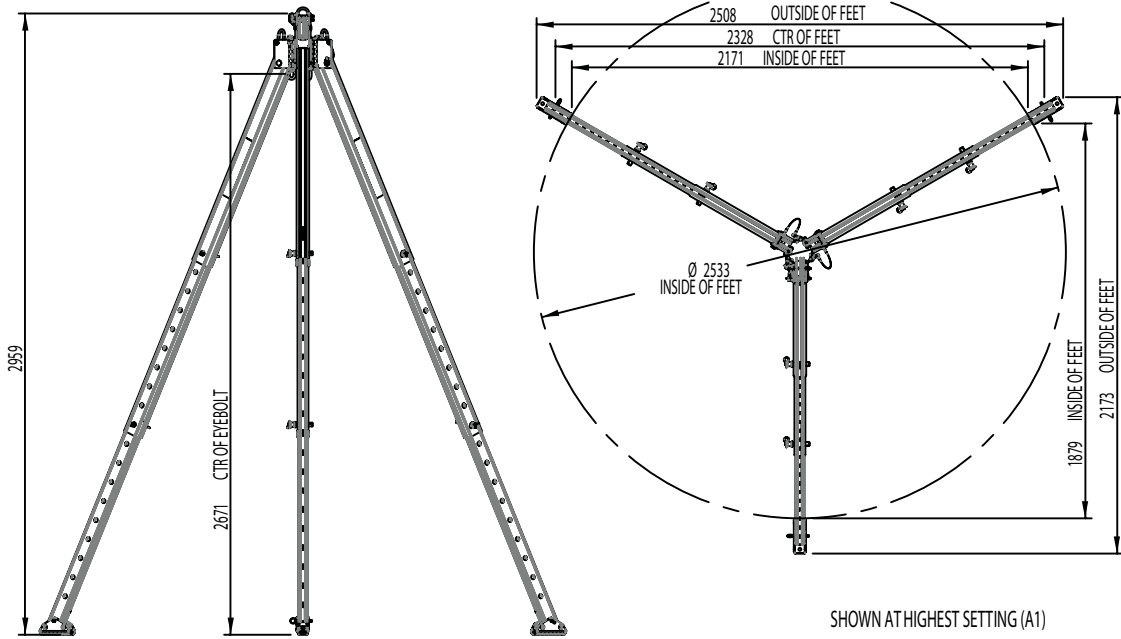

Dimensions: Quadpod

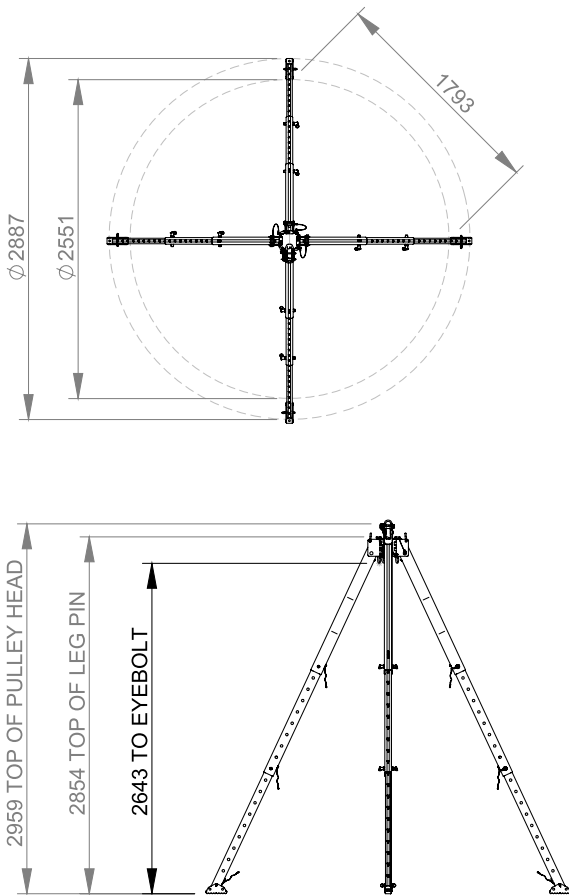

Dimensions: Bridge System

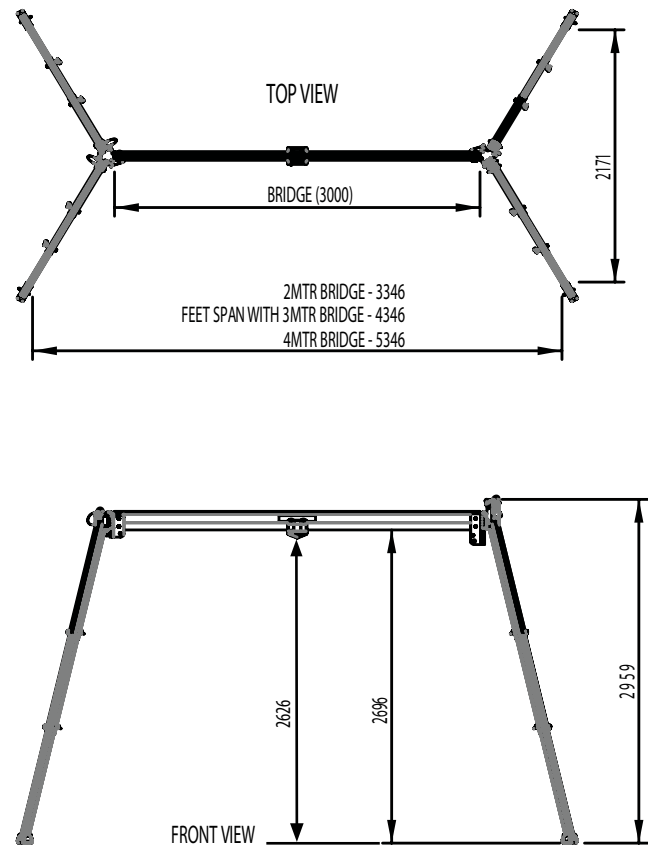

2.3 Components & Accessories

ARACHNIPOD LEGS

All Arachnipod legs (Figure 1) are made up of three telescopic sections, a head and a foot socket for attachment of a foot. All legs are supplied with a Standard foot and feature alpha-numeric labels to aid communication during the setting up of leg heights.

The patented leg heads are designed with a cut-out edge which forms a movable hinge when one head is slotted together with another leg.

There are three styles of Arachnipod legs, distinguished by their heads: Standard, Pulley and Lazy Leg. All heads are fitted with a stabilisation attachment point.

Legs join together via the leg heads and secure in place with Qik Link pins. By removing a Qik Link head pin, this system enables an Arachnipod tripod to be stored flat for easy transportation, and for rapid set-up.

Standard Leg

The Standard leg (Figure 2) has a red head with:

- One rated load attachment point (360° swivelling eyebolt)
- Stabilisation attachment point (D-shackle)

Pulley Leg

A Pulley leg (Figure 3) can be used in place of a Standard leg to add a pulley function to a tripod or A-frame configuration. It is also used as a handrail monopole.

The double grooved pulley accommodates either fibre rope up to 13mm diameter, or steel/stainless steel wire rope cable up to 8mm. A detent pin prevents the rope or cable from escaping the pulley grooves. The Pulley leg has a red head with:

- Double groove pulley
- Removable stabilisation point

Lazy Leg

The Lazy Leg's head (Figure 4) is blue coloured and designed to pivot so the leg can be angled to a range of 180°. Lazy Leg 2 (effective August 2020) features an additional eye bolt (not available with original Lazy Leg), plus a removable stabilisation point. The Lazy Leg may be used to configure:

- A Gin pole (gin head required)
- An A-frame with Lazy Leg (two additional legs, reverse head and quad plate required).

The Lazy Leg can be converted to a Standard leg by locking its pivoting head with a Lazy Leg Adaptor.

NOTE: Due to its slightly different profile, Lazy Leg 2 can only be used with Gin Head 2.

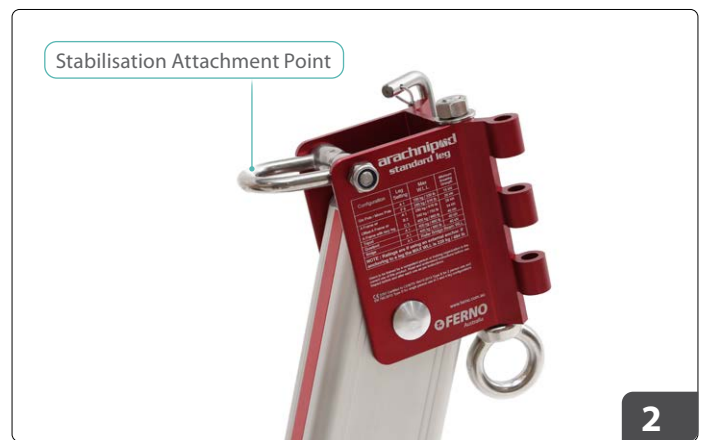
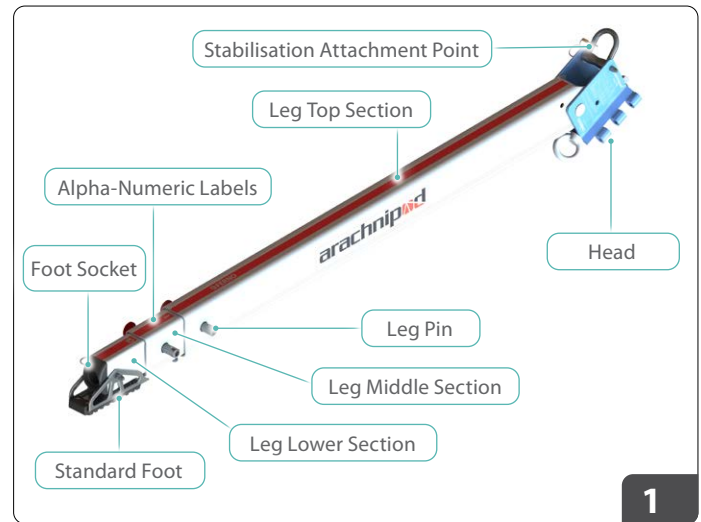

ABOUT THE ARACHNIPOD

ARACHNIPOD FOOT OPTIONS

The Arachnipod system offers various foot options to suit various ground surfaces and conditions. Feet are secured to the base of the lower leg with a detent pin.

Leg with Standard Foot

The Standard Foot (Figure 5) is ideal for flat surface applications such as concrete. Lashing holes are provided at front and rear of the foot to accommodate leg restraint rope or other lashing technique.

For uneven surfaces, the Standard Foot may be pivoted to deploy its spiked tips. Unused lower leg holes can be used with the leg restraint rope or for other lashing techniques.



Spike Foot

The Spike Foot (Figure 6) has a round end and a spike end. It is reversible. The spiked end features a stainless steel tip which extends the service life of the spike. It is used for point loading and ground penetration applications.

The round end is used in situations where the spike may damage or scratch the supporting surface.

One end of the spike foot fits into the foot socket in the base of the leg, and held in place with a detent pin (Figure 6).

Included in the Advantage and the Full Accessory Kit, or sold separately.



Soft Ground Shoe

The Soft Ground Shoe (Figure 6) fits over the spike foot and clips to the foot socket. It is used to limit ground penetration in soft ground applications. Included in the Full Accessory Kit, or sold separately.

Hold Down Stake

A Hold Down Stake is used to secure a standard foot to the ground (Figure 7).

- Insert the foot-locating spike through one of the holes in the standard foot. Ensure this foot locating spike remains in the foot while hammering the hold down stake into position.
- Using a soft-faced or shot-filled hammer, hammer on the impact plate until the stake is half way into the ground.
- Pause to check the alignment of the foot locating spike, then continue to drive the stake into the ground.

Included in the Advantage and the Full Accessory Kit, or sold separately.

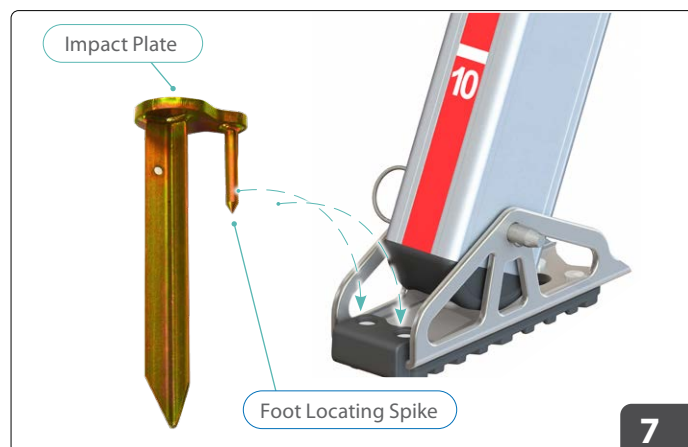

Tru Bolt

12mm Tru Bolts (Figure 8) which are supplied in the Full Accessory Kit and available from hardware stores, can be used in place of hold down stakes to secure the foot to concrete and other hard rock surfaces.

Tru Bolts fit through the same holes in the standard foot as the hold down stake (Figure 8).

Included in the Full Accessory Kit, or sold separately.

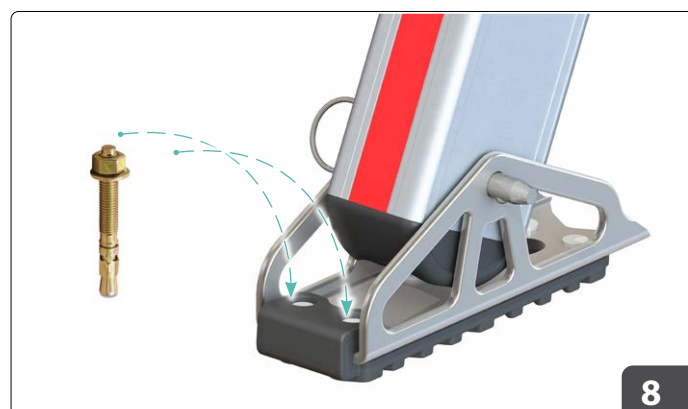

OPTIONAL ACCESSORIES (For product codes and comprehensive list of spare parts, refer Arachnipod Kits & Parts, page 50)



Quad Plate

A Quad Plate is used in the formation of a quadpod or A-Frame with Lazy Leg. It helps to form and maintain the shape of the configured head. Included in the Advantage and Full Accessory Kits, or sold separately.



Reverse Head

The Reverse Head is used in the formation of an A-frame with Lazy Leg. When fitted, it enables two legs to connect at 180°. Included in the Advantage and Full Accessory Kits, or sold separately.



Lazy Leg Adaptor

The Lazy Leg Adaptor converts a Lazy Leg into a standard leg. Included with kits that include a Lazy Leg, or sold separately.



Rigging Plate

The Rigging Plate is used to provide additional stabilisation attachment points when two legs are connected as an A-frame. The Rigging Plate is not for live loads. Included in the Advantage and the Full Accessory Kit, or sold separately.



Gin Head

The Gin Head may be used as an anchor plate, or combined with a Lazy Leg to form a gin pole. There are two versions of the Gin Head, both performing the same function. Gin Head 2 is compatible with both the Lazy Leg and Lazy Leg 2. The original Gin Head (DOM prior to 24 August 2020) fits the Lazy Leg.

Included in the Advantage and Full Accessory Kits, or sold separately.



Equipment Bracket

The Equipment Bracket is designed to be attached to the middle leg section and provides an additional tie-off and/or anchor point. When the leg it is attached to is used as an anchor, the WLL of the Arachnipod is reduced to 220kg. This attachment point may only be used if the main line passes through a change of direction pulley at the head of the configuration.

Included in the Full Accessory Kit, or sold separately.

ABOUT THE ARACHNIPOD



15

Step

The Step enables an operator to reach and adjust high rigging without having to lower the whole set up. The Step attaches to the middle or lower leg sections. For enhanced safety, the Step should only be attached to the inside of the leg so the leg is between the user and the void.

Steps are not rated for load applications. Before using the Step, ensure the operator is secured with appropriate fall protection and PPE. Included in the Full Accessory Kit, or sold separately.



16

Winch with Cable

The Arachnipod Winch with cable is fitted with a bracket that mounts to the middle section of any leg. The winch is available in 10m, 20m and 25m cable lengths.

Type 2 Winch with a WLL of 220kg / 485lb.

Sold separately.



17

Fall Arrest Block with Retrieval Winch

The APOD-FA Type 3 fall arrest block is supplied with a bracket that mounts to the middle section of any supporting leg. 15m length.

WLL 136kg / 300lb. Sold separately.



18

APOD-FBA Fall Arrest Block Adaptor

This adaptor enables SALA Type 3 fall arrest blocks, Pelsue winches and other similar-shaped blocks to be attached to an Arachnipod leg. Sold separately.



19

I.K. Fall Arrest Block Adaptor

The I.K. Adaptor enables an IKAR 12m, 18m or 24m inertia reel or similar-shaped fall arrest block to be attached to an Arachnipod leg.

Sold separately.



20

Bridge Kit

The Bridge Kit includes a bridge beam with trolley (2m, 3m or 4m length), a standard leg, foot tether and rope grab plus storage bag. This kit is used to upgrade the functions of an Arachnipod tripod to a bridge system.

Sold separately. Note: Kit illustrated with original Standard Foot. The next generation Standard Foot 2 (part # 90-0472) is supplied with all Arachnipod units after 24/08/2020



Lazy Leg Extension Kit

When a Lazy Leg is used as a compression member and extra length is required, the APOD-EKLL Extension Kit extends the length of the Lazy Leg by 1.7m / 67".

Sold separately.



Bridge Ratchet Kit

The Bridge Ratchet Kit includes everything needed to stabilise the Arachnipod bridge system. The kit includes 15m ratchet straps, 1200mm round slings, 2500mm snake slings and round slings neatly packed into a handy grab and go bag.

Sold separately.

3 - INSTRUCTIONS FOR USE

3.1 General Safety Instructions

1. The Arachnipod and associated hardware must always be secured to prevent it from tipping and falling over. The Arachnipod may become unstable if used without an assessment of the resultant force and direction. Additional rigging may be required to ensure complete stabilisation.
2. Ensure the Operator is in good physical and mental health and is trained and competent in the use of the device. The Operator must employ all relevant PPE for the job prior to commencement of working at height. PPE may include, but is not limited to a harness, lanyard, helmet, gloves and appropriate foot wear.
3. Ensure you have a rescue plan in place prior to working at height or confined space. A rescue plan is mandatory and all operators within the team must be aware of it prior to commencing work.
4. Do not alter, modify or tamper with the Arachnipod in any way or form. The Arachnipod may not be rectified or serviced by any person unless they are appropriately trained and authorised by Ferno Australia.
5. When the Arachnipod is used as part of a fall arrest system, the User must be equipped with a means of limiting the maximum dynamic forces exerted on the user during the arrest of a fall to a maximum of 6kN.
6. A lanyard assembly should be secured to an anchorage point which is at a level that will result in the minimum free fall and the least total fall distance consistent with the wearer's ability to carry out work tasks.
7. When making a connection to any point on a harness which cannot be seen by the wearer of the harness, it should either be made before putting the harness on, or the connection should be connected or checked for security by a second person.
8. Always ensure anchor points are positioned to avoid a pendulum effect during a fall which may cause body contact with structures or machinery below. The maximum angle from the anchor point must not exceed 15° either side of the centre of the anchor point.
9. If any part of an assembly is to be exposed to chemicals such as caustic materials or hazardous atmospheres, the user should consult Ferno Australia to determine whether the part is suitable for continued use.



WARNING

- Do not use the Arachnipod beyond its specified limitations, or for any purpose other than that for which it is intended.
- Ensure the compatibility of equipment used within the system. Dangers may arise when the safe function of any one item of equipment is affected by or interferes with the safe function of another.
- Do not use your Arachnipod® if any parts are missing.

3.2 Before Each Use

Operator Inspection

The product should be inspected by a competent person before and after each use to ensure it functions correctly and all components are damage free.

A guide is provided below for use in conjunction with your approved workplace protocols.

For periodic and annual inspections, comprehensive instructions are provided in the **Inspection and Maintenance** section, page 38-56.

Inspect the Arachnipod for:

1. Do the legs fit together and extend smoothly?
2. Are the legs bent, cracked or deformed?
3. Are all fasteners (e.g. bolts, pins) present and securely tightened?
4. Is retaining hardware on pins present and in good condition?
5. Are the pins in good condition and functioning correctly?
6. Are the pulleys in good condition and functioning correctly?
7. Do any plastic parts show signs of wear or chemical damage?
8. Are the feet and lashing holes showing signs of deformation, damage and sharp edges?
9. Is the adjustable foot tether present and in good condition?

Refer any signs of deterioration to a competent person for a decision on the safety and serviceability of the product. If in doubt, tag it out!

NOTICE

Operating in, or exposing the Arachnipod to extreme temperatures, caustic chemicals, hazardous environments or excessively rough handling / treatment may cause damage.

3.3 General Set Up Instructions

Assembling the Arachnipod is easiest with two or more people. Where possible, it is safest to configure the Arachnipod away from the edge before moving the unit into position with the help of several people. Once in position, secure the feet, tether and stabilise the Arachnipod.

Step 1) Joining legs together

All Arachnipod legs are made up of three telescoping sections, a head and a foot (Figure 1 on page 12). The patented leg heads are designed with a cut-out edge which forms a movable hinge when one head is slotted together with the head of another leg.

To join two legs together:

1. Remove Qik Link pins from the heads of the two legs being joined together. (Step 1 Figure 23)
2. Holding both legs in an upright position, join the two head edges so they interlock to form a hinge. (Step 2 Figure 23)
3. Insert the Qik Link head pin through the combined hinge channel to secure the two legs together. When fully inserted, a spring-loaded pin retainer at the base of the hinge will engage with, and prevent the Qik Link pin from accidental removal (Step 3 Figure 24).

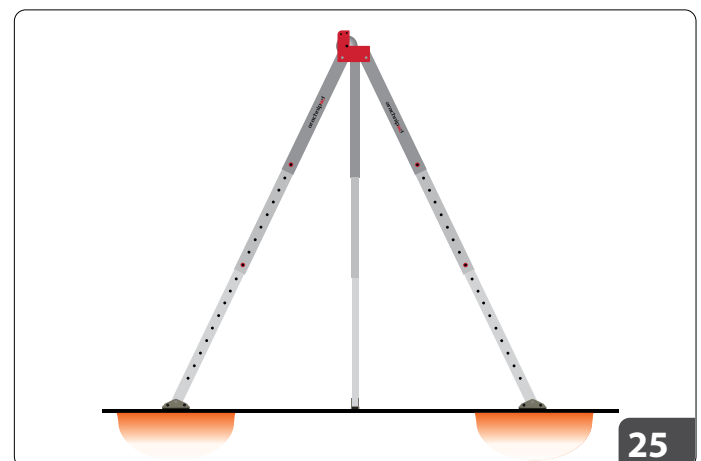
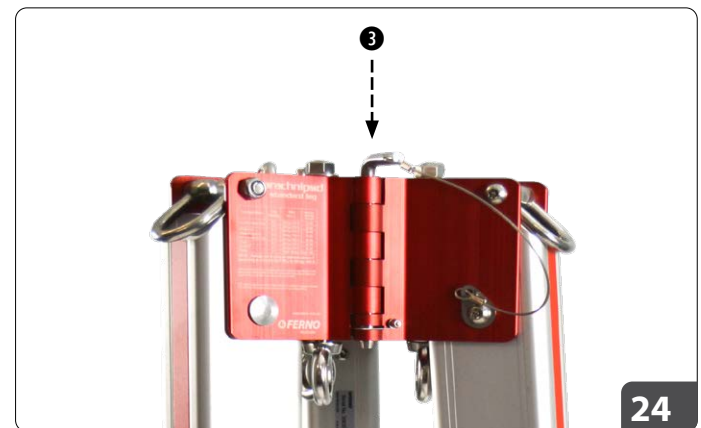
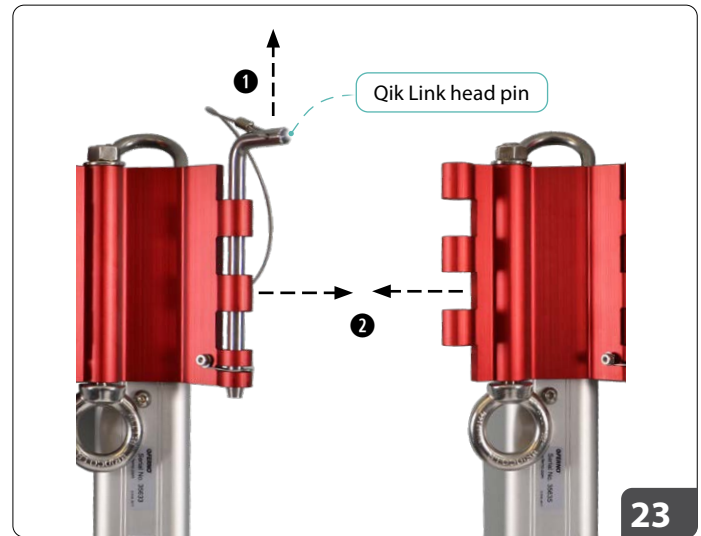

Tip

Inserting the Qik Link head pin

If the two leg heads are slightly misaligned, the Qik Link pin may not travel smoothly into and down the hinge channel. If this occurs, **do not force the pin**. Leave the pin partially inserted, then gently rattle / shake the two legs. This motion will align the two heads, allowing the pin to self-drop fully into the hinge channel.

For instructions on how to form a tripod, quadpod, and basic bridge system refer to “**ESSENTIAL ARACHNIPOD CONFIGURATIONS**” on page 21.

For gin pole, easel or A-frames and other advanced configurations, refer to “**ADVANCED ARACHNIPOD CONFIGURATIONS**” on page 24.

Step 2) Check the Surface (Figure 25)

- Make sure the substrate or floor below the Arachnipod feet can sustain the anticipated loads.
- Beware of soft ground and unsupported floors. Manage these accordingly.

ESSENTIALS: GENERAL SET UP INSTRUCTIONS

Step 3) Select feet to suit the surface

Consideration should be given to the ground surface Arachnipod will be operating on, and which foot style is most appropriate to surface conditions.

The Arachnipod is supplied with Standard feet which has a thermoplastic elastomer tread moulded to a stainless steel foot with integrated spike.

Additional foot options are available to provide the most stable solution for different ground conditions.

The Foot Options Table provides a quick reference of each foot's function.

Step 4) Extend Arachnipod legs

Extending legs is most efficiently performed when two or more people are involved. When only one person is available, this is still achievable by moving from leg to leg, making small adjustments to each leg.

Extending Arachnipod Legs

It is easier to raise and / or adjust the height of the legs when they are positioned close together, with all legs in an upright position.

Tip

- Remove **both leg pins** to release the three sections of leg.
- Extend the top section to desired height, then insert the leg pin to secure the top and mid section together.
- Next, extend the middle section to desired height and insert the leg pin to secure the middle and lower sections together.
- Check that all leg pins are securely engaged.

Ensure the Arachnipod remains stable while adjusting the legs.

WARNING

- When extending legs, sliding parts can create pinch points. Always wear appropriate PPE and gloves when setting up and operating Arachnipod.
- NEVER place fingers into leg pin holes.

Foot Options



Standard Foot

Supplied standard with all Arachnipod units. Ideal for flat or smooth surfaces, accommodates slight inclines.



Spike Foot

The spike tip of this reversible foot is ideal for point loading and ground penetration applications.



Spike Foot

The rounded end of the Spike Foot is good for wedging into corners or when supporting surfaces require additional care.



Soft Ground Shoe

The soft ground shoe is used in conjunction with the spike foot to limit the leg sinking in soft ground applications.



Hold Down Stake

Used in conjunction with a standard foot, the stake is driven into the ground to secure the foot.



Tru-bolts

Used to secure the standard foot to concrete and hard rock surfaces.

Step 5) Tether the feet

Position the legs then tether the Arachnipod’s feet to prevent the legs from splaying outwards and becoming unsafe.

Tethering the feet does not replace stabilisation of the unit.

To tether a tripod with standard feet:

1. Feed the foot tether rope through the inner hole of the standard foot and all subsequent feet.
2. When the foot tether is threaded through all feet, join the ends together to form a loop by feeding the tail end of the rope through the rope grab. Tighten to ensure there is no slack in the tether (Figure 26).

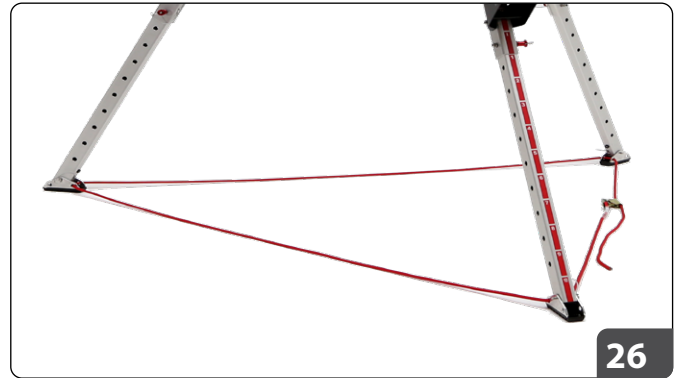

26

NOTICE

The unit may be damaged if legs splay apart while under load. Always tether the feet together when the Arachnipod is being used.

Step 6) Keep the Arachnipod head level where possible

This is easier to achieve with tripods and quadpod

- On flat surfaces all the legs will be the same length.
- On uneven surfaces the legs can be different lengths.
- Adjust the length of one or more legs so the Arachnipod’s head is level and directly over the opening or work area.
- **Figure 27:** Floor of different heights
- **Figure 28:** Sloping surface

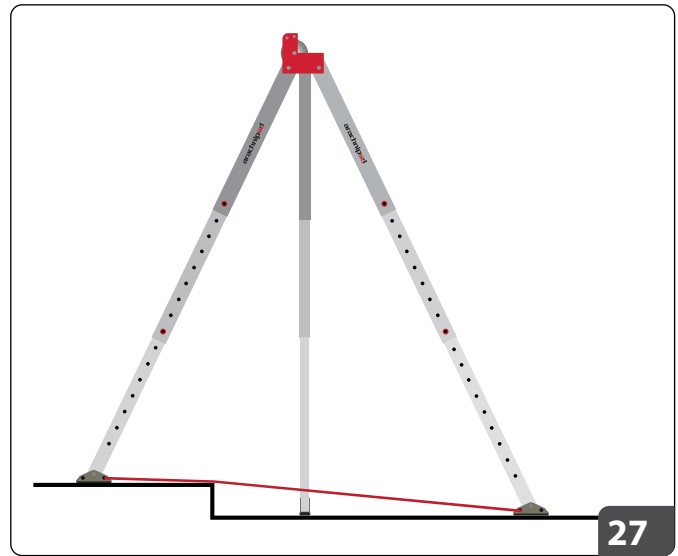

27

Step 7) Stabilise the Arachnipod

- Assess the resultant force and direction.
- Provide additional rigging as required to ensure stability of Arachnipod.
- For stabilisation guidelines, refer to “Stabilising the Arachnipod” on page 32

Step 8) Rig a two-rope system whenever possible

- Rig a two-rope system to provide a backup to both the main line and the edge management rigging.

Step 9) Carry out a safety check and continue to monitor Arachnipod for stability

- Visually check all anchors, rigging, karabiners, friction devices and PPE before committing anyone to the edge. Travel restraints must be provided for persons working close to the edge.
- Many factors can change during operation and affect the stability of the Arachnipod. Continuously monitor the Arachnipod and if any instability is detected, the safety line can be set to safely hold the load while adjustments are made.

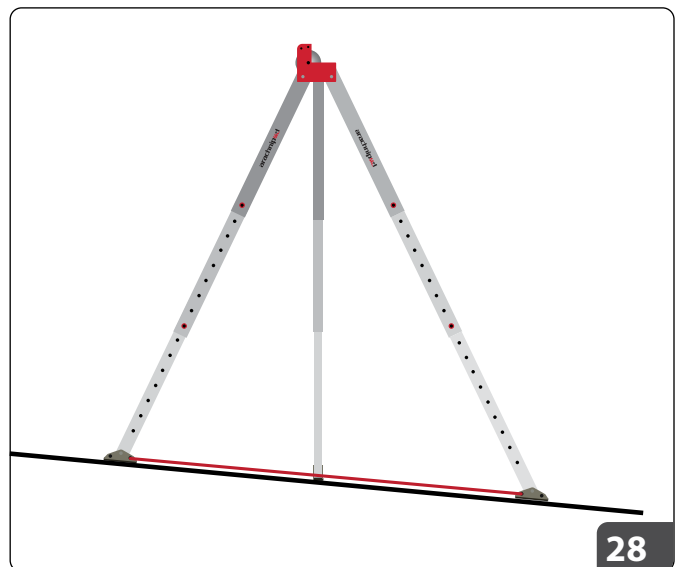

28

ESSENTIAL ARACHNIPOD CONFIGURATIONS

This section covers how to assemble Arachnipod into different configurations only. It does not contain set up instructions which are provided in General Set Up, pages 18–20.

3.4 Configuring the Arachnipod

Tripod assembly

A tripod provides simple access to confined space entry points such as manholes and voids.

Arachnipod components needed:

- Three Arachnipod legs

To assemble:

1. Select three Arachnipod legs for the tripod.
2. Stand the three legs in an upright position next to each other.
3. Align and join the leg heads together as described in **General Set Up**, page 18.
4. Check all Qik Link pins are fully engaged into the head hinges.

The tripod must be stabilised to prevent unwanted movement and failure. Refer “**Stabilising the Arachnipod**” on page 32.

Quadpod assembly

An Arachnipod Quadpod provides greater stability within the system, and is more versatile by allowing access to entry areas that are larger such as trenched areas and wider openings to a maximum of 1800mm x 1800mm, or more complex like convex and concave surfaces.

Arachnipod components needed:

- Four Arachnipod legs
- Quad plate

To assemble: (Figure 30, 31)

1. Select four Arachnipod legs for the quadpod. If two Pulley Legs are used in the quadpod formation, position them opposite each other.
2. Align and join three legs together as described on page 18. Rotate the outer legs at right angles to the middle leg to form a U-shape.
3. Slot the fourth leg to these outer legs but do not insert the head pins yet.
4. Slide the quad plate over the top of the combined leg heads. The holes in the quad plate should line up with the leg head hinges.
Note: If a pulley leg is used, ensure the quad plate’s indented side faces toward the pulley. The indented cut-out leaves room for the pulley to function.
5. Lock the quad plate and legs together with the head pins.

The Quadpod must be stabilised to prevent unwanted movement and failure. Refer “**Stabilising the Arachnipod**” on page 32.

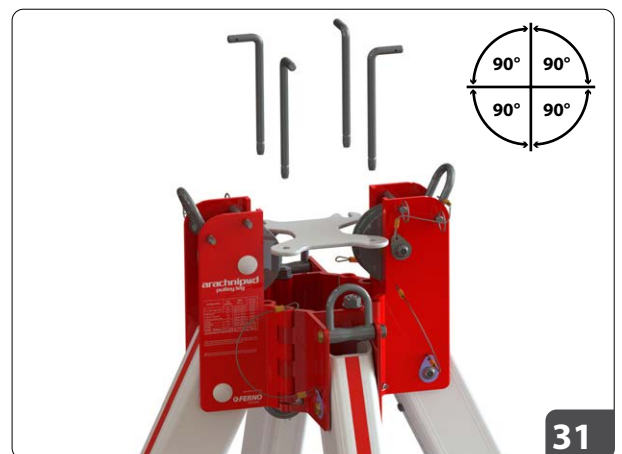
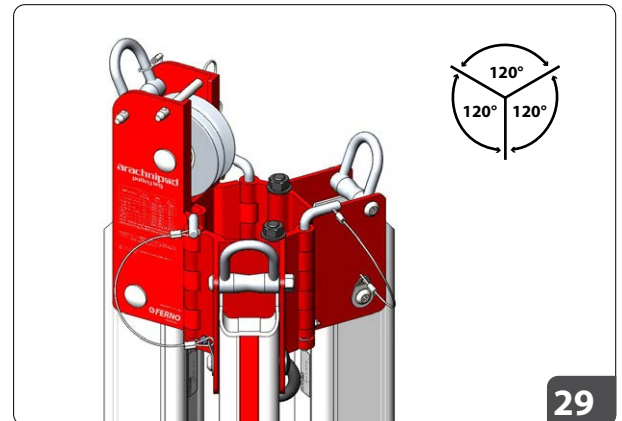

Bridge assembly

An Arachnipod Bridge (Figure 32) is used for spanning larger openings or voids where a regular tripod, A-Frame or quadpod would not be able to. These include trenches, large holes, mine and lift shafts.

Bridge beams are available in lengths of 2m, 3m and 4m. Bridges add a panning capability that is well suited to trench rescue and confined space applications. The Arachnipod Bridge is fitted with a trolley which is hauled along the length of the beam with the trolley positioning line. This is a single person operation.



32

An **English Reeve** highline system (Figure 33) is recommended because it negates the need for any additional trolley stabilisation. A tie-off point has been included in the Bridge design (Inset B), to facilitate English Reeve rigging.

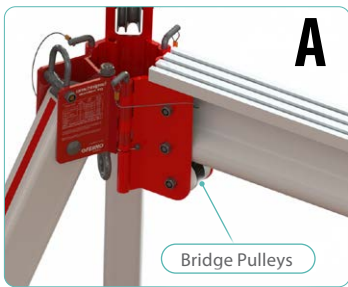

A

Bridge Pulleys

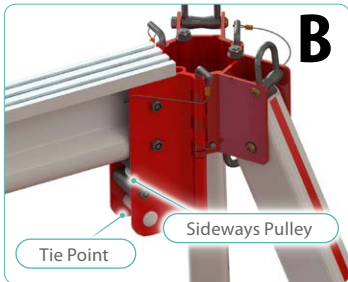

B

Tie Point

Sideways Pulley

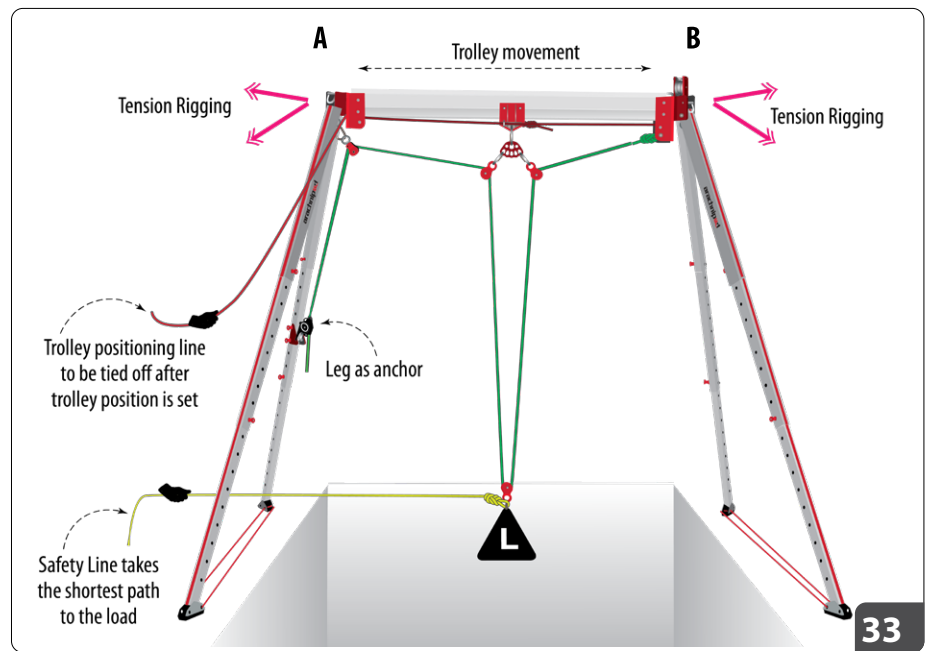

33

A **mechanical advantage hauling system** (Figure 34) can be suspended directly from the trolley provided it includes an integrated braking system to remove lateral forces at times when it is not raised or lowered.

The FERNO RALF 3:1 or 5:1 pulley kit, sold separately, is ideal for use with the Arachnipod Bridge System. The RALF kit is a pre-rigged mechanical advantage system incorporating a brake and remote release for raising and lowering.

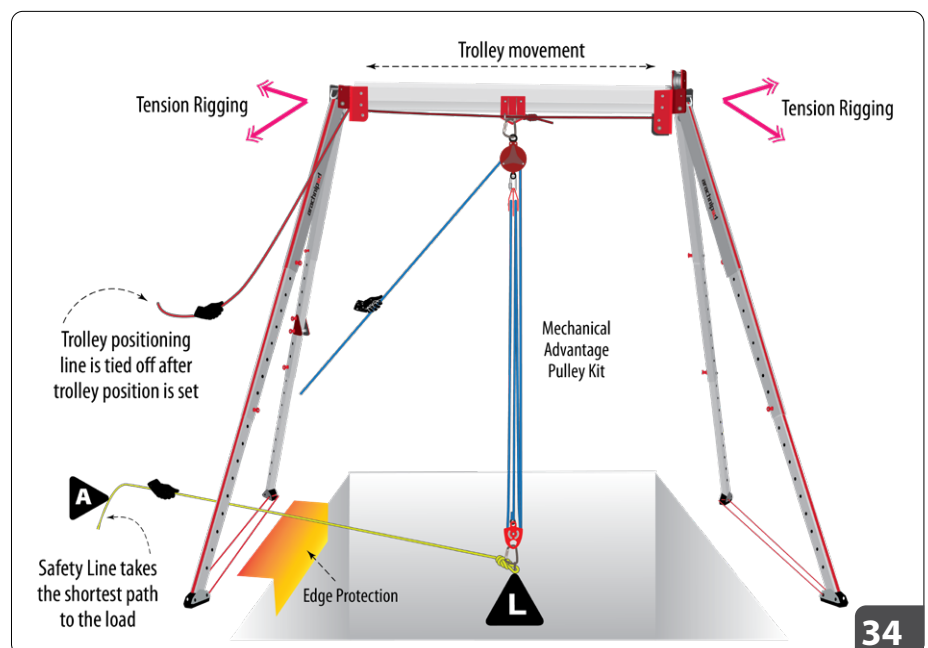

34

ESSENTIAL ARACHNIPOD CONFIGURATIONS

Due to its size, a bridge system is best assembled with three or more people:

- At least one person per set of legs
- At least one or more people for the bridge depending on its length, and the size / strength of operators.

Arachnipod Components needed:

- 4 x Legs
- 1 x Bridge
- 2 x Foot tethers

To assemble:

The bridge is supported at each end by a set of two legs (essentially two A-Frames), Figure 35.

1. Fit two legs together, and insert a head pin into the cutout hinge to secure them together.
2. Turn the two legs inwards by 60 degrees as though forming a tripod (the bridge takes the place of the third leg).
3. Repeat Steps 1–2 to create the second set of legs.
4. Position a set of legs on either end of the bridge. **Do not splay the legs out yet.**
5. Lift and fit each end of the bridge to the two sets of legs, and insert the Qik Link head pins to secure the bridge to legs.
6. Splay the legs out to stabilise the structure (Figure 22).
7. Loosen the trolley and tie off to a leg on the working side. The leg pin makes a handy tie off point (Figure 36).
8. Raise the bridge to the desired height by extending the legs, following the procedure outlined in Step 4 General Set Up, page 19.
9. Lash each set of leg feet together.

The Bridge system must be stabilised to prevent unwanted movement and failure. Refer “Stabilising the Arachnipod” on page 32.

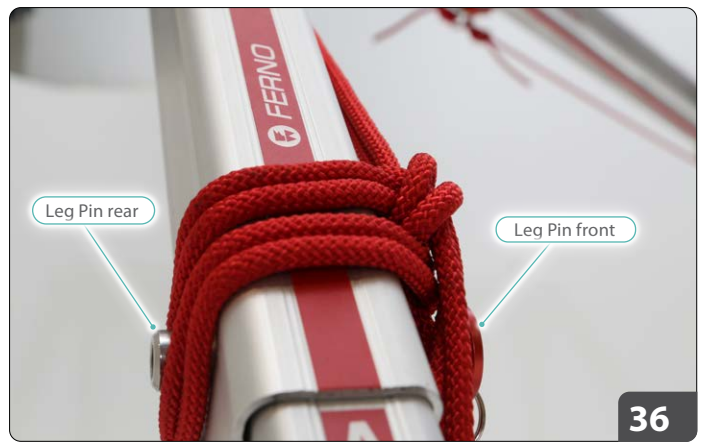

Gin Pole / Monopole assembly

A gin pole or monopole is ideal for situations where space is very limited and there is insufficient room to use an A-Frame or other configuration.

A gin pole may also be used as a separate component of a complex high directional system, or as an additional attachment point in a high line system.

In all instances, the gin pole will require stabilisation.

Arachnipod Components needed:

- 1 x Lazy Leg
- 1 x Gin Head

To assemble:

1. Remove the D-shackle attachment point (and Lazy Leg Adaptor Plug if fitted) from the Lazy Leg, then rotate its head 180°.
2. Insert the Gin Head into the Lazy Leg tube and lock into position with the detent pin (Figure 37).

The system must be stabilised to prevent unwanted movement and failure. Refer **“Stabilising the Arachnipod”** on page 32.

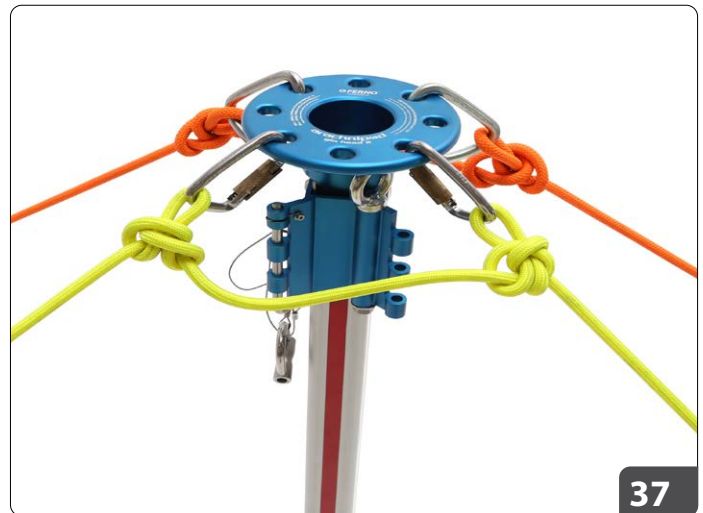

37

A-Frame

A conventional or off-set A-Frame is used in situations where an artificial high directional is required for high lines, or where there is insufficient space to accommodate more conventional systems such as a tripod.

Arachnipod Components needed:

- 2 x Legs
- 1 x Rigging Plate

To assemble:

1. Join the two legs heads 'back to back' (Figure 38)
2. Position the rigging plate over the combined heads, ensuring the fixing holes in the rigging plate line up with the heads' cut-out hinge channels.
3. Insert the two head pins which will lock the legs and rigging plate together (Inset - Figure 38).

The system must be stabilised to prevent unwanted movement and failure. Refer **“Stabilising the Arachnipod”** on page 32.



38

ADVANCED ARACHNIPOD CONFIGURATIONS

Sideways A-Frame

The sideways A-Frame (Figure 39), when formed with the Arachnipod pulley leg is ideal for situations requiring a high-directional to protrude past an edge such as cliffs, high-rise buildings and bridges.

An Arachnipod Rigging Plate should be used to provide additional tie-off points for stabilising the frame.

Arachnipod Components needed:

- 1 x Standard Leg
- 1 x Pulley Leg
- 1 x Rigging Plate

To assemble:

The Sideways A-Frame is constructed following the same method for the standard A-Frame.

The system must be stabilised to prevent unwanted movement and failure. Refer "Stabilising the Arachnipod" on page 32.



A-Frame with Lazy Leg (Figure 40 and 41)

An A-Frame with Lazy Leg enables the A-Frame to be braced against a solid object with the Lazy Leg acting as a compression and tension member. This allows the A-Frame legs to be operated in a more vertical position and closer to an edge. The design of the Reverse Head when incorporated with the Lazy Leg allows live loads to be positioned directly in the centre of the legs.

Arachnipod Components needed:

- 1 x Lazy Leg
- 2 x Legs
- 1 x Reverse Head
- 1 x Quad Plate

To assemble:

1. Remove the D-shackle from the Lazy Leg to remove the Lazy Leg Adaptor, if fitted.
2. Join the Pulley Leg and Lazy Leg together, and secure with a head pin.
3. Fit the third leg to the other side of the Lazy Leg and secure together with the head pin.
4. Rotate the two outer legs to form a U shape as though forming a quad pod. Instead of a fourth leg, insert the Reverse Head.
5. Position the quad plate over the leg heads ensuring the quad plate's cut-in edge faces the pulley. Insert the head pins through the quad plate fixing holes and into the head to lock everything together (Figure 41)

The system must be stabilised to prevent unwanted movement and failure. Refer "Stabilising the Arachnipod" on page 32.



Handrail Recovery Monopole

With the aid of an Arachnipod Pulley Leg, a handrail can be used to rig an artificial high directional to raise a person or rescue stretcher over an edge. The Pulley Leg enables an elementary system to be set up to retrieve a person or rescue stretcher over an edge, and through the lower handrail gap.

This method transfers the load through the Pulley Leg with the handrail so it is essential to first assess and ensure the handrail is capable of sustaining the load.

Arachnipod components needed:

- Pulley Leg

To assemble (Figure 42):

1. An assessment of the handrail is required to ensure it is suitable for this type of rigging
2. Consider the angle of the leg, and the resultant direction when assessing the handrail.
3. Tension rig the leg with rope or round lashing to keep it in place.
4. Square lash the top section of leg to secure it to the handrail.

⚠ WARNING

- **Incorrect rigging and use of this system is dangerous. This technique is recommended for advance users only.**

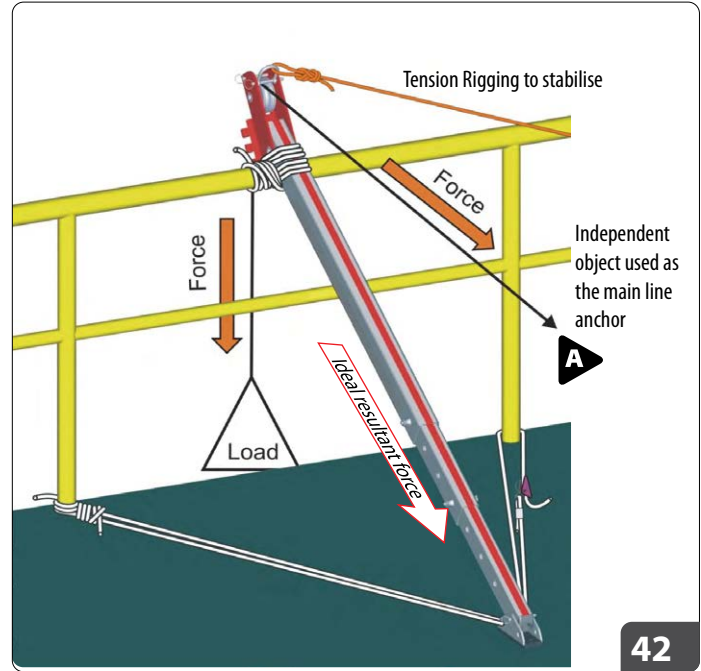

LAZY LEG ADAPTOR INSTRUCTIONS

Lazy Leg Adaptor Instructions

A Lazy Leg Adaptor (Fig 43) is used to convert a Lazy Leg into a Standard Leg. It is supplied with a detent pin which is used to secure the Lazy Leg Adaptor Plug into position.

When the Lazy Leg Adaptor is fitted, it limits the Lazy Leg's rotation capability from 180° to 25°.

Fitting the Lazy Leg Adaptor Plug

Tip

It is easier to fit the adaptor plug to the Lazy Leg before it is attached to other legs.

Installing the Lazy Leg Adaptor

Fit the Adaptor to the Lazy Leg before attaching it to other legs.

1. Remove the detent pin and stabilisation attachment point (D ring) at the head of the Lazy Leg.
2. Swivel the head so it is positioned parallel to the leg (Figure 44)
3. Insert the Lazy Leg Adaptor to the top of the Lazy Leg.
4. Fix the adaptor in place by re-inserting the detent pin through the corresponding hole in the leg and Lazy Leg Adaptor.
5. Re-fit the D-ring stabilisation attachment point to the leg.

The completed assembly should look like Figure 45.

The Lazy Leg will now operate like a Standard Leg.

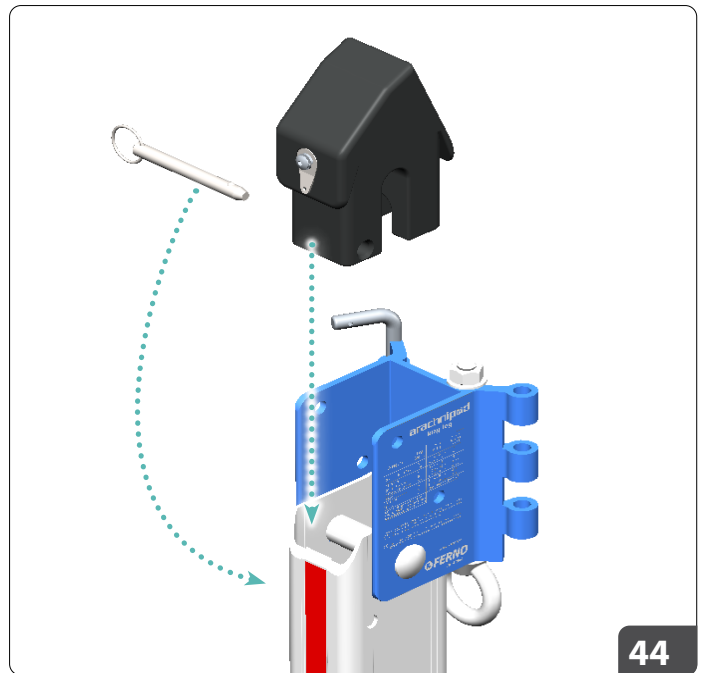
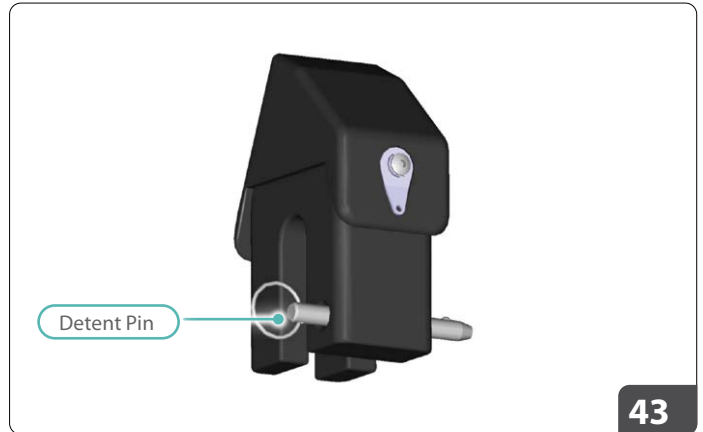

Equipment Bracket 2:1 Rigging Instructions

The Equipment Bracket is normally attached to the middle leg section. In the middle leg location, the Equipment Bracket has a 220kg safe working load (SWL), Figure 46.

1. Remove the pins from the Equipment Bracket
2. Position Equipment Bracket over the leg in desired position, aligning the bracket holes with leg holes
3. Re-insert the pins to secure the Equipment Bracket to leg.

It is permissible to attach the Equipment Bracket to the lower leg section only when it is used with mechanical advantage rigging as outlined in this instruction.

This method of rigging shares the load between the Equipment Bracket and the eye bolt so the SWL of the Equipment Bracket is not exceeded. The SWLs listed are derived from manufacturer testing and are provided below.

Rigging Method (Figure 47)

1. The main line is attached to the eye bolt
2. The main line is reeved through a pulley at the load
3. Reeve the main line through the pulley on the Pulley Leg head
4. The mainline is reeved through a friction device (ascender, descender or a rope grab) which is attached to the Equipment Bracket

The Arachnipod would normally be used in a tripod or quadpod configuration for this type of work.

Always secure the Arachnipod legs and stabilise the unit to suit the configuration and situation. Refer to "Stabilising the Arachnipod" on page 32

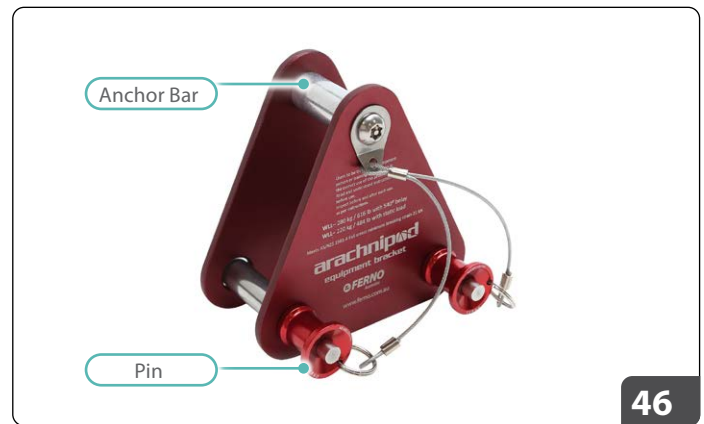

46

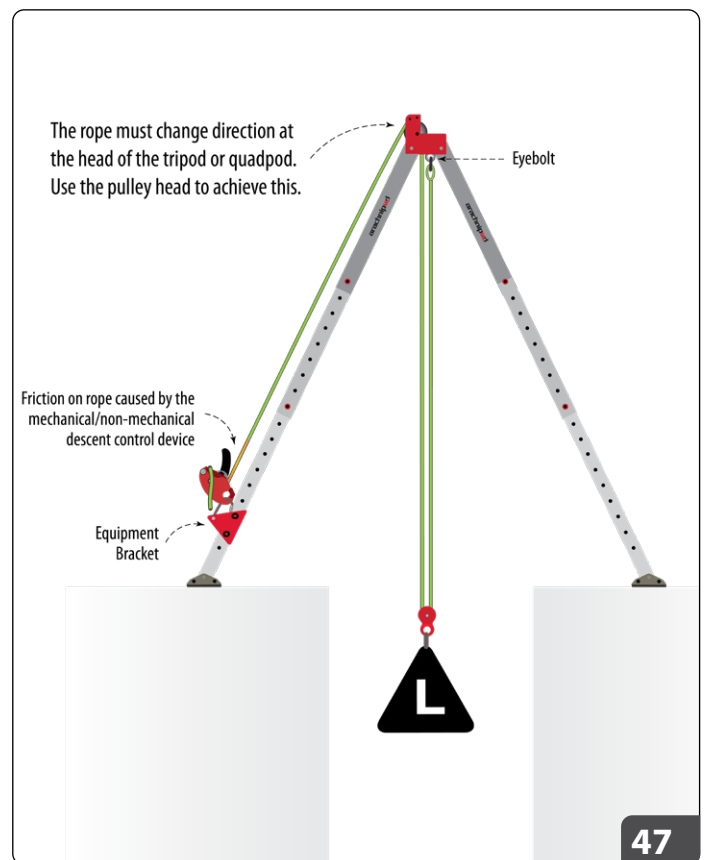

47

⚠ WARNING

Users to be trained in the use of this product by a competent person or training organisation.

Load Ratings

LEG SETTING	WLL	ULTIMATE STRENGTH
A1	150kg / 330lb	14.7kN
B2	220kg / 485lb	21.6kN
C3	300kg / 661lb	29.4kN

4 - PRINCIPLES OF EDGE MANAGEMENT

Edge Management is the assessment of the rigging tasks and equipment required to safely manoeuvre a load over an edge. A high change of direction is the key to successful edge management (Figure 48, 49) and the Arachnipod is an exceptionally versatile tool to facilitate this solution.

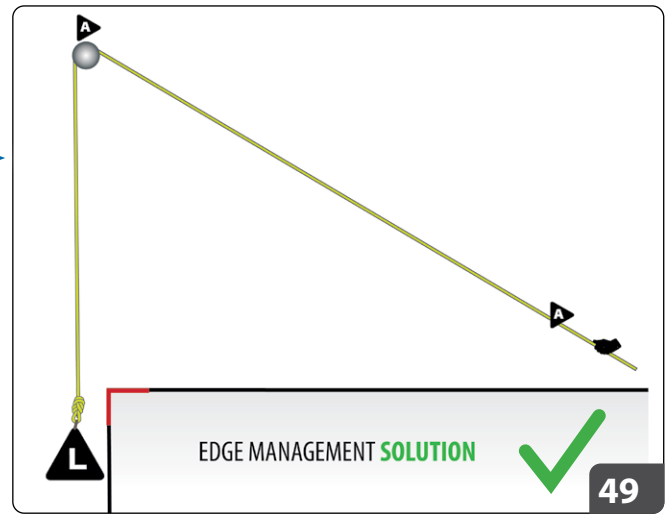
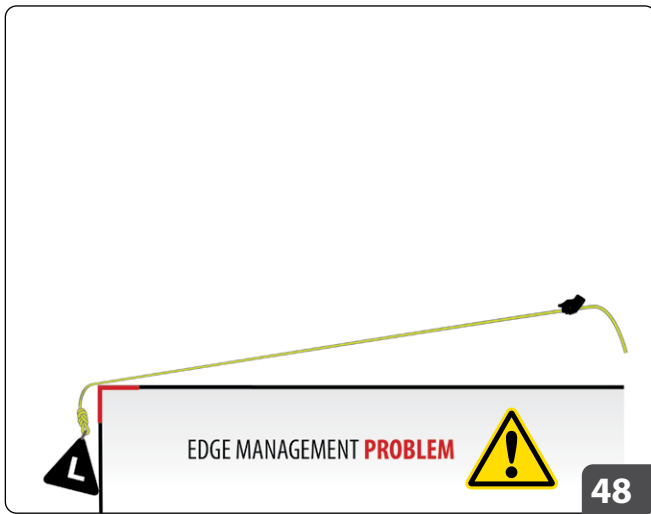

A critical point analysis of all rigging should form part of your edge management assessment. The purpose of the critical point analysis is to determine if the rigging relies on any single point to provide operator safety.

Two Rope System

A two rope system provides additional safety by backing up the main line and any edge management systems. The second line or safety line is rigged to take the shortest path from the anchor to the load (Figure 50).

- When the load is located below the edge, the safety line provides protection for both main line and edge management failures.
- When the load is located above the edge, the safety line provides limited protection for main line failures.

The Arachnipod can be rigged with the main line passing over the pulley head, and a rated hauling system can be used to progressively pick the safety line up as the load is raised (Figure 51).

This process provides additional protection against a main line failure. Ferno has a range of rated and pre-rigged hauling systems that are suitable for this task.

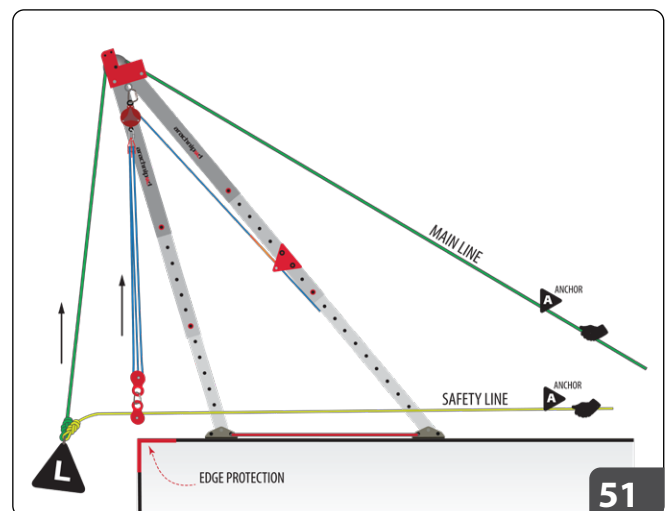
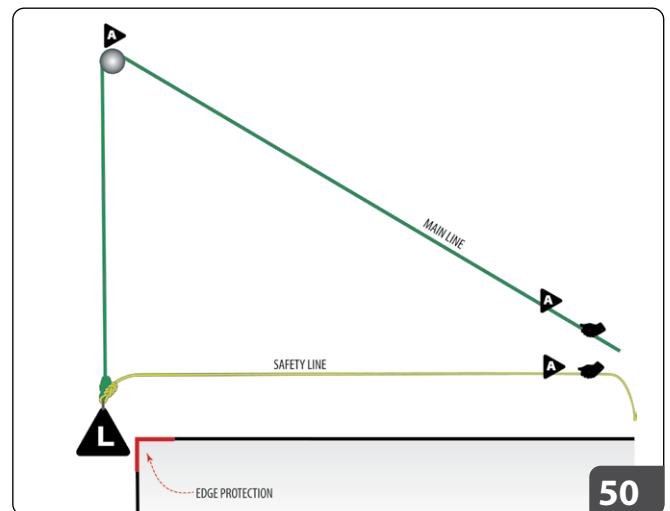

WARNING

Edge protection should always be used to protect both lines against damage and edge trauma. Failure to do so may result in line failure causing damage, injury or death.

Understanding Forces

Understanding the forces at a change of direction pulley

Most edge management tasks require the use of one or more pulleys to change the direction of the main line so it's important to understand and correctly assess loads and resultant forces.

An applied force has magnitude and direction. A change of direction pulley is subjected to two forces:

1. The weight of the load, and
2. The force required to manage that load.

The force required to manage the load will vary because of friction. The resultant force bisects the two applied forces i.e. rope/cable coming into and out of a pulley (Figure 52).

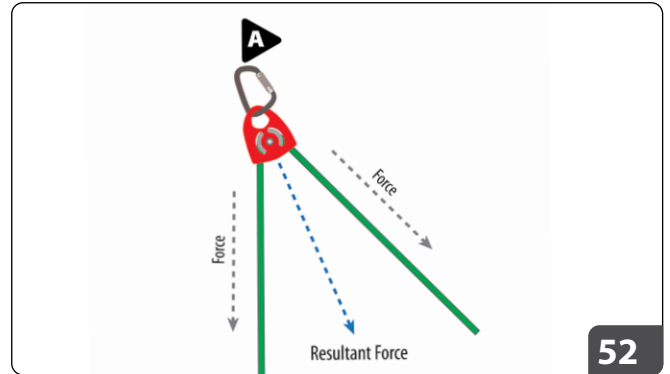

52

Understanding the forces being applied to the Arachnipod

When deployed, the Arachnipod will be subjected to resultant forces and directions. Additional rigging can be used to stabilise the Arachnipod to manage sideways forces or other situations where the tripod may become unstable.

If two people apply identical horizontal forces to a length of rope (Figure 53), the rope would remain stationary because the load forces are equal and no movement would occur.

If an Arachnipod is placed under this rope, the same rules would apply. However, because there is a change of direction in the rope, a resultant force now exists (Figure 54).

Various Arachnipod components and rigging can be used to balance the forces:

1. The legs of the Arachnipod system are generally used to balance compression forces
2. Additional rigging is used to balance tension forces, and
3. Some rigging may be used to pre-load the tension rigging to minimise movement-created rope stretch and cyclic loading.

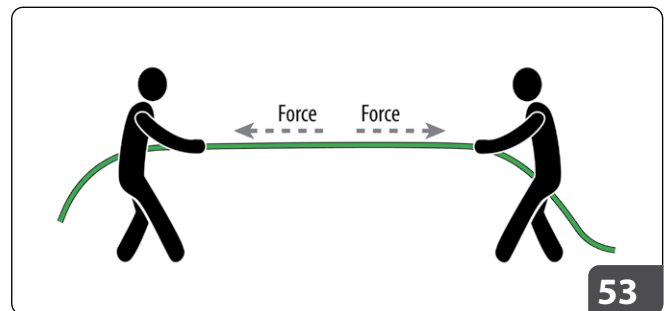

53

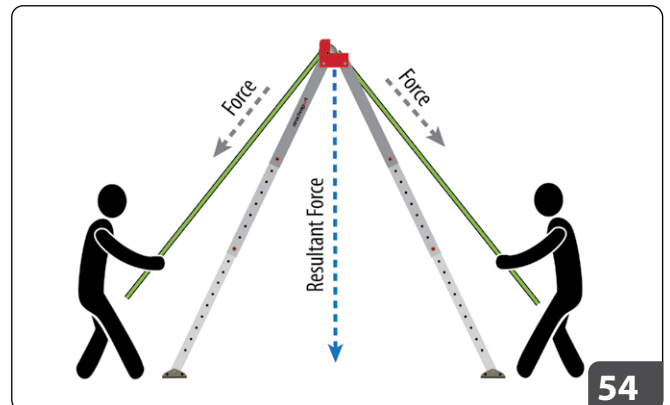

54

Anchoring the Arachnipod

The number of anchors required to stabilise the Arachnipod, safety and working lines will depend on the scenario and Arachnipod configuration.

In general, separate anchors will be required for:

1. The main line
2. The safety line
3. Edge safety lines for persons working close to an edge
4. The initial tether used to secure the Arachnipod
5. Each tension / stabilising line
6. Each pre-load line

Anchor selection and anchor rigging techniques are not within the scope of this manual.

Using an Arachnipod leg as an anchor

The Arachnipod Equipment Bracket may be used as a rated attachment point. It is designed and tested for attachment to the middle leg section.

The Equipment Bracket may be attached to the lower leg section **only** when it is used with mechanical advantage rigging. Refer to Equipment Bracket 2:1 Rigging Instructions, page 28.

Always include a change of direction at the head when an equipment bracket, fall block or winch is used as an anchor (Figure 55).

Anchoring to a leg is useful including tripod applications. When a leg is used as an anchor, the WLL is reduced to 220kg.

WARNING

- Ensure anchor points to a structure are capable of withstanding the impact force generated by a possible free fall. Attachment / anchor points must be compatible with the safety line hardware.
- Improper stabilisation and rigging of the Arachnipod can cause injury or death. Operators must be competent and trained in stabilisation techniques.

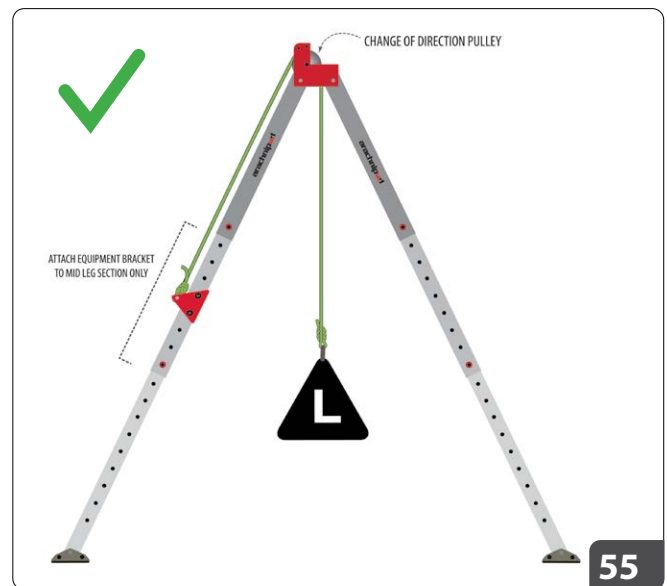

5 - STABILISING THE ARACHNIPOD

Stabilising the Arachnipod

Additional rigging may be required to stabilise the Arachnipod. The purpose is to manage sideways forces (e.g. change of direction) or other situations where the Arachnipod may become unstable.

The stabilisation examples in this section will look at resultant directions, and suggests how the stability of an edge management configuration may be managed.

TRIPOD STABILISATION

The tripod application in Figure 43 does not require additional rigging because the resultant force and direction is within the triangle formed by the feet.

The tripod application in Figure 58 and Figure 59 (top view) requires additional rigging to counteract or balance the resultant force and direction.

QUADPOD STABILISATION

The Quadpod allows for greater versatility and stability combining four legs into one system. A quad plate is used to ensure stability of the system.

The principles of stabilising a quadpod are the same as for a tripod, with the addition of an extra leg. Refer Figures 57-59.

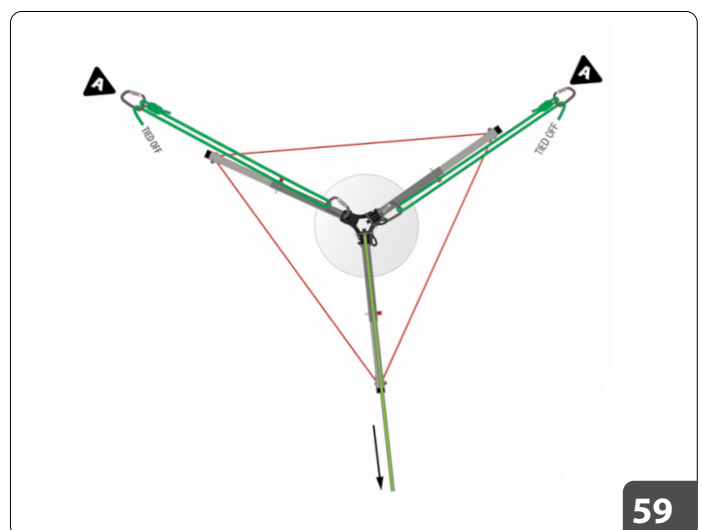
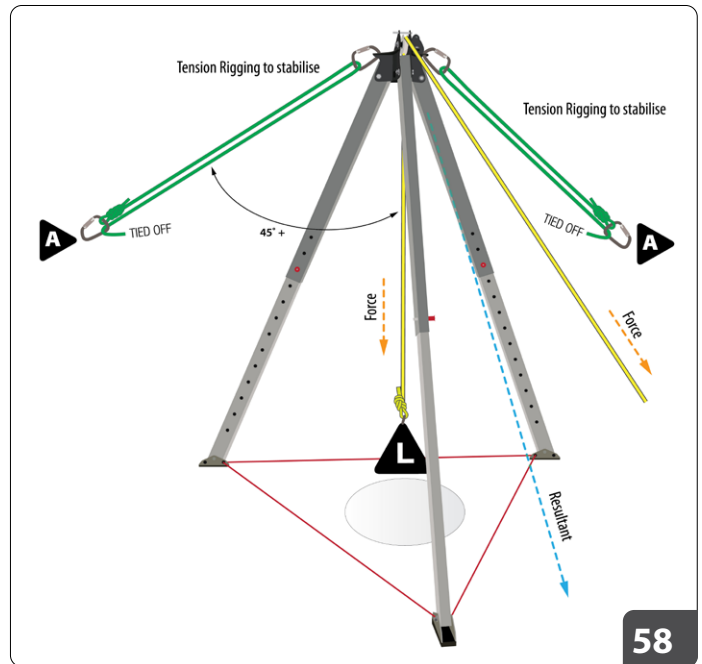
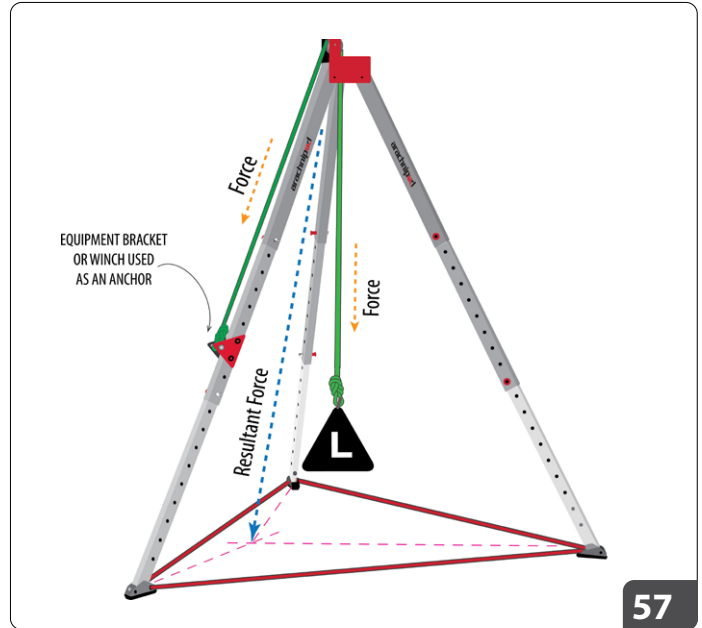

ESSENTIALS: STABILISING ARACHNIPOD

Lazy Leg TRIPOD STABILISATION

A Lazy Leg or easel leg tripod is similar to a regular tripod because it uses three legs in compression.

A Lazy Leg tripod is constructed as an A-frame, utilising a Lazy leg as the third leg. The angle and length of the Lazy Leg is set so that the resultant force and direction can be managed.

Some Lazy Leg tripods will require additional rigging to provide sufficient stabilisation and security.

If a Lazy Leg tripod is rigged so the resultant force and direction is being applied downwards and within the triangle formed by the feet, then the tripod will remain stable (Figure 60). If the load shifts closer to any given leg, then the load applied to that leg increases, but the tripod will still remain stable.

If the resultant force and direction is being applied outside of the triangle formed by the tripod feet, then the tripod will become unstable. Additional rigging will be required to provide tripod stability (Figure 61).

The length and position of the Lazy Leg may be adjusted to assist with the management of the resultant direction.

Figure 62: Top view of stabilisation for Figure 61 configuration

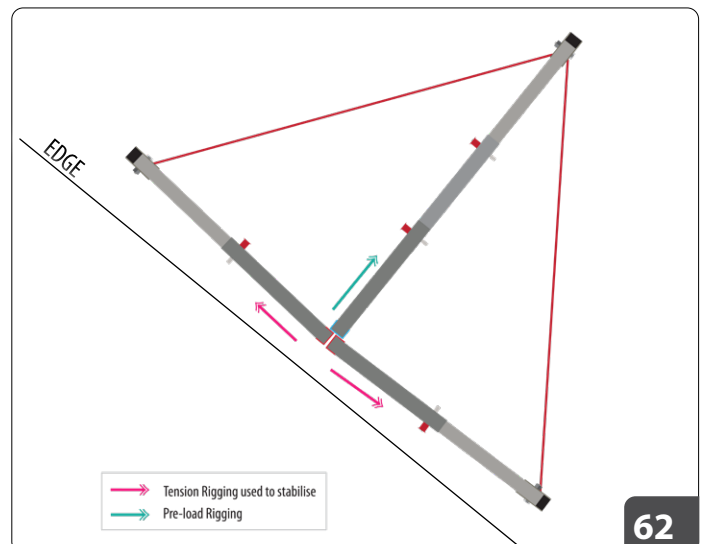
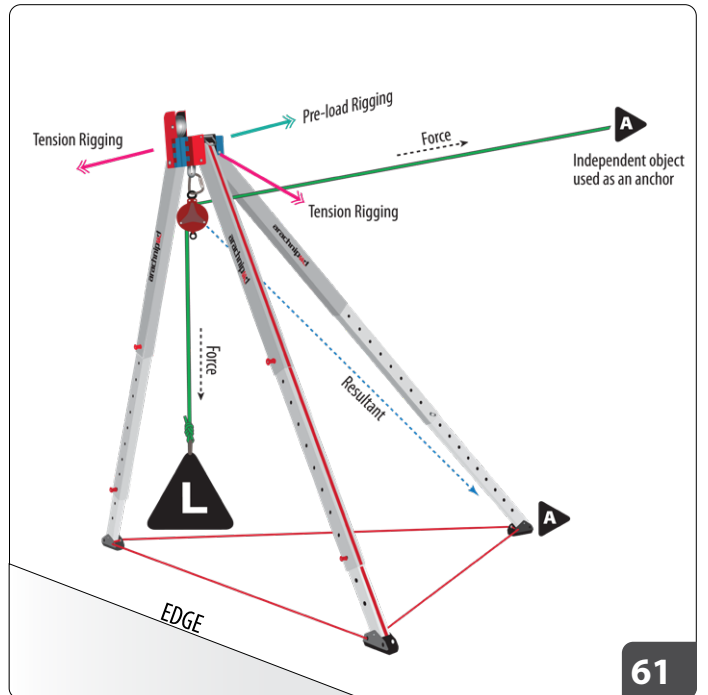
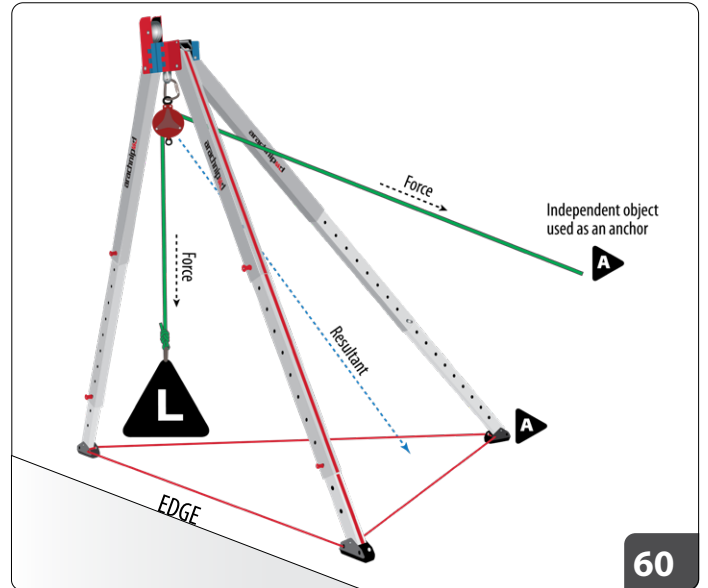

BRIDGE STABILISATION

A bridge system makes use of four legs that are all in compression. The bridge beam spans between two sets of two legs.

If the bridge is rigged in such a way that resultant force and direction remains within the rectangular footprint formed by its feet, then the bridge will remain stable. The strength of the bridge beam and the four legs balances the resultant force. If the load shifts closer to any given leg, then the load being applied to that leg is increased but the bridge will still remain stable.

Additional rigging must be used to protect against any unplanned shifts in resultant direction. Instability will occur if the resultant moves outside the bridge system's rectangular footprint.

Consideration should always be given to the stability of the feet regardless of the configuration being used.

Every change of line direction will create a resultant direction. In Figure 63 the resultant below the load is directly contributing to the stability of the bridge.

A Bridge Ratchet Strap Kit, customised for convenient use with the Arachnipod, is available for stabilising the bridge system.

A-FRAME STABILISATION

An A-Frame makes use of two legs to form two compression members. A-Frames always require rigging to provide at least one tension member. Additional rigging is used to provide two tension members, and pre-load rigging can be used to hold the A-Frame in position.

A-Frames can be constructed with Arachnipod components using three methods:

1. Standard A-Frame
2. Sideways A-Frame
3. A-Frame with Lazy Leg.

STANDARD A-FRAME STABILISATION

This method is ideal for holding span lines off an edge.

Figure 64

- Two legs are positioned at right angles to the load line.
- Tension and pre-load rigging is used to hold the A-Frame in position.

Figure 65 - Top view

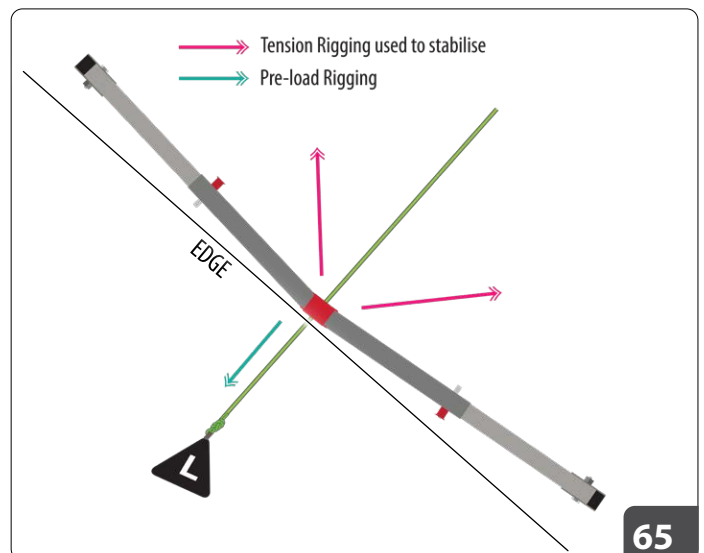
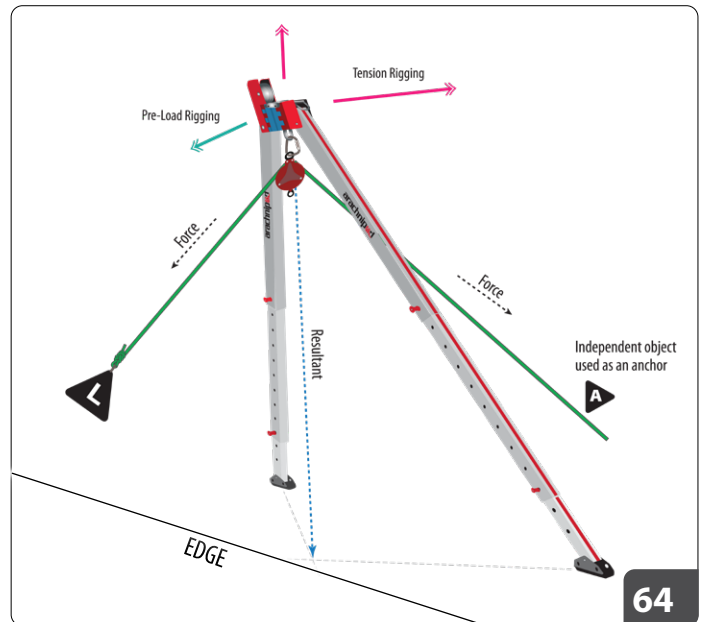
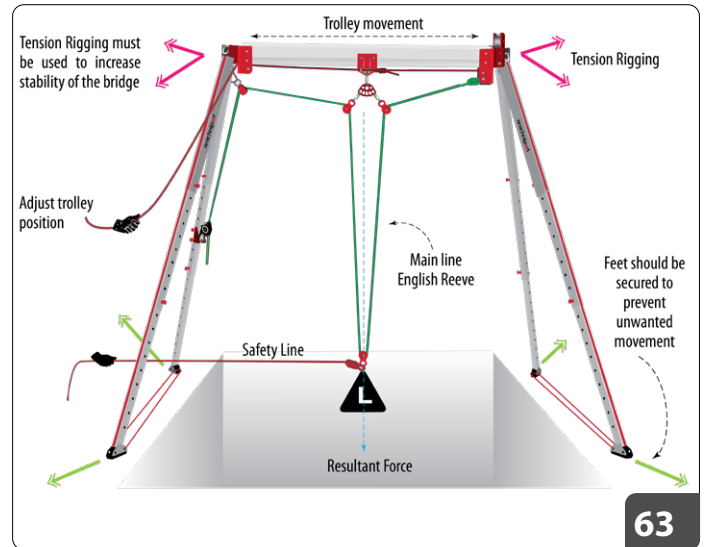

ESSENTIALS: STABILISING ARACHNIPOD

SIDEWAYS A-FRAME STABILISATION (Figure 66)

This configuration has two legs positioned close to parallel with the load line. The leg lengths and positions are set so the resultant is focused between the two legs but not in direct alignment with the legs.

The Sideways A-Frame is tilted to ensure that the resultant direction remains focused at a point that is offset from the alignment of the legs.

- If the tilt is offset to the right, then the tension rigging will need to be on the left.
- If the tilt is offset to the left, then the tension rigging will need to be on the right.
- The feet will need to be securely located or lashed into position to resist lateral movement.
- All rigging should be adjustable so tensions can be modified if and when required.

When rigging a Sideways A-Frame, the resultant forces are being applied downwards and balanced mostly by the A-Frame legs. The Sideways A-Frame should be laid over / offset by a few degrees for two reasons:

1. To provide clearance so the main line does not rub or catch against the Arachnipod
2. To ensure the rigging is clearly identified as being 'tension rigged' and 'pre-load rigged'.

Tension rigging keeps the A-Frame in position, and balances out resultant forces created by the lay or offset positioning of the Sideways A-Frame. The pre-load rigging is used to pre-load the Sideways A-Frame and hold it firmly against the ground.

The load upon the tension rigging increases as the offset is increased. Sufficient offset is required to ensure the tension rigging remains taut with consideration to any changes in load force direction during operation.

Avoid excessive offset because this places unnecessary force on the tension rigging.

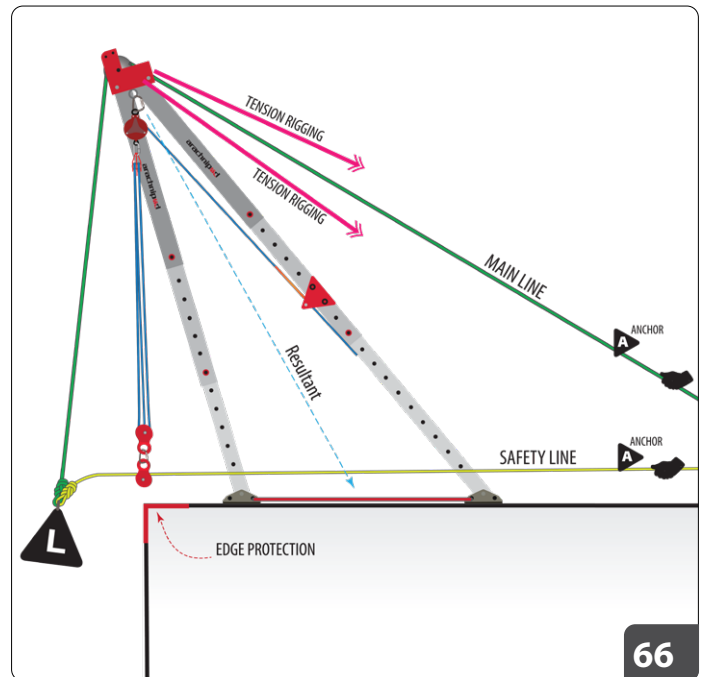

A-FRAME WITH Lazy Leg

An A-Frame with Lazy Leg (Figure 67 and 68 top view) uses two legs positioned parallel to the load line, and held in place with the Lazy Leg and rigging.

Although this method is technically a Lazy Leg tripod, it is used in a way that the Lazy Leg is only subjected to the tension that is applied by the tension rigging. Tension rigging is used to apply some pre-load force onto the Lazy Leg.

If the Lazy Leg is lashed into position with no tension rigging, then the Lazy Leg will be subjected to some of the system's tension.

Tension rigging and/or Lazy Leg is used to support the A-frame when their legs are in compression.

This method is ideal when there are no anchors available for pre-loading on the low side of the A-frame.

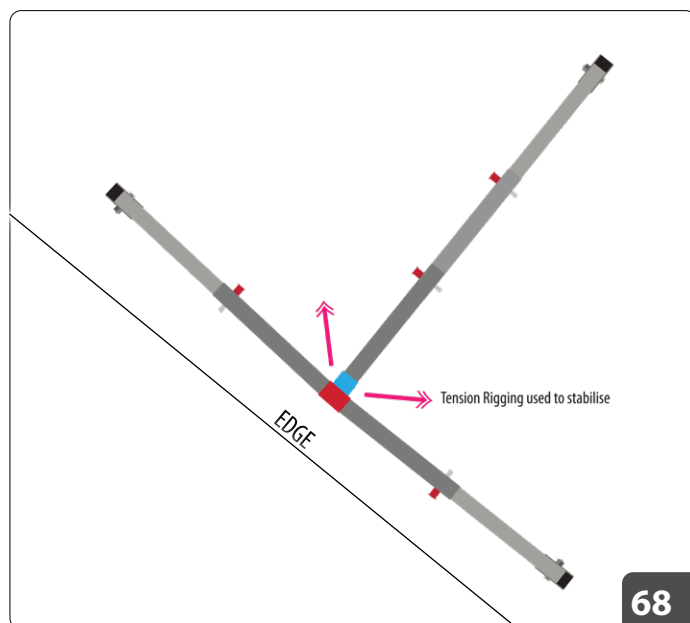
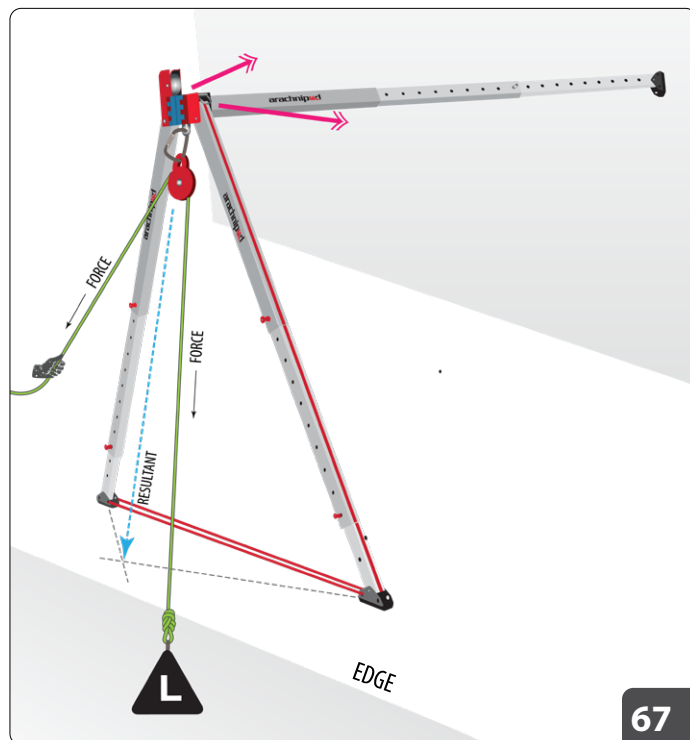

ESSENTIALS: STABILISING ARACHNIPOD

GIN POLE STABILISATION

A Gin Pole (monopole / monopod) makes use of a single leg to form the compression member.

Gin poles always require tension rigging to keep it stable and should have a minimum of three lines spaced at 120° angles. If possible, four tension lines spaced at 90° will stabilise the Gin Pole even more.

The foot should be secured to prevent movement.

The Gin Pole should be positioned and rigged so that resultant forces are applied close to the long axis of the leg (Figure 69 and 70).

Tilt or offset the Gin Pole by a few degrees off vertical in order to provide clearance for the main line from the Arachnipod leg. Offsetting the Gin Pole also enables the tension and pre-load rigging to be clearly identified.

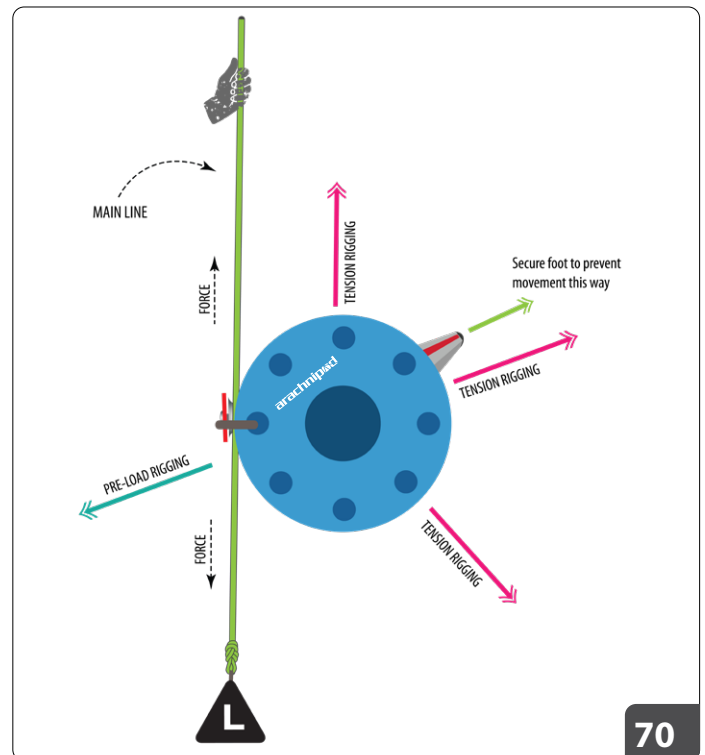
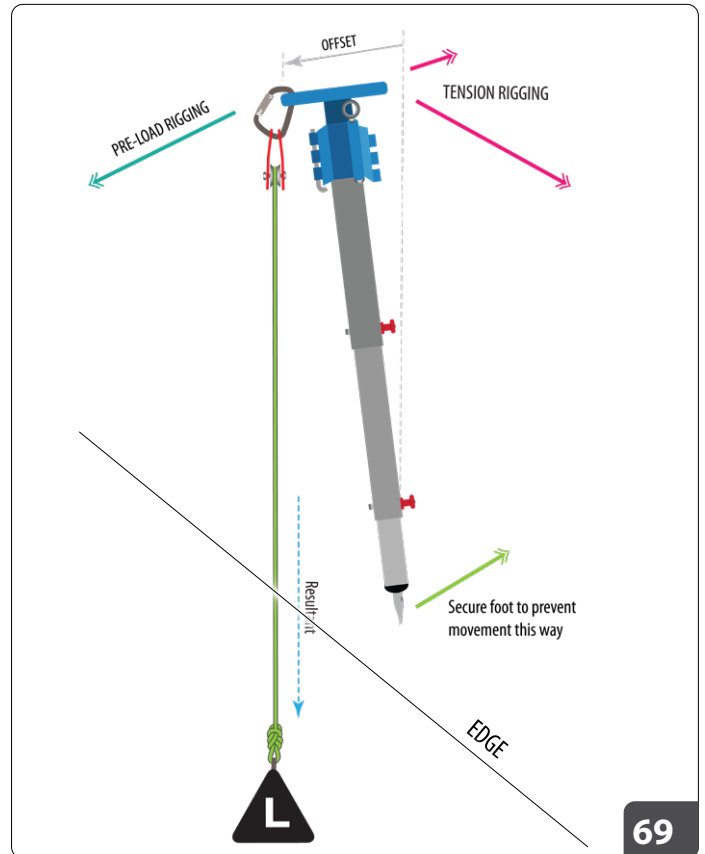

6 - INSPECTION & MAINTENANCE

6.1 Cleaning, Storage and Transportation

- Wash the Arachnipod with warm water and soft detergent.
- Rinse with clean water.
- Leave the Arachnipod to dry in a sheltered, warm, dry and ventilated area.
- Do not use additional heat sources or blowers to dry the Arachnipod.
- Avoid exposing the Arachnipod to chemicals, oils, solvents and other aggressive or corrosive materials and agents.
- Once the unit is clean and dry, store the Arachnipod in its bags and store at room temperature away from direct sunlight.
- The Arachnipod should always be protected from damage during transport. Arachnipod units are supplied in customised bags.

6.2 Inspection and Maintenance

ARACHNIPOD DISASSEMBLY

The disassembly and rigging process for the Arachnipod depends upon a number of factors including:

- The type of Arachnipod kit
- The configuration that is used.

It is recommend that two or more people work together to disassemble the Arachnipod components as follows:

Step 1: Preparation

- Establish a working area where the Arachnipod components can be laid out
- A working area is a location that is safe, away from fall, slip and other hazards that would impede the inspection process
- A clean tarp or work area is beneficial for the inspection process

Step 2: Legs

- Lay the unit down on the work/ inspection area
- Remove the Qik Link pins from each of the heads (Fig 71)
- Repeat this process for any other legs to ensure all the legs are independent to each other

NOTICE

If the stoppers are missing or do not work, the leg sections can separate completely from one another. Any legs with missing or damaged stoppers must be returned to Ferno or an authorised repair agent for repair.

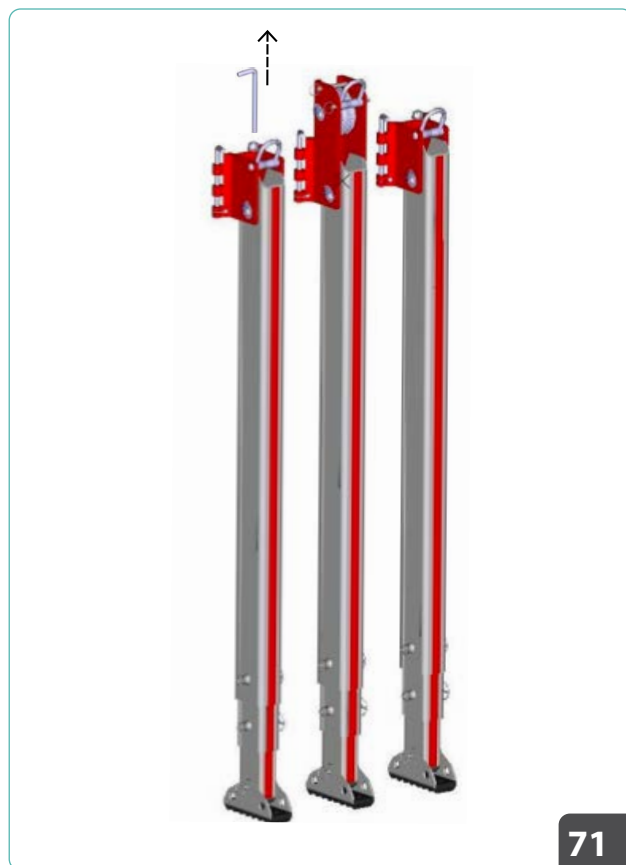

71

LEG INSPECTION

Extend and Inspection of Legs and Pins

1. Remove both leg pins from the legs and extend the legs to their maximum extension. During the process of extending the legs, ensure the legs move smoothly without any snagging.
2. When legs are at maximum extension, ensure the legs do not come apart and are stopped by the internal leg stopper.
3. Inspect the legs for damage, deep gouging, deformation and straightness. If there are any signs of bending, deformation or deep gouging the leg must be replaced.
4. Check each leg pin hole on the leg (Fig 72), looking for damage, deformation, gouging and lower deep indentations on the pin area. If deep (more than 0.5mm) indents are evident, this may be an indication that the leg has been subjected to overloading and should be removed from service.

Leg Pin Assembly Inspection

1. Inspect the leg pin ensuring smooth operation. When button is depressed, small ball stoppers on other end of pin should release.
2. Inspect the cable that attaches the leg pin to the leg. If the cable is damaged, contact service agent for repair.



Arachnipod Ball Lock Leg Pin #68-0054

Labels

Red labels are adhered to the outside face of each leg. The middle and lower leg have alpha and numeric markings at each hole position to allow all legs to be easily set to the same height (eg B-3). Check all labels are present and legible. If the red alpha-numeric labels are damaged contact service agent for repair.



Arachnipod Label - Reflective Silver #51-0059



WARNING

Do not place fingers in leg pin holes. If telescopic leg sections slide unexpectedly, it can cause severe injury to fingers.



INSPECTING THE HEADS OF EACH LEG

Standard Leg (Fig 73)

1. Remove the Qik Link pin from the leg and inspect the pin for any damage or deformation. Inspect the cable on the Qik Link pin that holds the pin on to the head for damage. In the event of damage or deformation, contact service agent for repair.
2. Inspect the hinge attachment points (hinge cut-outs) and ensure they are not damaged and that the Qik Link pin inserts easily into the hinge cut-outs. Ensure the Qik Link pin locks into the spring keeper and that the Qik Link pin is held firmly into place once inserted into the head attachment point.
3. Inspect the rated load attachment point (eyebolt) and ensure it can swivel 360° and that the top holding nut weld is intact and has not been tampered with. Ensure the eye is not deformed and there is no evidence that the attachment point has been overloaded. In the event of overloading or deformation the leg must be permanently removed from service.
4. Inspect Stabilisation Attachment Point (D-shackle) for deformation or damage. In the event of deformation or damage, replace the D-shackle.
5. Ensure head moves and swivels easily on the leg and there is no binding up of the movement.
6. Ensure the Head/ Leg bolt is tight and secure. If the head/ leg connecting bolt is loose, remove the bolt and apply Loctite® 7262 thread locking compound to the threads and re-tighten the bolt. Be careful not to cross-thread the bolts as the product will become unsafe, dramatically reduce the WLL and be dangerous to use. If cross threaded, the unit must be sent back to Ferno Australia.
7. Inspect the entire head for damage, gouging, deformation and indentations. Normal wear and tear is acceptable. However if obvious damage is noticeable, return to Ferno or an authorised agent for repair or replace the entire leg unit.
8. Inspect the load rating labels on either the head or leg and ensure all the information is legible.



73

INSPECTION & MAINTENANCE

Pulley Leg (Fig 74)

1. Follow all the inspection procedures as laid down for the Standard Leg.
2. Inspect the pulley and ensure that the pulley rotates freely and there is no binding up or resistance on the bearings of the pulley. Inspect the grooves of the pulley and ensure there is no damage or sharp edges within the sheave.
3. Ensure the two detent pins are fully operational and insert easily into the holes of the head. If they show signs of rust, lubricate with a Teflon based spray lubricant. The pulley has been designed to accommodate up to 13mm fibre rope as well as up to 8mm steel/ stainless steel wire rope cable.
4. The stabilisation attachment point (D-shackle) is removable. It is attached with the two detent pins via a cable. Ensure the cable is intact and free from damage. If any parts are damaged, contact service agent for repair.

 **SS Detent Pin** - 3/8" dia x 3" #68-0036

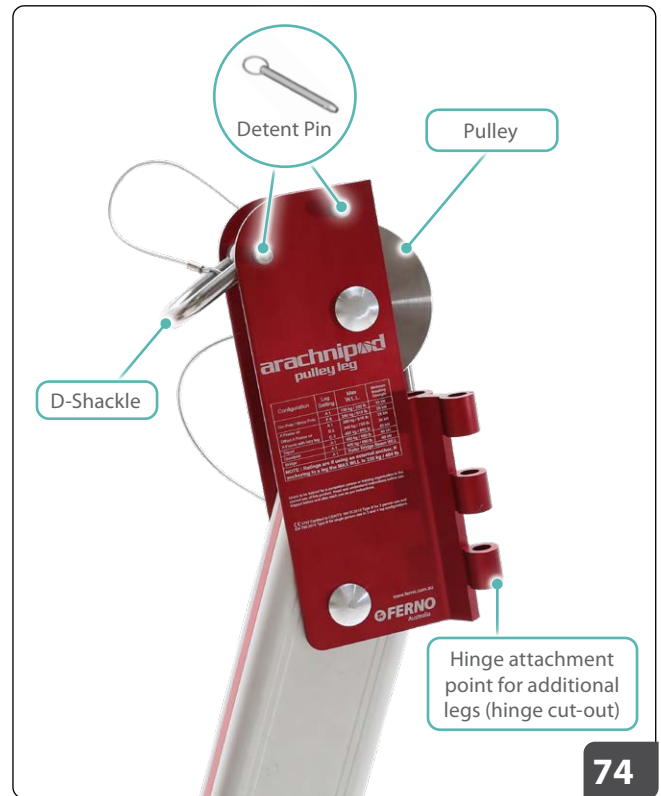

74

Lazy Leg (Fig 75)

1. Follow all the inspection procedures as laid down for the Standard Leg.
2. The Lazy Leg is coloured blue for easy identification. It has a pivot range of 180°. Remove the Detent Pin and Stabilisation Attachment Point (D-shackle) from the head. If a Lazy Leg Adaptor is present, remove it. Refer to Arachnipod Operators' Instructions regarding the Lazy Leg Adaptor application and use.
3. Ensure the Lazy Leg Head can pivot 180° and that there is no binding up or stiffness in the pivot action.
4. The stabilisation attachment point (D-shackle) is removable. It is attached with the Detent Pin via a cable. Ensure the cable is intact and free from damage. If any parts are damaged, replace with the following parts:

 **SS detent pin** 3/8" dia x 3" #68-0036

NOTE: There are two versions of the Lazy Leg

- Lazy Leg (no eye bolt) - manufactured up to 23 August 2020
- Lazy Leg 2 (with eye bolt) - manufactured from 24 August 2020

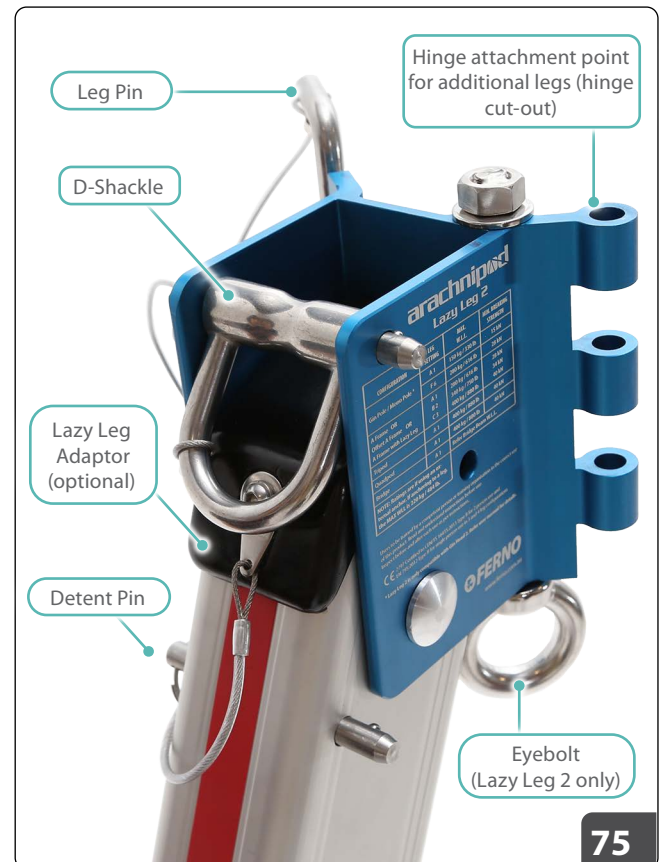

75

FOOT INSPECTION

Standard Foot (Fig 76)

Standard feet are supplied with all legs.

1. Remove the Detent Pin from the leg and inspect the Detent Pin and cable attachment. Replace the cable if it is damaged with part:

 **SS Detent Pin** - 3/8" dia x 2.5" #68-0035

2. Inspect the foot ensuring the polyurethane plastic tread is not damaged.
3. Inspect the foot and lashing holes for deformation, damage and sharp edges. If any of these are evident, replace the foot with part:

 **Arachnipod foot with tread** (Standard Foot 2) #90-0472

Spike Foot (Fig 77)

The spike end of the reversible Spike Foot can be used for point loading and ground penetration applications. The rounded end of the foot is used to avoid penetrating the supporting surface. A stainless steel tip is incorporated to extend the service life of the Spike Foot. The Spike Foot inserts in to the foot socket on the leg end and is held in place with a Detent Pin.

1. Inspect the Spike Foot for deformation, damage and sharp edges. If the Spike Foot's stainless steel tip is deformed and damaged, it can be replaced by unscrewing the tip and replacing it with a new tip. Prior to inserting the new tip, place Loctite® 7262 thread-locking compound on to the thread and then tighten.

 **Spike foot tip** #22-1004
Spike foot with tip #90-0120

2. Insert the Spike Foot into the foot socket on the leg, ensuring the Spike Foot slides smoothly into the socket. Align the Spike Foot detent pin hole and insert the detent pin through these holes. The insertion and locking process should be smooth and easy.
3. Remove Spike Foot and repeat Step 2, reversing the foot 180°.
4. Remove the detent pin and spike foot from the leg and repeat this process for all the spike feet.

Soft Ground Shoe (Fig 78)

The Soft Ground shoe is used in conjunction with the Spike Foot and is fitted to the leg over the Spike Foot.

1. Inspect each Soft Ground shoe ensuring there is no deformation or cracking present.
2. Insert a Spike Foot into the leg prior to checking the operation of the Soft Ground Shoe.
3. Place the Soft Ground Shoe on to the curved part of the foot adaptor plug on the bottom of the leg, ensuring the Soft Ground Shoe moves freely and stays in place once inserted on to the leg.

 **Arachnipod soft ground disc** #34-0032

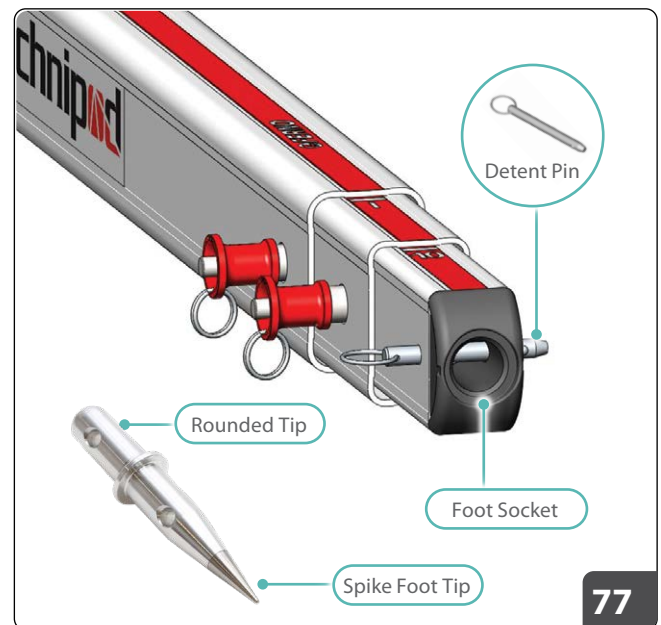
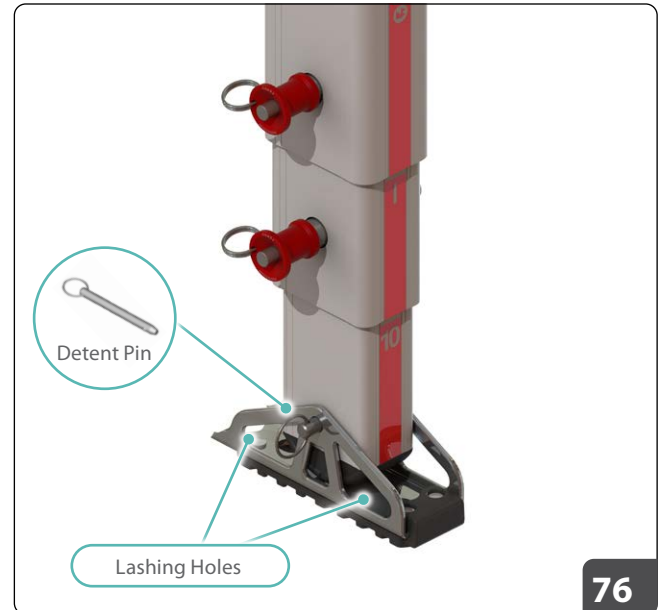

INSPECTION & MAINTENANCE

HOLD DOWN STAKE INSPECTION (Fig 79)

A Hold Down Stake can be used to secure a Standard Foot to the ground. The Foot Locating Spike lines up with one of the holes in a Standard Foot.

1. Inspect the Hold Down Stake and ensure there is no deformation or damage. Ensure the welding on the component is intact and there is no cracking on the welded areas.
2. Ensure the Foot Locating Spike feeds easily through Standard Foot hole as illustrated in Fig 12.



Arachnipod Soft Ground Stake #16-1046-0

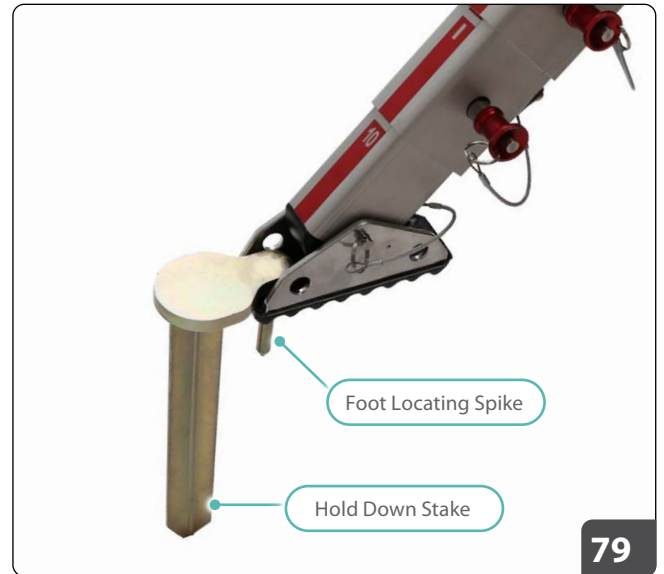

GIN HEAD INSPECTION (Fig 80 and 81)

The Gin Head is used with a Lazy Leg to form a Gin Pole. There are two versions of the Gin Head. Both versions are installed and perform the same way.

1. Inspect the Gin Head for any damage, deformation and sharp edges.
2. Insert the Gin Head into the Lazy Leg ensuring there is no binding or resistance during insertion.
3. Place the Lazy Leg Detent Pin into the Lazy Leg and ensure the pin moves smoothly through the Detent Pin hole of the Gin Head and Lazy Leg.

NOTE: Gin Head 2 (from 24 August 2020) has a slightly different profile and hollowed head to the original Gin Head. The original Gin Head is compatible with only the original Lazy Leg whereas Gin Head 2 is compatible with Lazy Leg 2 and the original Lazy Leg.



Gin Head Label #51-0063

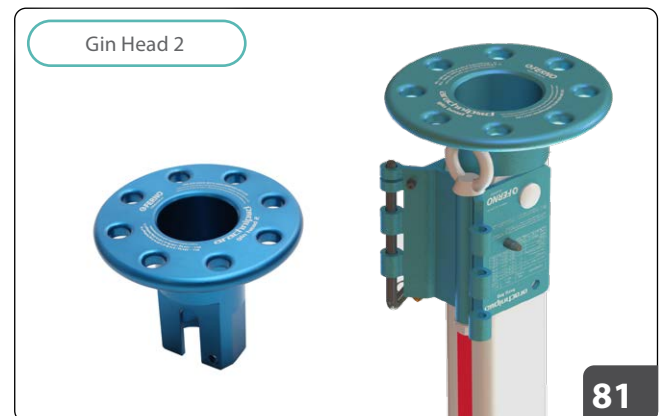

RIGGING PLATE INSPECTION (Fig 82)

A rigging plate is used when two legs are connected as an A-Frame.

1. Inspect Rigging Plate and ensure there is no deformation, damage or sharp edges.



Arachnipod rigging plate #26-0007-0

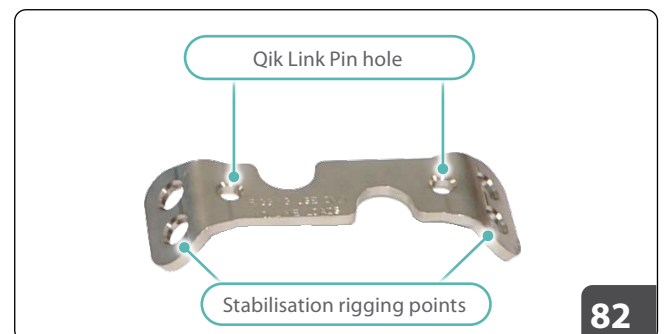

EQUIPMENT BRACKET (Fig 83)

The Equipment Bracket must only be used when attached to the mid section of the telescopic leg.

1. Remove leg pins from Equipment Bracket.
2. Inspect cables that attach the pins and ensure cables are not damaged. If there is any damage, replace the cables.
3. Ensure the bolts on the attachment point are tight and secure. If either of the bolts are loose, remove the bolt and apply Loctite® 7262 thread locking compound to the threads and re-tighten the bolt. **Be careful not to cross-thread the bolts.** If cross threaded, the unit must be sent back to Ferno Australia.
4. Ensure the etching on the Equipment Bracket is readable and that no writing/information is obscured.

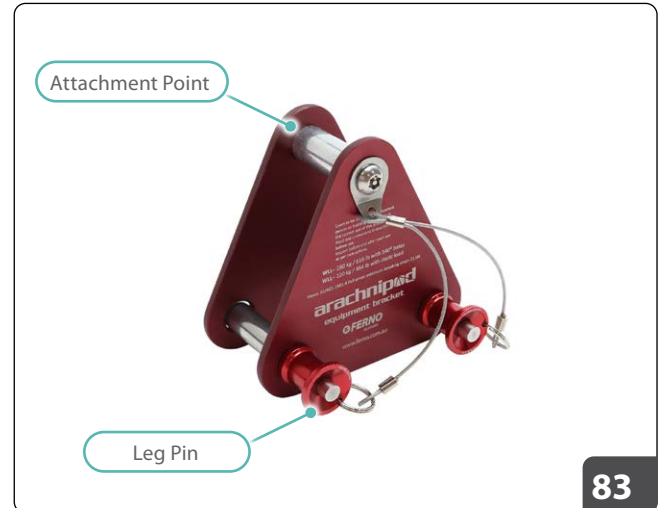

83

WARNING

Do not cross-thread bolts. Using cross-threaded bolts will dramatically reduce the WLL of the Equipment Bracket, rendering it unsafe and unpredictable to use. The unit must be removed from service for further inspection.



Arachnipod Ball Lock leg Pin #68-0054

REVERSE HEAD (Fig 84)

1. Remove the Qik Link pin from the head and inspect the pin for any damage or deformation. Inspect the cable on the Qik Link pin that holds the pin on the head for damage.
2. Inspect the attachment points (hinge cut-outs) and ensure they are not damaged and that the Qik Link pin inserts easily into the hinge cut-outs. Ensure the Qik Link pin locks into the spring keeper and the pin is held firmly into place once inserted into the head attachment point.
3. Inspect the entire head and D-shackle for damage and indentations. Normal wear and tear is acceptable. If obvious damage is noticed, replace the entire unit.
4. Ensure the D-shackle centre bolt is tight and the actual D-shackle pivots freely on the bolt. If the bolt and nut are loose, re-tighten Nylock nut on the side of the Head.
5. Inspect the load rating label on the Head and ensure all the information is legible.



84

BRIDGE BEAM & TROLLEY INSPECTION

Bridge Beams are available in 2 m, 3m and 4m lengths.

Bridge Beam (Fig 85)

1. Lay the Bridge Beam on a flat surface and ensure there is no bending or deformation of the beam. Ensure there are no sharp edges, deep indentations or cracks within the Bridge Beam.
2. Inspect each Head attachment point ensuring the Qik Link pins are aligned and they insert smoothly into the cut-out sections. Ensure the Qik Link pins bed securely into Spring Keeper.
3. Ensure all the bolts that hold the head attachment points on to the beam are tight and fastened. If any bolts are loose, re-tighten them.
4. Inspect the Trolley rope. The rope should be tied to the eye bolts on the Bridge Trolley with Yosemite bowline knots. Check the knots are secure and ensure there is no damage, evidence of chemical contamination or abrasion of the rope. If any of these are present, the rope must be replaced. It is important to replace the rope with 8mm kernmantle rope as supplied by Ferno Australia.
5. Inspect the pulleys through which the trolley guide rope runs at each end of the Bridge. Ensure that pulleys move freely and do not bind up. If the bearings need replacing, return the unit to Ferno or an authorised Ferno repair agent.



Bridge Beam Trolley (Fig 86)

1. Inspect the Bridge Beam Trolley ensuring there is no deformation, damage or rust on the trolley.
2. Check all the bolts on the Bridge Beam Trolley are fastened and secure.
3. Ensure the Trolley or bearings on the Bridge Beam Trolley are not corroded and that the bearings rotate freely without any resistance. If the bearings need replacing, return the unit to Ferno or an authorised Ferno repair agent.
4. Check the trolley has the SWL/ WLL label present. If illegible or missing, replace the label with:



Bridge Trolley Label, 250kg WLL #51-0069



ARACHNIPOD WINCH INSPECTION (Fig 87)

The Winch is supplied with a bracket to mount it to the mid-section of any Arachnipod supporting leg. It is rated to 220kg/ 485lb.

Thorough Inspection of Arachnipod Winch

1. Clean if required and visually inspect the winch and mount bracket for physical damage and chemical contamination.
2. Check for cracks, corrosion, deformation, abrasions and any other damage.
3. Check the label is in good condition and legible. Replace if necessary.



Arachnipod Winch Label #51-0066

NOTE: When replacing a label, the Winch serial number must be transferred to the new label and recorded in the equipment log.

Thorough Inspection of Winch Wire Rope Cable

1. Unwind the drum until the cable is completely unwound.
2. Visually inspect the entire length of the wire rope by passing the wire rope through gloved hands, flexing the cable every few inches to expose any broken strands of wires.
3. Inspect for any degradation or damage. Especially look for cuts, local surface abrasion, signs of chemical contamination, corrosion (rust), discolouration and glazing. Special attention should be paid to the wire rope around the swaged eye.
4. The cable has a red indicator to alert users when there is only 1 m of cable left on the drum. Check this red heat shrink marker is still present on the cable. It should be approximately 1m from the drum.
5. Ensure wire rope end is securely fastened to the drum of winch. Check that the wire rope is threaded through the hole within the bolt and that the nut is securely fastened.
6. Check there are three (3) wraps of cable secured together with a swage, and that the swage is tight.
7. The cable should be replaced if there are six or more randomly broken wires in one lay, or three or more broken wires in one strand in one lay. If the cable needs replacing, return the complete winch to Ferno or a Ferno authorised repair agent.

Winch Notes

- **Lay** is a length of wire rope that it takes for one strand to complete one revolution or twist along the cable.
- **Strand** is a larger group of wires that make up a cable.
- The cable should be replaced if there are any broken wires within 25mm (1") of the metal swages at either end of the cable.
- The cable assembly should be replaced if the cable is severely kinked, cut, crushed, burnt, corroded or suffering any other type of damage.

Thorough Inspection Function Test

1. Extract 600mm to 1000mm of rope
2. Apply 50kg weight to the rope. The rope should lock off with no slippage.
3. Wind the winch making sure that the gears aren't slipping.

Lubrication on the Winch

The only lubrication to be used on the winch is an aerosol spray chain lube. This should only be applied to the gears.

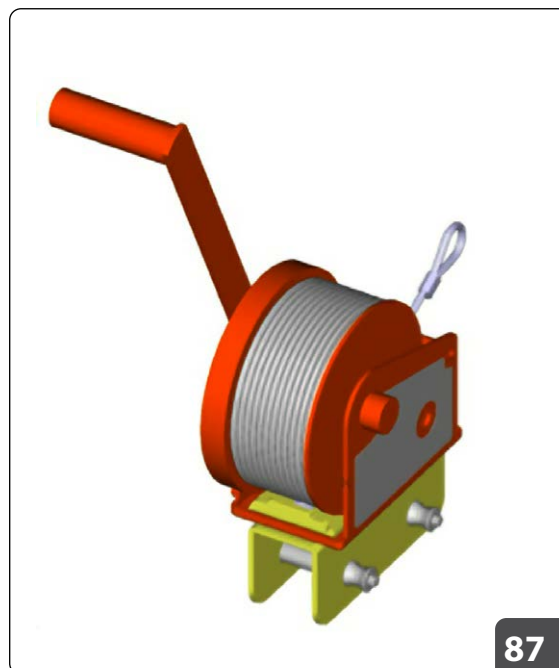

ARACHNIPOD KIT RECORDS

Each Arachnipod Kit is assigned a Kit Number. This is one collective number recorded on Ferno Australia's database, which references all individual serial numbers contained within the Arachnipod Kit.

A kit contains more than one item with a serial number. It can range from a tripod, or a tripod plus accessories to a full Total Edge Management System (TEMS) Kit. The Kit Number is found next to the serial number on ONE of the Standard Legs contained within the kit. Record this number in the space below, along with all the individual serial numbers for your own reference. Photocopy this page, or download additional copies of this form from Ferno Australia's website: www.ferno.com.au

Kit Number:	Date Purchased:		
	Date Commissioned into Service:		
Tick type of Kit Purchased:	<input type="checkbox"/> Standard Tripod	<input type="checkbox"/> Advantage Tripod	<input type="checkbox"/> Quadpod
	<input type="checkbox"/> Standard Bridge	<input type="checkbox"/> Advantage Plus Kit	<input type="checkbox"/> TEMS Kit
	<input type="checkbox"/> Lazy Leg Kit	<input type="checkbox"/> Lazy Leg Extension Kit	<input type="checkbox"/> Bridge Kit

Record serial numbers and commission dates of individual kit components below.

ITEM		SERIAL NUMBER	COMMISSIONED DATE
TRIPOD	Leg 1 / Type:		
	Leg 2 / Type:		
	Leg 3 / Type:		
Additional Leg			
Bridge			
Reverse Head			
Fall Arrest Block			
Winch			
Lazy Leg Extender: Head Assembly			
Lazy Leg Extender: Plate Assembly			

REGULAR & ANNUAL INSPECTIONS

- The unit must be inspected before and after every use by the competent person/s using the equipment.
- Additionally, the Arachnipod must be inspected by a competent, instructed, accredited person at least once a year to ensure the unit is fully functional. Details of this annual inspection should be recorded using the Inspection Record Form below.
- Please photocopy or download additional copies of this Inspection Record Form from www.ferno.com.au

INSPECTION RECORD		<input type="checkbox"/> Routine Inspection	<input type="checkbox"/> Annual Inspection
Arachnipod Model	Kit #	Date of Manufacture	Agency/Unit
<input type="checkbox"/> Tripod	<input type="checkbox"/> Lazy Leg	<input type="checkbox"/> Spare Legs	<input type="checkbox"/> Bridge
<input type="checkbox"/> Reverse Head	<input type="checkbox"/> Type 3 Fall Arrest Block	<input type="checkbox"/> Winch	<input type="checkbox"/> Accessory Kit
<input type="checkbox"/> Lazy Leg Extender Kit	<input type="checkbox"/> Other: _____		
Detail any items requiring maintenance and action taken. Use additional forms if required.			
Item & Serial Number	Maintenance / Action Taken	Parts Replaced	
Inspected by (Full Name)		Inspection Date (DD/MM/YYYY)	
Signature		Next Inspection Due (DD/MM/YYYY)	

ARACHNIPOD SPECIFICATIONS

7 - DETAILED SPECIFICATIONS & PARTS

Dimensions and Weight

ARACHNIPOD COMPONENT	STORAGE	MAX. LENGTH	WEIGHT
Standard Leg / Lazy Leg	1420mm / 5 "	3050mm / 120 "	8.6kg / 19lb
Pulley Leg	1550mm / 6 "	3150mm / 124 "	10kg / 22lb
Standard Tripod	370mm x 130mm x 1550mm 14.6" x 5.1" x 61"	3150mm / 124 "	27.2kg / 60lb
Tripod Bag (empty)	380mm x 150mm x 1600mm 15.7" x 7.9" x 26"	not applicable	6.5kg / 14.3lb
Full Accessory Kit (full)	400mm x 20mm x 660mm 15.7" x 7.9" x 26"	not applicable	19kg / 41.8lb
2m Bridge	290mm x 150mm x 2070mm 11.5" x 6" x 81.5"	not applicable	21kg / 46.2lb
2m Bridge Kit	300mm x 160mm x 2150mm 11.8" x 6.3" x 84.7"	not applicable	40kg / 88lb

Working Load Limits

The typical weight of a single person load ranges from 80kg to 120kg (176lb to 265lb) depending on a number of factors. The WLL of the Arachnipod exceeds this load range in all configurations.

The typical weight of a rescue load ranges from 200kg to 280kg (440lb to 265lb) depending upon a number of factors. The Arachnipod offers many configurations that match or exceed the 280kg load with only a few exceptions.

NOTE: Throughout this manual 1lb (pound) = 0.453kg and 1kg = 2.2lb

CONFIGURATION	LEG SETTING	WLL	MBS	WLL
		External Anchor Point	(Min. Breaking Strength)	Load Anchored to Leg
Gin / Mono Pole at 2050mm extension	F-6	280kg / 616lb	28kN	not applicable
Gin / Mono Pole at 3050mm full extension	A-1	150kg / 330lb	15kN	not applicable
A-Frame <i>or</i>	A-1	280kg / 616lb	28kN	
Offset A-Frame <i>or</i>	B-2	340kg / 784lb	34kN	220kg / 485lb
A-Frame with Lazy Leg	C-3	400kg / 880lb	40kN	
Tripod and Quadpod	A-1	400kg / 880lb	40kN	220kg / 485lb
Handrail Monopole	F-6	280kg / 616lb	28kN	220kg / 485lb
Bridge Beam 2000mm span* at middle of beam	A-1	280kg / 616lb	28kN	220kg / 485lb
Bridge Beam 3000mm span* at middle of beam	A-1	230kg / 506lb	23kN	220kg / 485lb
Bridge Beam 4000mm span* at middle of beam	A-1	190kg / 418lb	19kN	190kg / 418lb
Any span** at end of beam	A-1	280kg / 616lb	19kN	

NOTE: * When a Strongbac is fitted to a bridge beam, its WLL is 280kg / 616lb at any length up to 6000mm / 236"

* The Bridge trolley WLL is 250kg / 550lb (ultimate strength 24.5kN)

**The Bridge beam MBS will differ depending on where the load is positioned along the beam. On a 2m bridge beam, the safety factors reduce from 10:1 to <7:1 as the trolley moves from the centre to the end of the beam.

Non-metallic Components

PART	MATERIAL	PART	MATERIAL
Standard foot tread	Thermoplastic Elastomer	Leg Stopper	Polyurethane
Foot socket	Polyurethane	Soft Ground Shoe	Polyurethane
Lazy Leg Adapter Plug	Polyurethane	Lazy Leg Extender Mouldings	Polyurethane
Bridge Pulley Mouldings	Polyurethane	Pulley Head Pulley Spacers	Acetal
Step Spacers	Acetal	Bridge Pulley Spacer	Acetal
Lower Leg Stopper	Acetal	Leg Bumper	Rubber

Arachnipod Core Kits

ARACHNIPOD KIT	CODE	KIT CONTENTS / INCLUSIONS						
		Standard Leg	Pulley Leg	Lazy Leg Leg	Rope Tether	Storage Bag	Bridge 2, 3 or 4 m	Accessories
Standard Tripod	APOD-STD	2	1	-	1	1	-	
Advantage Tripod	APOD-ADV	1	1	1	1	1	-	• Lazy Leg Adaptor
Quadpod	APOD-QUAD	2	2	-	1	2	-	• Quad Plate
Standard Bridge	APOD-S*B	3	1	-	2	2	1	• Quad Plate
Advantage Plus Kit	APOD-ADV+	1	1	1	1	1	-	• Lazy Leg Adaptor • Advantage Accessory Kit
TEMS* Kit	APOD-TEMS	2	1	1	2	3	1	• Lazy Leg Adaptor • Full Accessory Kit

* Total Edge Management System

Arachnipod Expansion Kits

Expansion Kits are pre-assembled components, each designed to expand the capabilities of your current Arachnipod

PART NUMBER	ARACHNIPOD PART NAME	INCLUSIONS
APOD-AKIT	Arachnipod Full Accessory Kit	For kit contents, refer to Accessory Kits and Contents table
APOD-ADV AKIT	Advantage Accessory Kit	For kit contents, refer to Accessory Kits and Contents table
APOD-LLK	Lazy Leg Kit	Lazy Leg, Reverse Head, Lazy Leg Adaptor Plug, Quad Plate and Lazy Leg Bag
APOD-EKLL	Lazy Leg Extension Kit	Lazy Leg Extender Plate Assembly and Lazy Leg Extender Head
APOD-BR2	2m Bridge Kit	2m Bridge, a spare Standard leg, Foot Tether and 2m Bridge Bag
APOD-BR3	3m Bridge Kit	3m Bridge, a spare Standard leg, Foot Tether and 3m Bridge Bag
APOD-BR4	4m Bridge Kit	4m Bridge, a spare Standard leg, Foot Tether and 4m Bridge Bag
APOD-BRS	Bridge Ratchet Strap Kit	2 each: 15 m Ratchet Straps, 1200mm Round Slings, 2500mm Snake Slings and 2500mm Round Slings. 1 x Ferno Grab Bag

Accessory Kits and Contents

QUANTITY	ADVANTAGE ACCESSORY KIT (APOD-ADV AKIT)
1	Advantage Accessory Bag
1	Rigging Plate
3	Spike Feet
1	Quad Plate
1	Reverse Head
1	Gin Head

QUANTITY	FULL ACCESSORY KIT (APOD-AKIT)
1	Full Accessory Kit Bag
1	Rigging Plate
4	Spike Feet
1	Quad Plate
1	Reverse Head
1	Gin Head
4	Soft Ground Shoes
4	Hold Down Stakes
2	Steps
1	Equipment Bracket
2	Spare Qik Link Head Pins
1	Spare Leg Pin
2	Spare Detent Pins
8	M12 Tru-Bolts
2	M12 Masonry Drill Bit

ARACHNIPOD KITS & PARTS

Arachnipod Parts List

PART NUMBER	ARACHNIPOD PART NAME
	LEGS
90-0108	Standard Leg
90-0110	Pulley Leg
90-0114	Lazy Leg
	FEET
90-0472	Standard Foot with Tread
90-0120	Spike Foot with Tip
22-1004	Spike Foot Tip only
34-0032	Soft Ground Shoes
16-1046-0	Hold Down / Soft Ground Stake
68-0041	M12 Tru-bolts
42-1019	Foot Tether & Rope Grab
	ACCESSORIES
APOD-LLA	Lazy Leg Adaptor
07-1027-0	Quad Plate
90-0121	Reverse Head
03-1037-0	Gin Head
26-0007-0	Rigging Plate
07-1026-0	Step
90-0119	Equipment Bracket
APOD-FAB	Fall Arrest Block Bracket (fits SALA or similar)
90-0449	Fall Arrest Block Bracket (fits IKAR or similar)
	WINCH & FALL ARRESTOR KITS
APOD-W10	10 m Winch & Mount - 6mm cable
APOD-W20	20 m Winch & Mount - 6mm cable
APOD-W25	25 m Winch & Mount - 6mm cable
APOD-FA	15 m Type 3 Fall Arrestor & Mount

PART NUMBER	ARACHNIPOD PART NAME
	ARACHNIPOD SPARE PARTS
68-0054	Leg Pin
68-0036	Detent Pin
22-1002	Qik Link Head Pins
68-0035	SS Detent Pin - ³ / ₈ inch dia x 2.5 inch
68-0036	SS Detent Pin - ³ / ₈ inch dia x 3 inch
51-0058	Arachnipod Red Leg Labels - set of 3
51-0059	Arachnipod Label - Reflective Silver
51-0069	Arachnipod Bridge Trolley 250kg WLL Label
68-0042	M12 Masonry Drill Bit
	BAGS
42-1011	Arachnipod Tripod Bag
42-1020	Lazy Leg (Single Leg) Bag
90-0108	2m Bridge Bag
42-1014	3m Bridge Bag
42-1015	4m Bridge Bag
42-1012	Accessory Bag (for full accessory kit)
APOD-ADV-AB	Advantage Accessory Kit Bag



EU DECLARATION OF CONFORMITY

The Manufacturer
FERNO AUSTRALIA PTY LTD
11 JOHNSTONE ROAD
BRENDALE QLD 4500
AUSTRALIA

Declares under his sole responsibility, that the PPE described hereafter:

Equipment:	APOD – Ferno Arachnipod in versions Tripod, Quadpod and Quadpod with Bridge	
Model Numbers:	APOD-STD	Arachnipod Standard Tripod
	APOD-ADV	Arachnipod Advantage Tripod
	APOD-S2B	Standard 2m Bridge Kit
	APOD-S3B	Standard 3m Bridge Kit
	APOD-S4B	Standard 4m Bridge Kit
	APOD-QUAD	Arachnipod Quadpod

Is in conformity with the provisions of Regulation (EU) 2016/425 and with the European Harmonized standards EN795:2012 Type B and CEN/TS 16415:2013 Type B and is identical to the PPE which is subject to the EC-Type examination (Module B, Annex V of the Regulation), under certificate number CE 713429, issued by the Notified Body:

BSI Group The Netherlands B.V. (2797)
 John M. Keynesplein 9
 1066 EP Amsterdam

And is subject to the procedure set out in Annex VII (Module D) of the Regulation under the surveillance of the Notified Body:

BSI Group The Netherlands B.V. (2797)
 John M. Keynesplein 9
 1066 EP Amsterdam

Scott West
 Managing Director
 Ferno Australia

Place: Queensland, Australia
 Date: 18 August 2020

