



**SafetyLink®**  
Innovative  
Fall Protection



SCAN ME

# TempLink 5000

## Temporary Roof Anchor

### User Instruction

FIGURE 1



#### 1 Warning

- ⚠** *Improper Use, Installation or Maintenance may result in serious injury or death.*
- ⚠** *The building or structure for the anchorages should be assessed by an engineer to ensure that the structure is adequate for TempLink 5000 installation works.*
- ⚠** *SafetyLink's Height Safety Systems must only be installed as per our installation guides, to structures as specified in the installation manual for each product.*
- ⚠** *All safety procedures must be complied with in accordance with the current safety code(s) of practice(s) for working at heights in your region. Ensure safety at all times by being attached to suitable anchor points and approved safety equipment or approved scaffolding.*
- ⚠** *Installation is to be carried out by, or under the supervision of, a competent person.*
- ⚠** *A personal energy absorber or a fall-arrest device with a personal energy absorber must be used in conjunction with all SafetyLink Anchorages and Lifeline systems.*
- ⚠** *Do not carry out any modifications on this system without written permission by SafetyLink Pty Ltd.*

## 2 Specification

### 2.1 Description

The SafetyLink TempLink 5000 is a temporary single point anchor suitable for installation on metal and timber roof structures.

### 2.2 Standard

The TempLink 5000 is compliant with AS/NZS 5532:2013 and EN795:2012 - A.

### 2.3 User Rating

The TempLink 5000 is rated to 15kN and suitable for a single user. This product is not suitable for live loading or abseil. For roofs over 30°, the TempLink 5000 should be used in conjunction with other access methods to ensure no live loading.

**⚠ This product is not suitable for use as a horizontal lifeline end anchor.**

## 3 Limitations of Use

### 3.1 Fall Clearance

When planning your fall protection system, it is important to accurately assess all components of your system in order to avoid injury. Figure 2 provides guidance on how to calculate fall clearance. In Figure 2, (A) represents the deflection TempLink 5000 (300mm Max), (B) represents free fall, energy absorber deployment as well as the estimated D-ring side of the harness (Refer the manufacturer's information), (SF) represents the recommended safety factor of 1m, (FC) represents the total allowable fall clearance. For safe use (FC) shall always be greater than  $A+B + SF$ .

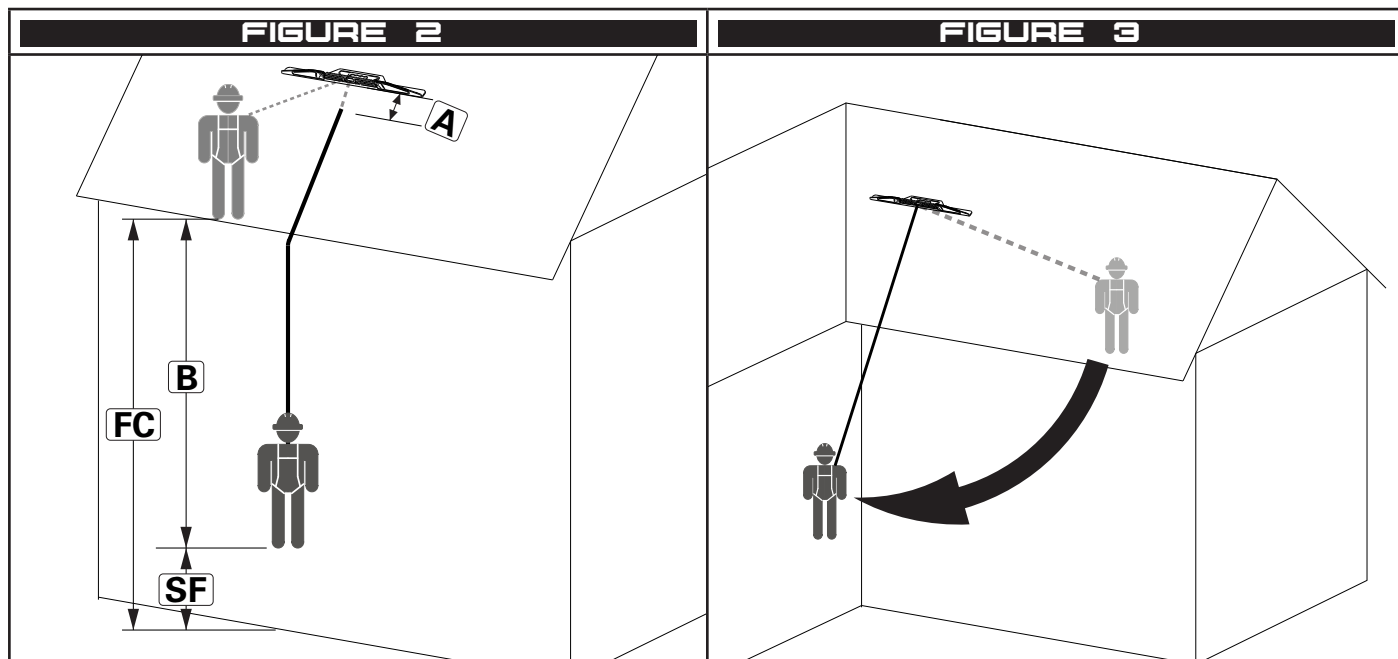

### 3.2 Swing Fall

Working off centre of an anchor point may cause a swing fall. See Figure 3. Fall protection systems shall be setup in such a way to limit swing fall.

**⚠ The force of striking an object during a swing fall may result in serious injury or death.**

### 3.3 Hazards

Use of this equipment in the presence of hazards may cause damage to the equipment and/or result in the function of the equipment being impeded. These hazards include but are not limited to; extreme temperature, sharp edges, chemical reagents, electrical conductivity, abrasion, cutting, climatic exposure and rotating or moving machinery.

### 3.4 Training

It is essential that all users are trained in the proper inspection, setup and use of this equipment. It's the responsibility of the user to ensure they are trained in the correct use of this equipment and understand the limitations of its use.

**⚠ Incorrect use of this equipment may result in serious injury or death.**

### 3.5 Rescue

It is the responsibility of the user of this equipment and their employer to have a suitable rescue plan and the ability to implement it at any time during setup and use of this equipment.

## 4 Connections

### 4.1 Making Connection

Only make compatible connections. Always ensure connectors close and lock correctly before use. Below and Figure 5 are examples of unsuitable connections;

- 1 To an anchor or D-ring which has another connector attached.
- 2 In a position that will apply load to the gate mechanism.
- 3 By passing the connection through the attachment.
- 4 Connecting a connector to another connector.
- 5 Around a structure and back to the lifeline.
- 6 To an attachment that will limit the function of the gate.
- 7 To a location that will not load the connector as designed.

### 4.2 Compatibility of Connections

Connection made to and with this equipment shall be compatible. Connector shall be compatible shape, size and equivalent rating in order to ensure a compatible connection is made. Incompatible connections may cause loading of the gate mechanism leading to unintentional disengagement. See Figure 4. Connectors shall be compliant with EN362 and auto closing and locking.

**⚠ Making incompatible or unsuitable connection may result in unintentional disengagement of the connector resulting in serious injury or death.**

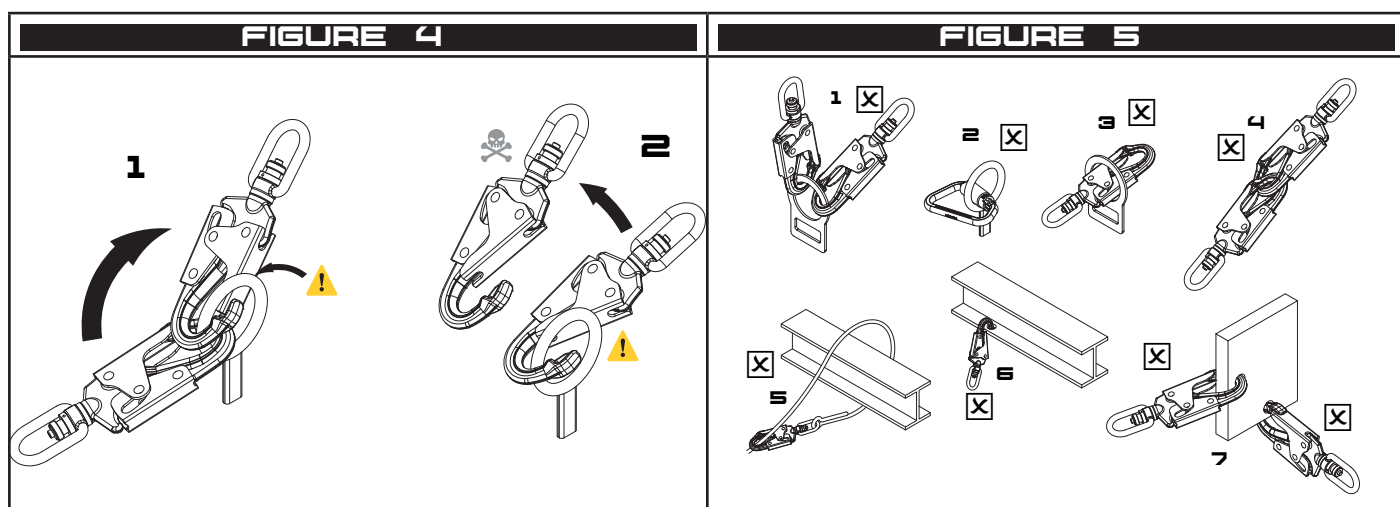

## 5 Installation and Use

### 5.1 Planning

Before starting work, plan your working at heights and rescue systems by accounting for all hazards present in the work place and allowing for the available fall clearance. Ensure all users are fit, healthy and capable of safely operating this equipment as well as implementing the rescue plan.

### 5.2 Installation

- 1 Inspect the product as per this instruction manual.
- 2 Inspect the structure to determine if it is suitable for installation (see below). Structure shall be free of damage, corrosion, rot, white ants, split timber or anything that may affect the strength of the structure. Structure shall be accordance with local building codes.
- Steel purlins shall be a minimum of 150mmx1.5mm
- Timber rafters shall be minimum 90x35mm with 70x45mm battens MGP10 or F7
- 3 Remove the existing roof sheeting screws in the area where the anchor is to be installed.
- 4 Place the anchor on the roof and install a minimum of 5x 14 gauge screws, through the mounting holes in the anchor, into the purlin or batten. Each screw shall penetrate the purlin or batten by a minimum of 35mm.

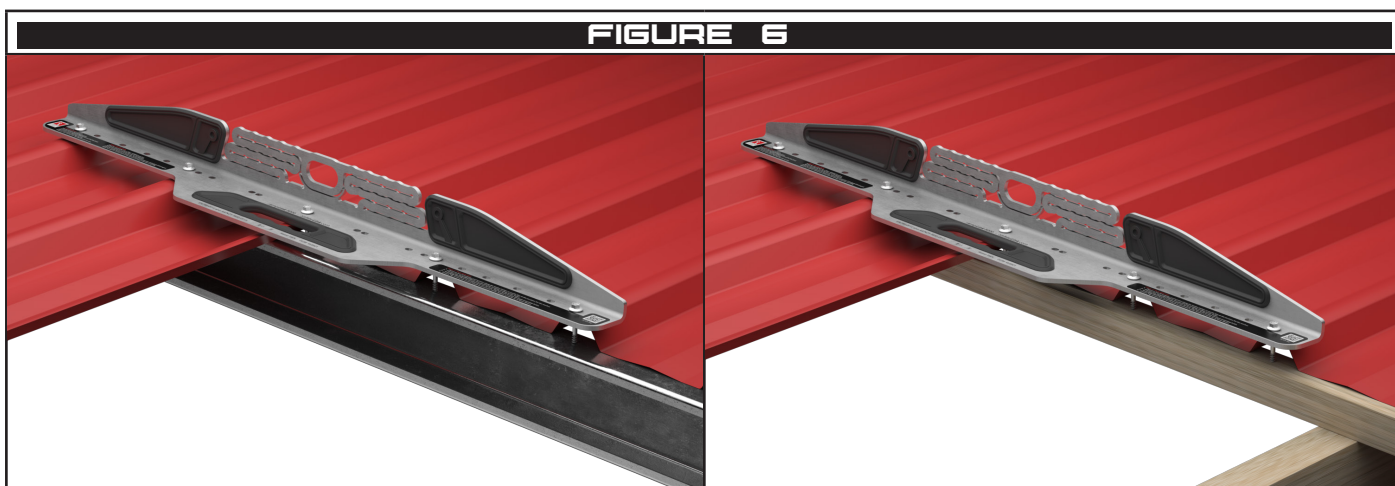

### 5.3 Use

- 1 Inspect the product and structure as per this instruction manual.
- 2 Connect the users fall arrest system to the attachment point on the product.
- 3 The product may be used with a fall direction in any direction around the product.

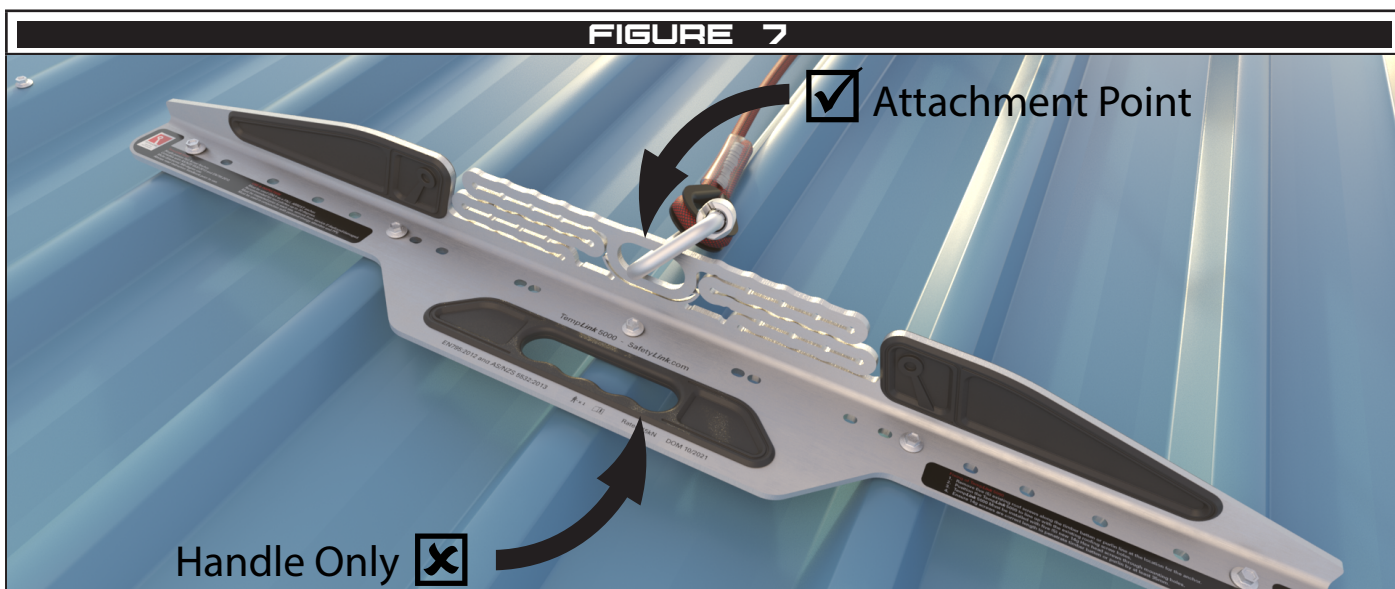

- ⚠ This product is for a single user. Do not attach multiple users to this product.**
- ⚠ The connecting system shall contain a personal energy absorber.**
- ⚠ Do not attach to any other point on the TempLink 5000 other than the specified attachment point.**
- ⚠ Use of incompatible connectors may lead to forced roll out and unintentional disconnection.**
- ⚠ Always consult the connecting system manufacturer's instruction to ensure it is suitable for use with this equipment.**
- ⚠ During use always allow for the required fall clearance, swing fall and hazards present in the work place.**

## **6 Storage, Transport and Maintenance**

### **6.1 Storage and transport**

This equipment shall be stored and transported in a cool, dry environment, away from any hazards and out of direct sunlight.

### **6.2 Maintenance**

6.2.1 The TempLink 5000 Single Point Anchor is non serviceable. The equipment may remain in service until it fails an inspection or is involved in a fall.

- ⚠ Do not attempt to modify or disassemble this product.**

### **6.3 Cleaning**

The TempLink 5000 may be cleaned by the end user periodically to increase service life. After cleaning, the product shall undergo the pre-use inspection. Clean with a rag and warm water to remove dirt and grit. A mild detergent may be used to remove grease or oils from the product.

- ⚠ Do not store this product when wet. Allow the product to dry and conduct a pre-use inspection prior to returning the item to service.**

## **7 Inspection**

### **7.1 Before and After Use**

The TempLink 5000 Single Point Anchor shall be inspected before and after each use by the user.

### **7.2 Competent Person**

A competent person shall inspect the product at least every 12 months.

### **7.3 Procedure**

7.3.1 Attachment point - inspect for damage, deformation, corrosion or signs of over loading.

7.3.2 Fall Indicators - inspect tabs are intact.

7.3.3 Screw Surface - inspect for damage, deformation, corrosion, signs of over loading twisting buckling.

7.3.4 Energy Absorber - inspect the serpentines lay flat and inline with the product. Inspect the energy absorber is free of cracks, dirt, debris, defects, damage, deformation, corrosion, signs of over loading.

7.3.5 Markings - inspect all markings are present and legible. Figure 10.

INSPECTION RECORD			
Product Code		Date of Manufacture	
Serial or Batch No.		Date of Install	
Inspector		Date of Inspection	
PROCEDURE	INSPECTION	USER	COMPETENT PERSON
7.3.1	Attachment point - inspect for damage, deformation, corrosion or signs of over loading.	<input type="checkbox"/>	<input type="checkbox"/>
	Comments:		
7.3.2	Fall Indicators - inspect tabs are intact.	<input type="checkbox"/>	<input type="checkbox"/>
	Comments:		
7.3.3	Screw Surface - inspect for damage, deformation, corrosion, signs of over loading twisting buckling.	<input type="checkbox"/>	<input type="checkbox"/>
	Comments:		
7.3.4	Energy Absorber- inspect the serpentines lay flat and inline with the product. Inspect the energy absorber is free of cracks, dirt, debris, defects, damage, deformation, corrosion, signs of over loading.	<input type="checkbox"/>	<input type="checkbox"/>
	Comments:		
7.3.5	Markings - inspect all markings are present and legible. Figure 10.	<input type="checkbox"/>	<input type="checkbox"/>
	Comments:		

**FIGURE 8**

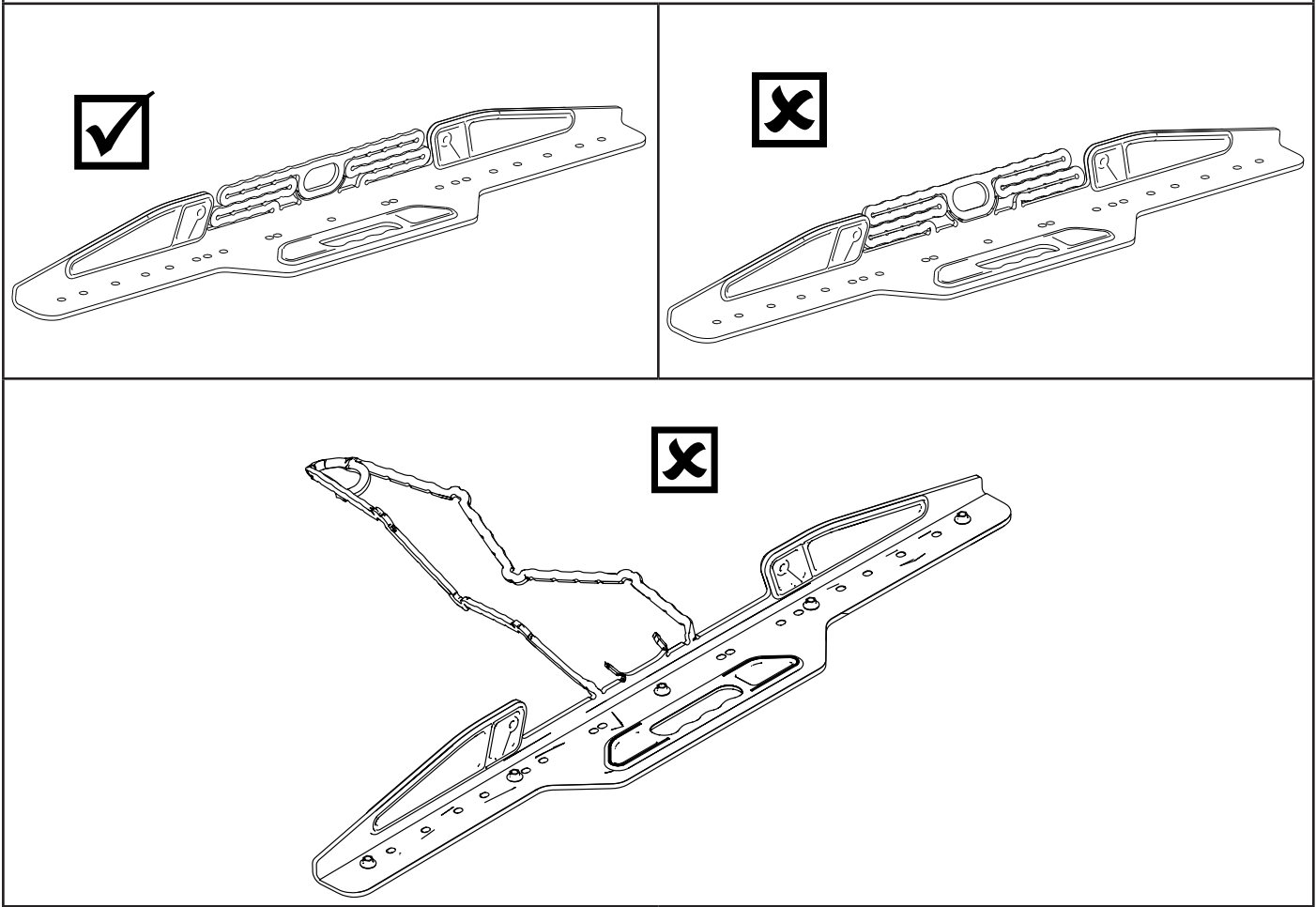

**FIGURE 9**

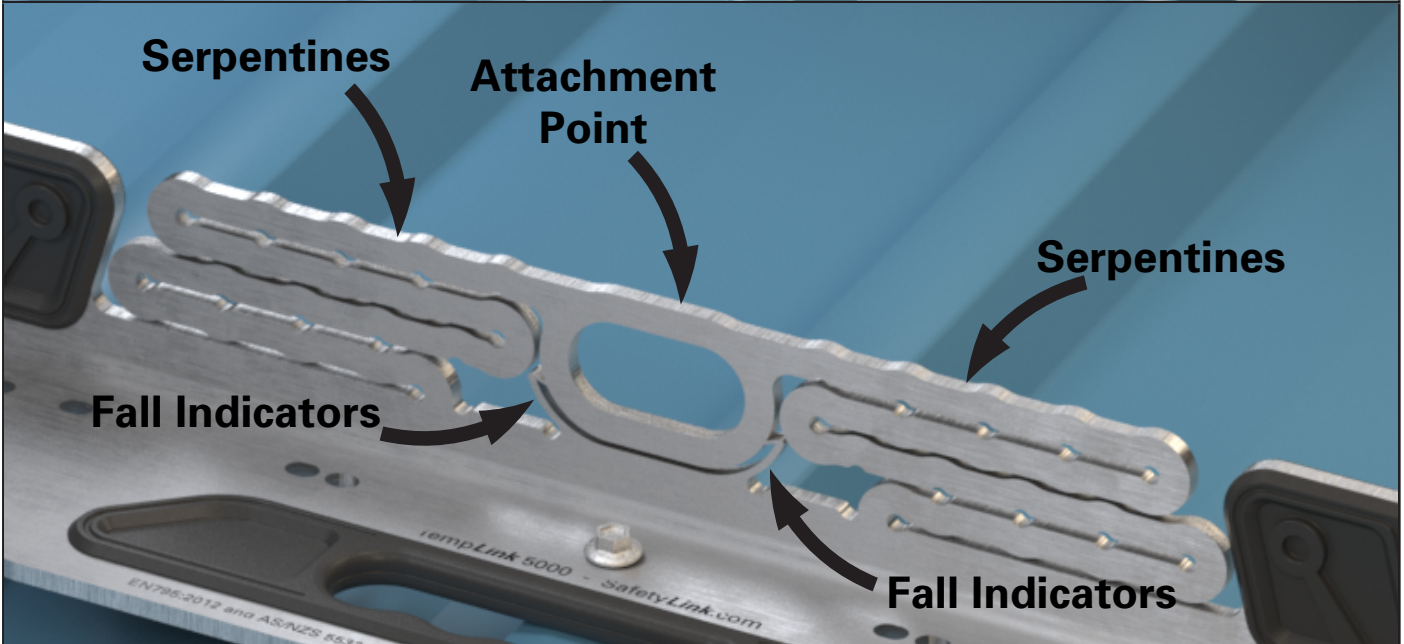
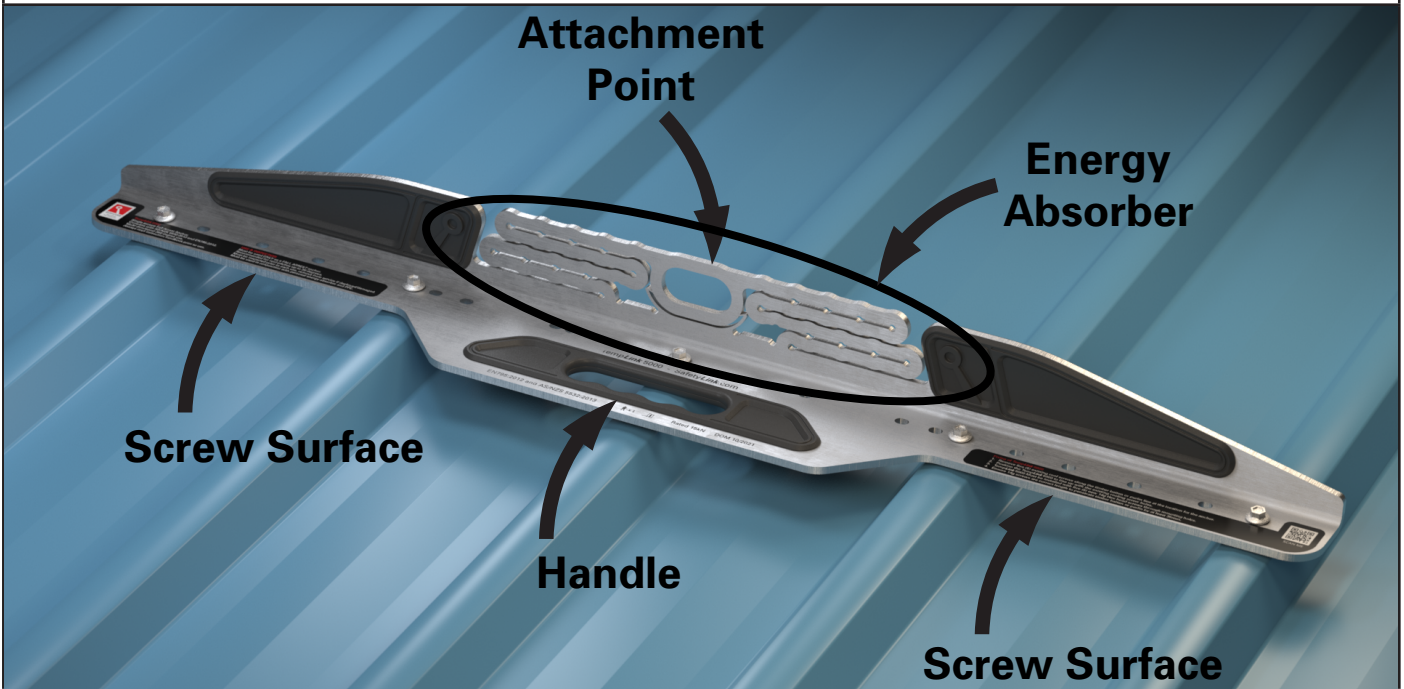

**FIGURE 10**



**TempLink 5000**  
Single person Fall Arrest Anchor.  
Complies with AS/NZS 5532:2013 and EN795:2012.  
Multi-directional 360-degree use.  
Always read instruction handbook prior to use.

**USE & INSPECTION**  
Must be used **ONLY** as a FALL ARREST anchor.  
Recommended for roof pitches up to 30 degrees.  
Must be inspected prior to each use, remove from service if deployed/damaged.  
Must be used in conjunction with personal energy absorber and PPE.

**Fixing of TempLink 5000**

1. Remove five (5) existing roof screws along the timber batten or purlin line at the location for the anchor.
2. Position the TempLink 5000 to line up with the existing roofing screw holes.
3. TempLink 5000 Must be installed with five (5) new 14g Hex head screws through mounting holes.
4. Ensure 14g screws are correct length to penetrate timber batten or purlin by at least 35mm.



SCAN ME

# WARRANTIES

## EXTRACT: SAFETYLINK PTY LTD STANDARD TERMS AND CONDITIONS

- 1.1 To the extent permitted by law all implied conditions, warranties and undertakings are expressly excluded.
- 1.2 Except as provided in this clause the Company shall not be liable for any loss or damage, whether direct or indirect (including consequential losses or damage) arising out of any breach of contract by the Company or any negligence of the Company, its employees or agents.
- 1.3 Should the Company be liable for a breach of a guarantee, condition or warranty implied by the Australian Consumer Law (not being a guarantee, condition or warranty implied by sections 51, 52 and 53 of that Law) then its liability for a breach of any such condition or warranty express or implied shall be limited, at its option, to any one or more of the following.
- A in case of Goods
- I the replacement of the Goods or the supply of equivalent Goods.
  - II the repair of the goods,
  - III the payment of the cost of replacing the Goods or acquiring equivalent Goods.
  - IV the payment of the cost of having the Goods repaired. Provided that any such Goods are returned to the Company by the Purchaser at the Purchaser's expense.
- B in the case of services
- I the supply of the services again,
  - II the payment of the cost of having the services supplied again.
- 1.4 The Company is not liable for the costs of recovery of the Goods from the field, loss of use of the Goods, loss of time, inconvenience, incidental or consequential loss or damage, nor for any other loss or damage other than as stated above, whether ordinary or exemplary, caused either directly or indirectly by use of the Goods.
- 1.5 The Company warrants that at the time of shipment, Products manufactured by it will be free from defects in material and workmanship. In the absence of a modified written warranty, the Company agrees to making good any such defects by repairing the same or at the Company's option by replacement, for a period of (1) one year from the date of shipment. This limited warranty applies provided that:
- a defects have arising solely from faulty materials or workmanship;
  - b the Products have not received maltreatment, inattention or interference;
  - c the Products have been installed in accordance with the Company's Installation Handbooks using only products supplied by the Company;
  - d accessories used with the Products are manufactured by or approved by the Company
  - e the Products are maintained in accordance with Australian Standard 1891.4 (section 9).
  - f you notify any claim under this warranty to SafetyLink in writing to the address below no later than 14 days after the event or occurrence concerning the produce giving rise to the claim and you pay all costs related to your claim.

This warranty does not apply to any defects or other malfunctions caused to the Goods by accident, neglect, vandalism, misuse, alteration, modification or unusual physical, environment or electrical stress.

Please note that the benefits to the purchaser (as a consumer) given by this warranty are in addition to your other rights and remedies under the Australian Consumer Law. Our goods come with guarantees that cannot be excluded under the Australian Consumer Law. You are entitled to a replacement or refund for a major failure and compensation for any other reasonably foreseeable loss or damage. You are also entitled to have the goods repaired or replaced if the goods fail to be of acceptable quality and the failure does not amount to a major failure.

- 1.6 If any goods are not manufactured by the Company, the guarantee of the manufacturer thereof shall be accepted by the Purchaser as the only express warranty given in respect of the goods.
- 1.7 Except as provided in this clause 11, all express and implied warranties, guarantees and conditions under statute or general law as the merchantability, description, quality, suitability or fitness of the Products for any purpose or as to design, assembly, installation, materials or workmanship or otherwise are hereby expressly excluded (to the extent to which they may be excluded by law).

**PLEASE SEE SAFETYLINK PTY LTD FULL STANDARD TERMS OF CONDITIONS OF SALE FOR FURTHER REFERENCE.**



FS 707792

SafetyLink Pty Ltd | ABN 83 081 777 371 | [www.safetylink.com](http://www.safetylink.com)

Head Office: 54 Bonville Ave, Thornton, 2322, NSW, Australia

1300 789 545 | +61 2 4964 1068

Asia-Pacific/The Americas | [info@safetylink.com](mailto:info@safetylink.com)

Europe/Africa/Middle East | [europe.sales@safetylink.com](mailto:europe.sales@safetylink.com)

Northern Europe | [uk.sales@safetylink.com](mailto:uk.sales@safetylink.com)