

# Anchors for building maintenance

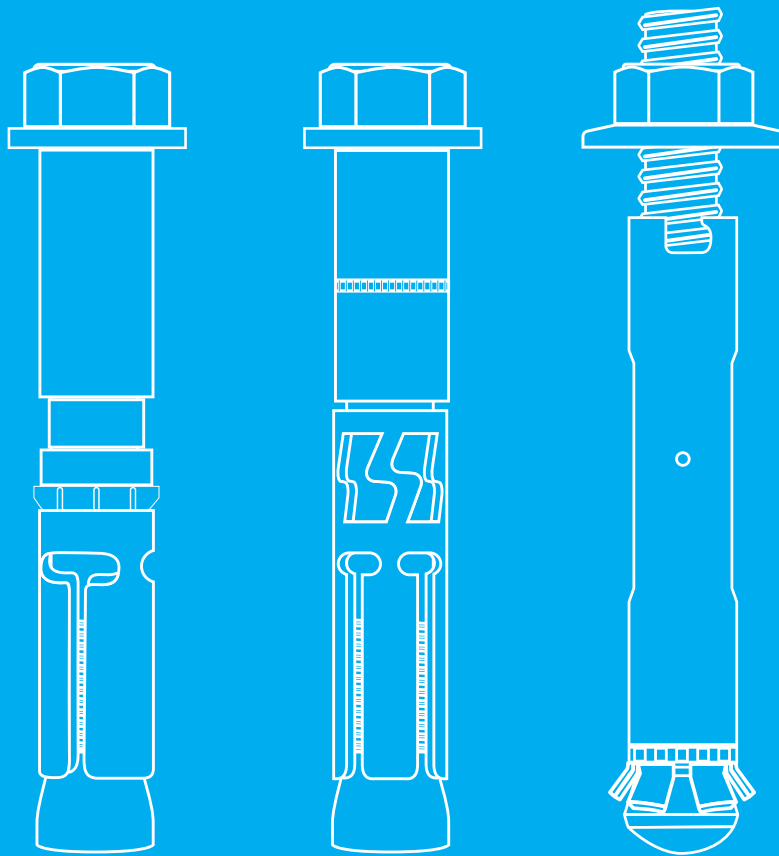

# Contents

Introduction .....	1
Purpose .....	1
Scope.....	1
Issue .....	1
Manufacturer’s information .....	2
Anchor definition .....	2
Screw bolts .....	2
Torque controlled thick sleeve anchor (not including thin sleeve/deformation anchors) .....	2
Chemical anchors .....	3
Sleeve anchors (torque-controlled expansion anchor with thin expansion sleeve).....	3
Coil bolts .....	3
Drop-in anchors (deformation-controlled anchors) .....	3
Anchor location and function.....	3
Attachment points with multiple anchors.....	4
Quality control of anchor installation .....	4
Periodical inspection and testing of the anchorage system .....	4
Combining anchorage systems from different manufacturers .....	4
Site documentation and marking .....	4
QBCC licensing .....	5
Safe use of anchors .....	5
Post-installed anchors .....	5
Undercut anchors .....	5
Appendix 1: Post-installed anchor types .....	6
Appendix 2: Extracts from relevant Australian Standards <sup>5</sup> .....	7
Appendix 3: Loading .....	8

 [worksafe.qld.gov.au](https://worksafe.qld.gov.au)

 1300 362 128

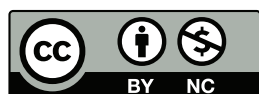

State of Queensland 2019.

Unless otherwise noted, this document is available under a Creative Commons Attribution 4.0 International licence. You are free to copy, communicate and adapt the work, so long as you attribute The State of Queensland. For more information see: <https://creativecommons.org/licenses/by-nc/4.0/>.

The material presented in this publication is distributed by the Queensland Government for information only and is subject to change without notice.

The Queensland Government disclaims all responsibility and liability (including liability in negligence) for all expenses, losses, damages and costs incurred as a result of the information being inaccurate or incomplete in any way and for any reason. PN12492

# Introduction

Falls are a major cause of death and serious injury in Australian workplaces. Fall hazards are found in many workplaces where work is carried out at height, including work involving industrial rope access and building maintenance.

The design, manufacture or modification of any building or structure can significantly affect the risk of falls. At the early design stage, consideration should be given to possible ways that fall hazards could be eliminated or minimised.

Designers or constructors of buildings or structures must ensure, so far as is reasonably practicable, that workers involved with the construction, use or subsequent maintenance are not exposed to the risks associated with work at height. At the design and planning stage, it is important to consider providing one or more systems designed to prevent falls as part of the building or structure. This includes considering the methods by which maintenance, repairs or cleaning will be carried out on a building or structure, for example:

- designing window cleaning bays or gangways integrated into the structural frame
- designing permanent anchorage and hoisting points into structures where maintenance needs to be carried out at height.

A person conducting a business or undertaking must eliminate the risk of falls in the workplace, or if that is not reasonably practicable, minimise those risks so far as is reasonably practicable.

Requirements include:

- ensuring any work involving the risk of a fall is carried out on the ground or on a solid construction
- providing safe means to access and exit a workplace
- minimising the risk of falls by providing a fall prevention device, work positioning system or a fall arrest system.

The most effective way to protect workers from the risk of falling is to eliminate the need to work at height.

This guide should be read in conjunction with the *Work Health and Safety Act 2011*, *Work Health and Safety Regulation 2011*, *Electrical Safety Act 2002* and relevant codes of practice.

# Purpose

This guide provides information about the safe use of post-installed anchors<sup>1</sup> for fall arrest and industrial rope access attachment points used for building maintenance, including both single anchor point and multi-fixing anchor points.

<sup>1</sup> For the purposes of this guide the term ‘anchor’ describes the post-installed anchor itself and ‘attachment point’ - the complete anchorage assembly including the post-installed anchor(s), mounting plate and/or eyelet.

# Scope

The guide covers various types of post-installed anchors (i.e. masonry anchors) including:

- torque-controlled
- chemical
- screw bolt
- undercut
- deformation-controlled anchors.

The guide clarifies the type of anchors that may be used in an overhead application.

Although not included within the scope of this guide, cast-in inserts (threaded inserts or ferrules), anchor channels or ‘through-bolts’ may also be used for the purpose of fall protection.

In the case of any anchorage system, documentation verifying the design, installation and maintenance of the systems should be available on site. Appendix 1 provides examples of the anchors referred to in the guide.

This guide does not provide detailed information on post-installed anchors and is intended as general guidance. Detailed information on whether a post-installed anchor is suitable for a fall arrest or rope access application should be sought from the anchor manufacturer.

# Issue

The Australian/New Zealand Standards that apply to fall arrest and rope access systems (AS/NZS 1891.4-2009 and AS/NZS 4488.2-1997 respectively) specify that “drilled-in” (post-installed) anchorages such as friction and glued-in anchors are not to be loaded in direct tension (see Appendix 2 for relevant extracts of these standards). According to both standards, the applied shear load is to be at least twice the tension load (for a collared eye-bolt this translates to a pull at a maximum angle of approximately 20° to the surface in which the bolt is installed – see Diagram 1).

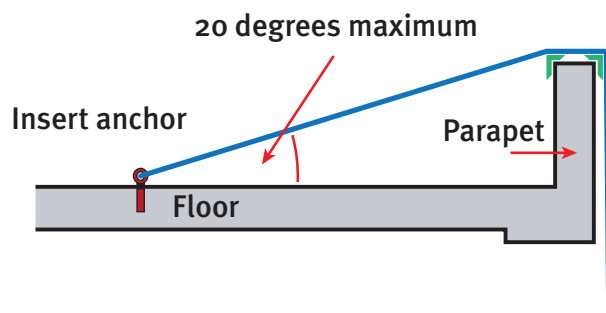

Diagram 1: Maximum allowable angle as specified in AS/NZS 4488.2-1997 for all types of post-installed anchors.

In some situations, anchor manufacturers have indicated that certain anchors within their range—such as an undercut anchor—do not fall within the category of a ‘friction or glued in anchor’ and therefore may be used in situations where the anchor is loaded in direct tension. In these instances, very strict installation conditions apply.

When a post-installed anchor is incorrectly installed and used in pure tension <sup>2</sup>, catastrophic failure of the anchor and/or substrate material will likely have fatal consequences, particularly if there are no secondary or back-up measures in place. While many post-installed anchors are of a high quality, anchors can potentially fail due to factors including degradation of materials (e.g. steel, concrete) over time or simply due to the anchors not being installed correctly. Annual proof testing specified in the standards (i.e. axial pull-out force of 50 per cent of the ultimate design strength in direction of loading) provides some confidence that the anchors will continue to operate correctly. However, testing alone does not guarantee that the anchors will continue to perform as designed where ongoing maintenance of the anchorage system is lacking (e.g. the anchors have been allowed to rust and/or the concrete substrate is visibly damaged).

The load carrying capacity of an anchor is affected by the strength of base material (i.e. concrete), its thickness, and the proximity of the anchor to the edge/s of concrete and other nearby anchors. The spacing and edge distances must be taken into account to determine the capacity of anchorage. The anchor can corrode in outside exposed environments. Therefore an anchor of suitable corrosive resistance for the life of the anchorage system must be selected.

## Manufacturer's information

Larger post-installed anchor manufacturers provide comprehensive instructions and specifications for their anchorage systems. The information includes drilled hole size, concrete specification, spacing distances, edge distances, tightening torques and other instructions to ensure the anchors perform as intended by the manufacturer. While the anchor manufacturers provide information on tensile (i.e. pull out) and shear capacities, information about the capacity for other examples of anchor loading is limited. The type and direction of loading applied is particularly important to safety applications such as fall arrest or rope access applications, where failure of the attachment point can result in a fatality. In addition, manufacturer's information on the allowable tolerance of the drilled hole size may be limited. It is therefore critical that the competent person designing the system selects products with both the immediate and long term use and testing considerations in mind.

While anchor manufacturers often provide a considerable amount of technical information on the performance of their anchors, the technical specifications may not state that the anchors are suitable as fall arrest or rope access anchors. The competent person involved in the selection of the anchors is sometimes required to determine this and may need to seek additional information from the anchor manufacturer.

---

<sup>2</sup> Depending on the shape of the attachment point, even with a purely horizontal load, the resultant force on the anchors themselves may have a small amount of tension force on the anchors themselves. This can generally be ignored. See Appendix 3 for more information.

## Anchor definition

AS/NZS 1891.4-2009 and AS/NZS 4488.2-1997 use the terms 'drilled-in, friction or glued-in' to describe insert anchors currently available. However, the term 'drilled-in' may cause some confusion – while it is intended to include screw bolts, this may not be the case. The term 'friction anchor' appears to describe torque-controlled post-installed mechanical anchors assembled with an expansion sleeve and deformation-controlled anchors (e.g. drop-in anchors). 'Glued in' reasonably describes chemical anchors where the anchor relies on the bond strength of the chemical (e.g. two part epoxy mix) for the anchor to function.

Undercut anchors are not currently described by either AS/NZS 1891.4-2009 or AS/NZS 4488.2-1997.

## Screw bolts

Screw bolt anchors, where the anchor cuts a thread in the concrete hole, rely on tight tolerances on the drilled hole and overtightening may be a problem. A high quality torque-controlled post-installed anchor can tolerate some minor variations in the drilled hole diameter because the wedge shield expands as the anchor is tightened but it is necessary to always follow the hole diameters recommended by the manufacturer of the anchor. However, in the case of a screw bolt, the diameter of the bolt and its thread is fixed. The pull out resistance is based on the effectiveness of the grooves that are cut by the bolt's thread during installation. If the hole is too large, the grooves cut by the thread will not be deep enough and the anchor will not achieve adequate pull out resistance.

Due to the difficulty associated with achieving tight tolerances when drilling holes in concrete and the absence of information from manufacturers verifying the use of screw bolts for safety applications, screw bolts are unsuitable for any fall arrest or industrial rope access attachment points.

## Torque controlled thick sleeve anchor (not including thin sleeve/deformation anchors)

Most anchor manufacturers supply high quality torque-controlled thick sleeve expansion anchors that may safely withstand cyclic loading for extended periods of time. Where the manufacturer states that a torque-controlled anchor is suitable for safety applications with cyclic loading, these anchors may be used in attachment points for either fall arrest or industrial rope access. However, with both fall arrest and rope access applications, the direction or angle of loading shall be such that the applied shear load should still be at least twice the tension load in accordance with AS/NZS 1891.4-2009 and AS/NZS 4488.2-1997 (i.e. angle of loading does not exceed 20 degrees from the horizontal).

## Chemical anchors

Chemical anchors rely on an effective bond between the anchor rod (e.g. threaded rod) and concrete being maintained for the life of the installation. Fall arrest and rope access attachment points on buildings are normally provided as long term fixtures and are exposed to the elements. Degradation of the connection between the anchor rod and the concrete may occur over time.

For these reasons the restrictions for ‘glued-in’ anchors specified in AS/NZS 1891.4-2009 and AS/NZS 4488.2-1997 should be applied to all chemical anchors used for fall arrest and rope access. This includes annual pull out testing of every attachment point and ensuring the angle of the fall arrest or rope access line does not exceed 20° to the surface in which the bolt is installed. A threaded rod or deformed reinforcing bar are the only steel parts recommended to be installed with chemical adhesive systems according to the manufacturer’s installation instructions. Therefore, the length that bonds with the adhesive shall either have threads or be made of a deformed bar.

## Sleeve anchors (torque-controlled expansion anchor with thin expansion sleeve)

Sleeve anchors generally have thin expansion sleeves and rely on expansion of the sleeve to create a friction connection between the anchor assembly and the concrete hole. These anchors function similar to a torque-controlled anchor but sleeve anchors are cheaper and generally not intended for safety applications. While these anchors can effectively resist an initial high loading, their ongoing performance for repeated loading (i.e. as applied by rope access) is poor.

Sleeve anchors should not be used for fall arrest or industrial rope anchorage points.

## Coil bolts

Coil bolts have been used for a number of years in the Queensland construction industry and are commonly used as anchors for scaffolding ties. The anchors are used to ensure stability of the scaffolding and resist wind loading applied to the scaffolding. However, it should be noted that when used as scaffolding tie anchors, failure of a single anchor will not cause the scaffolding to collapse (i.e. the design has redundancy). Coil bolt manufacturers are unlikely to specify that these anchors can be used for fall arrest or rope access applications. Coil bolts are deformation-controlled anchors without the high load performance of torque-controlled thick sleeve expansion anchors. Coil bolts should not be used for fall arrest or rope anchorage points unless the anchor manufacturer states that the anchors are suitable for this purpose.

## Drop-in anchors (deformation-controlled anchors)

Drop-in anchors should not be used for fall-arrest or rope anchorage points on new installations.

Existing installed systems using drop-in anchors (where the manufacturer has tested and approved the whole system and subject to the approval of the engineer) may be used, provided they satisfy the periodic inspection regime as detailed later in this guide.

After drilling the hole, the drop-in anchor is inserted into the hole. A stepped steel setting tool/punch is then used with a hammer to push a ‘plug/wedge’ of metal down towards the end of the anchor. This action causes the slotted bottom section of the anchor to expand outwards and hence wedge the anchor in the drilled hole. Manufacturers typically only recommend these anchors for non-critical or redundant applications where multiple anchors are used to support the loads such as suspended pipes, ceilings and ductwork.

## Anchor location and function

Irrespective of whether the system to be installed is a fall arrest or rope access system, the location of the attachment points is extremely important. The layout of the system must be designed by a competent person who is familiar with the safe use of the system. Attachment points are to be positioned so that they can be safely approached by the user without the risk of the user falling while they are accessing the attachment point.

In fall arrest applications only one attachment point for the fall arrest line is usually provided. If this attachment point fails catastrophically, the user will fall to the ground or hit obstructions in the worker’s fall path. In the case of industrial rope access systems, two attachment points are used, one for the working rope and one for the back-up rope. In addition, diverter attachment points (also known as diversion or deviation anchor points) are sometimes provided in addition to the primary rope attachment points.

Diverter attachment points are sometimes provided so that a worker can gain access under an overhang. If the diverter attachment point fails any injuries are likely to be minor assuming that the main attachment points don’t fail. If the diverter point fails, the worker will swing outwards and be suspended from the main attachment points, or another diverter point<sup>3</sup> if the overhang is substantial. The main attachment point should have anchors that are not acting in pure tension.

---

<sup>3</sup> As a general guide the distance between subsequent diverter attachment points should not exceed 600 millimetres so that the user is able to move from point to point.

## Attachment points with multiple anchors

Some fall arrest and rope access attachment point suppliers have been installing attachment plates using two or more post-installed anchors. This is an attempt to provide attachment points with some design redundancy so that both anchors need to pull out for failure to occur. Undercut anchors are a reasonable alternative for diverter attachment points, if the anchor installers are competent and there has been an engineering assessment of the concrete substrate.

In some situations multiple anchor attachment points, where the anchors are loaded in direct tension (pull out loads), have been provided as the primary rope access or fall arrest attachment point. This is not a preferred position. However, in this situation the certifying engineer should carry out an on-site assessment of the concrete and identify if the attachment point has been installed by a competent person. The certifying engineer will need to carry out an adequate amount of examination and/or testing so as to be able to come to an informed decision about the ability of the anchorage system to safely withstand its design loads.

## Quality control of anchor installation

Most engineering certification of fall arrest and rope access appears to be carried out without the engineer witnessing the installation of the anchors nor carrying out a site inspection. The certification appears to consist of the engineer referring to the manufacturer's data for the anchors and then certifying the anchors will adequately withstand potential loading if the anchors are installed in accordance with the manufacturer's instructions.

There is a large variation of skill levels of persons installing post-installed anchors. In response to this issue, the Australian Engineered Fasteners and Anchors Council (AEFAC) has developed a course for anchor installers. After successful completion of the course the attendee becomes an AEFAC certified anchor installer and a licence card is issued. To maintain competency anchor installers are required to attend a refresher course within three years after the initial course and then at five yearly intervals.

Successful completion of the AEFAC anchor installer course is one way of providing evidence that the installer has the suitable skills, knowledge and competency to ensure anchors have been installed in accordance with the manufacturer's instructions. An alternative method of providing evidence is for anchor installers to complete an anchor manufacturer's theoretical and practical training course for the installation of anchors in accordance with the manufacturer's installation instructions.

## Periodical inspection and testing of the anchorage system

AS/NZS 1891.4-2009 and AS/NZS 4488.2-1997 specify load testing of insert type anchor installations at intervals not exceeding 12 months. This load testing is to be carried out by a competent person using equipment that complies with the load testing requirements of the anchor manufacturer. In addition to the load test itself, the competent person should make an assessment of the condition of the anchorage system including the anchor itself and the surrounding concrete. If visual signs of degradation are observed (e.g. corrosion, concrete damage and anchor movement) the anchorage system should be marked as being unsafe and procedures implemented on site to ensure the defective anchorages are not used.

## Combining anchorage systems from different manufacturers

If an anchor or anchorage system has been created using a series of components from different manufacturers, additional assessment should be carried out. Where such a system is used it should be verified and certified by an engineer who considers both the system's load capacity and suitability. Proprietary anchorage products provided by reputable manufacturers will be supported with relevant engineering calculations and/or testing information that demonstrates the product's ability to withstand fall arrest loads. Where a combination of products is used, the design parameters of a product could be affected and the certifying engineer should address this issue.

## Site documentation and marking

On site documentation should be provided demonstrating:

- the location of each attachment point
- the intended function of each attachment point (i.e. fall arrest or industrial rope access, primary attachment point or diverter attachment point in the case of rope access)
- the name, signature, certification date and company name of the certifying engineer (i.e. completion of Department of Housing and Public Works - Form 15). In the case of anchors being used in direct tension the engineering assessment should include an on-site assessment of the concrete substrate
- the name and qualifications of the installer of the attachment points and the name of the installation company
- the name, date and signature of the competent person carrying out the 12 monthly inspections of attachment points (including evidence of test loading such as photographs)
- safe use instructions for the system including photographs and or diagrams of the attachment points.

Both AS/NZS 1891.4-2009 or AS/NZS 4488.2-1997 specify that at intervals not exceeding 12 months, post-installed anchors used shall be tested to an axial (pull out) load equivalent to 50 per cent of their design load. This corresponds to a test pull-out load of 6 kilonewtons (kN) for industrial rope access anchors and 7.5 kN for fall arrest anchors.

Fall arrest and industrial rope access attachment points are not to be used if documentation verifying the anchors have been designed, installed and periodically inspected is not available.

## QBCC licensing

In some situations a Queensland Building and Construction Commission (QBCC) licence is required to install rope access and fall arrest anchor points. This depends on the scale and value of the works being considered for the installation of anchor points for a rope access or fall arrest system. People installing these anchors should consult with QBCC. Call QBCC on 13 93 33.

## Safe use of anchors

The following position for industrial rope access and fall arrest attachment points is reasonable based on the contemporary knowledge including information found in AS/NZS 1891.4 and AS/NZS 4488:

### Post-installed anchors

- Every anchor shall be proof loaded (axial pull-out test) after installation in accordance with the manufacturer's installation instructions prior to its initial use. The proof load shall be applied as an axial pull-out force. Proof loading to 50 per cent of design load should also be carried out as part of subsequent periodic inspections. For fall arrest anchorages this proof load corresponds to a pull-out force of 7.5 kN and for rope access anchorages a pull-out force of 6 kN. The load testing is not to damage the integrity of the attachment point in any way. For further information, the certifying engineer and/or the anchor manufacturer should be contacted.
- An anchor with proper corrosion protection suitable for the location and application shall be used. Suitably galvanised coated or stainless steel anchor should be considered for outside applications exposed to weather conditions for longer time periods.
- The anchor point and strength of the anchor shall be determined by considering the thickness and strength of concrete, edge and spacing distance effects according to manufacturer's recommendations.
- Attachment points are not to be used if documentation verifying the anchors have been designed, installed and periodically inspected is not available.
- Single undercut anchors are suitable for use as either fall arrest or rope access attachment points where the shear load is to be at least twice the tension load.
- Multiple undercut anchors on a single anchor plate are suitable for use for a diverter attachment point on a rope access system, provided the minimum spacing distances between individual anchors comply with the manufacturer's specifications. The spacing of subsequent diverter points should not exceed 600 millimetres. Diverter attachment points should be marked as being a diverter attachment point for use only with industrial rope access equipment. In some exceptional situations this same combination could be used for the primary attachment point with tensile (pull out) loading if there is verification that the certifying engineer has carried out an onsite inspection of the concrete and the installer is competent<sup>4</sup> (i.e. completion of the AEFAC certificate).
- Torque controlled thick sleeve anchors (not including thin sleeve/deformation anchors) are suitable for use as either fall arrest or rope access anchors where the shear load is to be at least twice the tension load. There are no other loading applications.
- Chemical anchors are suitable for use as either fall arrest or rope access anchors where the shear load is to be at least twice the tension load. There are no other loading applications. The suitability of the adhesive should be checked before use (e.g. if the adhesive is suitable for core-drilled holes and temperature conditions). Most adhesives work in hammer-drilled holes in dry concrete but there are only limited adhesives that work in core-drilled holes, wet/flooded holes and high temperatures. Check the suitability before use.
- Sleeve anchors (torque-controlled thin sleeve anchor), screw bolts and coil bolts should not be used. In the absence of manufacturer's instructions that state that screw bolts are a suitable anchorage for fall arrest or rope access systems, these anchor types should not be used in these applications irrespective of whether the anchors are being used in direct tension or shear.
- Drop-in anchors should not be used for fall arrest or rope access systems.

---

<sup>4</sup> All fall arrest and rope access anchors should be installed by a competent person. However, at this stage, as there is a limited number of AEFAC accredited installers, it may be difficult to meet this benchmark for all fall arrest and industrial rope attachment points.

# Appendix 1: Post-installed anchor types

Chemical anchor

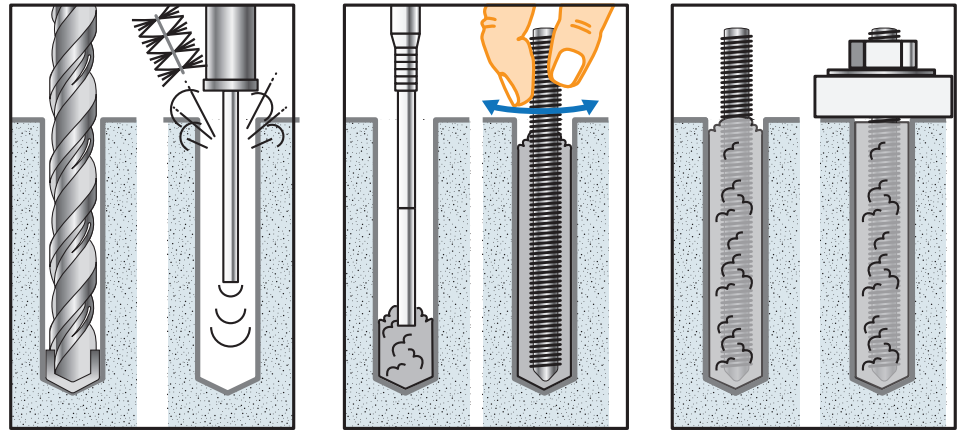

Torque-controlled thick sleeve expansion anchor  
(two examples)

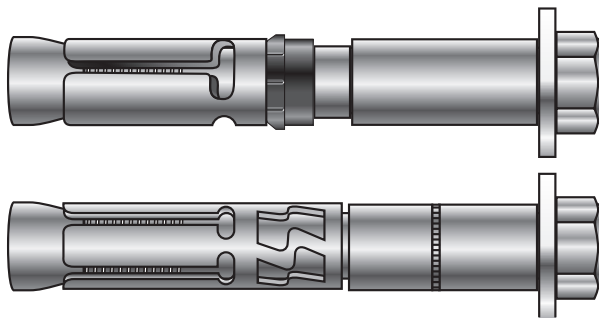

Coil bolt

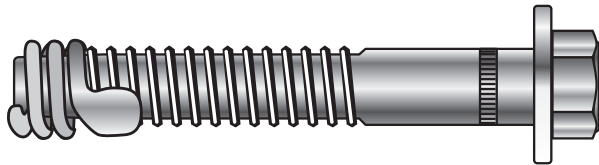

Drop-in anchor  
(also known as deformation controlled anchor)



Sleeve anchor

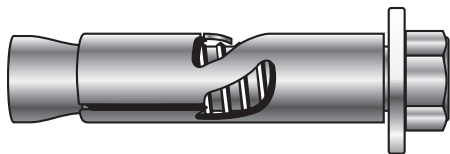

Screw bolt

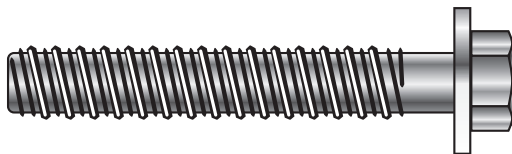

Undercut anchor

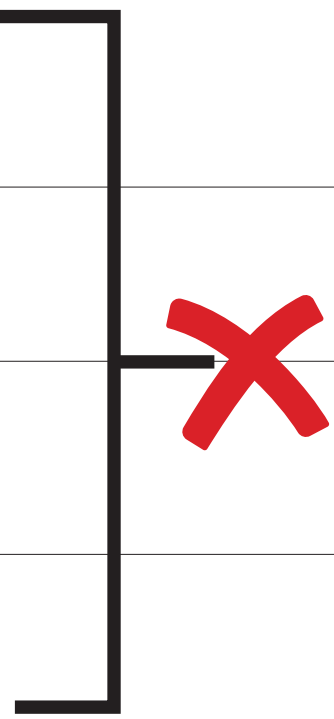
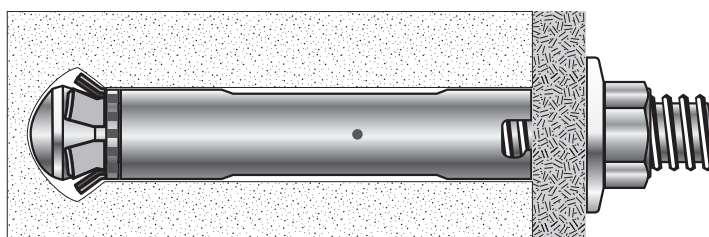



## Appendix 2: Extracts from relevant Australian Standards<sup>5</sup>

1. AS/NZS 1891.4 – 2009 Industrial fall arrest systems and devices: Selection use and maintenance. Section 3.1.2(g):

“Single point anchorages suitable for direct connection of personal fall-arrest equipment

In addition to any specific requirements of the manufacturer of the anchorage system or other related equipment, the following requirements and recommendations for the selection and location of anchorages apply:

(g) Where used, drilled-in anchorages such as friction and glued-in anchorages shall be placed so that the shear load is at least twice the tension load. For collared eye-bolts this translates to a pull at an angle not exceeding 20° to the surface in which the bolt is installed.

Every friction and glued-in anchorage shall be proof loaded to 50% of the design ultimate strength specified in Table 3.1 in accordance with manufacturer’s instructions after installation and prior to its initial use. The proof load shall be applied as an axial pull-out force. Proof loading to 50% of design load shall also be carried out as part of subsequent periodic inspections.”

2. AS/NZS 4488.2 – 1997 Industrial rope access systems: Selection use and maintenance. Section 5.3(a)(i) & (viii):

“Anchorages suitable for the direct connection of lines

Requirements and recommendations for the selection and location of anchorages are as follows:

(i) The anchorage and the structure to which it is attached shall be capable of sustaining an ultimate load of 12 kN when loaded in the direction of the rope pull during industrial rope suspension work. The building or structure and anchorages shall be assessed by an engineer, unless it is clear to a competent person that the anchorage system is structurally adequate. An example of where an engineer may not be required is where an anchorage sling of the correct capacity is secured around a solid permanent structure such as a plant room. However, if any doubt exists as to the structural adequacy of the anchorage, an engineer shall make the assessment. Dynamic loads under fall-arrest conditions can be considerably higher than the static loads. If called upon to make the assessment the engineer shall certify in writing that all combinations of loads in a worst case situation can be safely contained by the proposed structure and anchorage points.

(viii) Where used, drilled-in, friction and glued-in anchorages shall be placed so that the shear load is at least twice the tension load. For collared eye-bolts this translates to a pull at an angle not exceeding 20 degrees to the surface in which the bolt is installed.”

---

<sup>5</sup> AS/NZS 1891.4-2009 & AS/NZS 4488.1:1997[R2017]  
© Standards Australia Limited. <1% Copied by Qld Office of Industrial Relations with the permission of Standards Australia and Standards New Zealand under Licence 1811-c118.

## Appendix 3: Loading

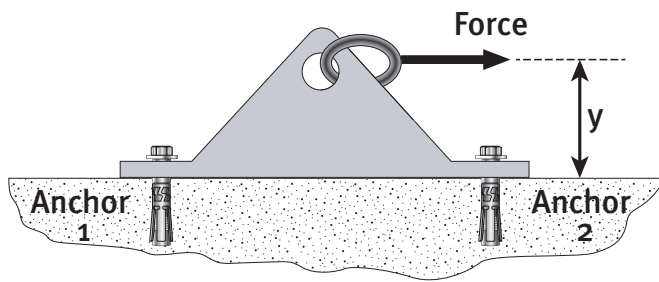

The force applied to the attachment point is a horizontal load. However, as the load is applied at a distance “y” above the attachment surface, a small amount of vertical loading will be applied to both bolts – this force can tend to “prise” the bolts out of their holes. As long as “y” remains small (i.e. less than 50 millimetres) the force applied to prise the anchors out of their holes can be considered negligible.