

MILLER[®]
by SPERIAN

Miller
SKY GRIP[™]
Horizontal Lifeline Systems

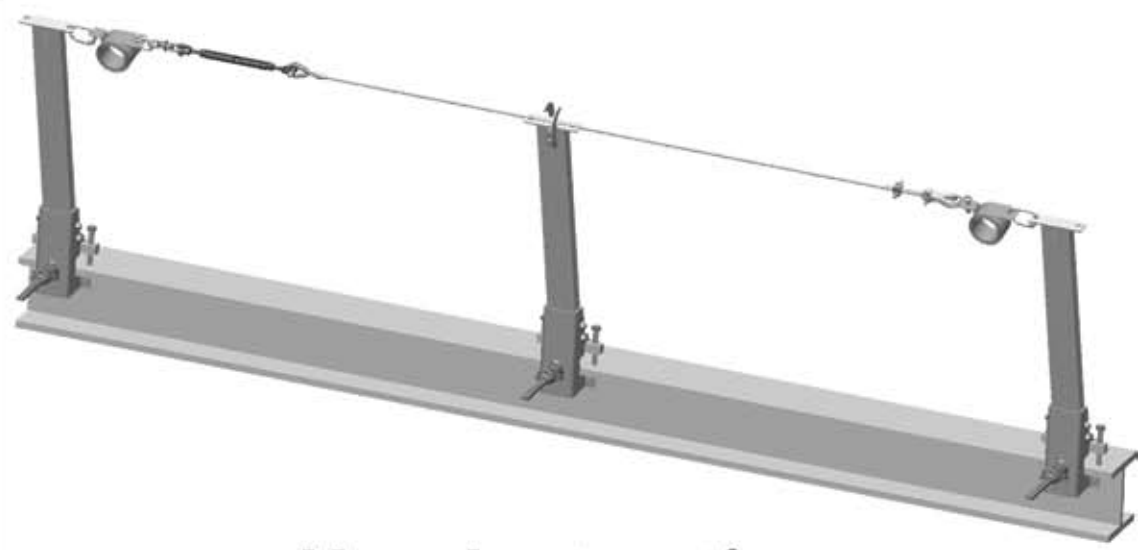

User Instruction Manual

Manuel D'utilisation

Manual de Instrucciones
para El Usuario

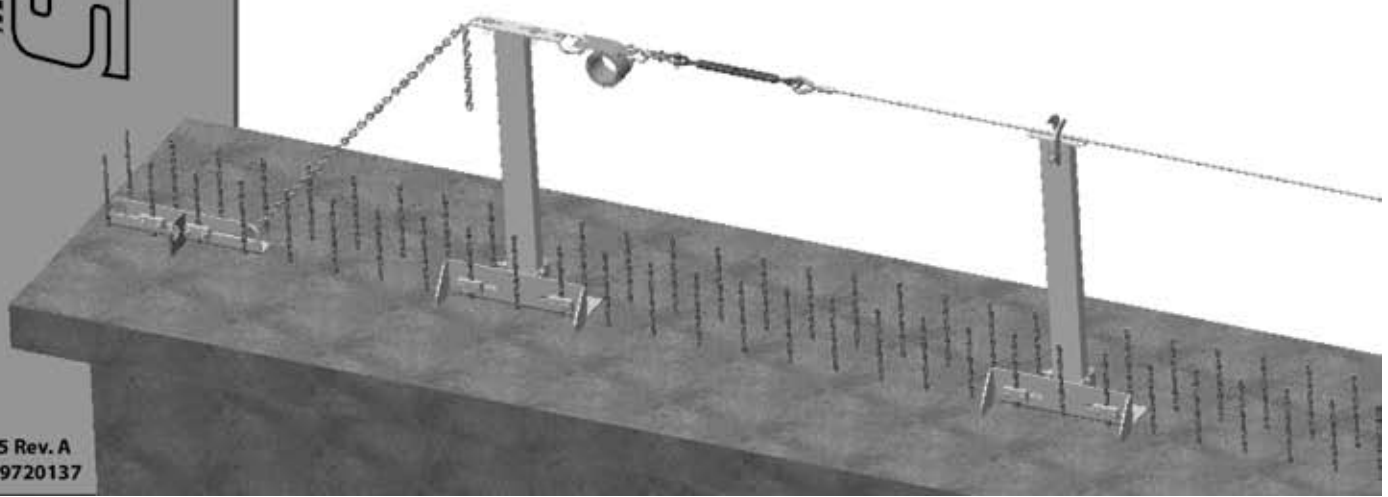

Table of Contents

1.0 Purpose.....	3
2.0 General Requirements, Warnings and Limitations.....	3-4
2.1 General Warnings	
2.2 Limitations	
3.0 System Compatibility.....	4

STEEL APPLICATIONS	4.0 System Diagram and Description of Components for Steel Applications.....	5-6
	5.0 System Requirements for Steel Applications.....	6-7
	5.1 Beam Size Requirements	
	5.2 Beam Load Requirements	
	6.0 Installation for Steel Applications.....	7-11
	6.1 Installation of Stanchion/Base Assembly with Crossbar	
	6.2 Installation of Horizontal Lifeline Assembly	
6.3 Tensioning Horizontal Lifeline		

CONCRETE APPLICATIONS	7.0 System Diagram and Description of Components for Concrete Applications.....	12-13
	8.0 System Requirements for Concrete Applications.....	14-15
	8.1 Rebar, Insert and Anchor Bolt Requirements	
	8.2 Beam Load Requirements	
	9.0 Installation for Concrete Applications.....	15-17
	9.1 Installation of Base, Tie-Back Bracket, Stanchion and Slider Bracket	
	9.2 Installation of Stainless Steel Horizontal Lifeline Assembly	
9.3 Tensioning Horizontal Lifeline		

KITS	10.0 Installation of Horizontal Lifeline Kits.....	17
------	--	----

PERMANENT APPLICATIONS	11.0 Stainless Steel System Diagram and Description of Components for Permanent Applications.....	18
	12.0 Installation of Stainless Steel System for Permanent Applications.....	19-22
	12.1 Installation of D-Bolt Anchor to Beam or Structure	
	12.2 Installation of Horizontal Lifeline Assembly	
	12.3 Tensioning Horizontal Lifeline	

13.0 Operation/Use of Horizontal Lifeline.....	22
14.0 Fall Clearance.....	22-23
15.0 Training.....	24
16.0 Inspection and Maintenance.....	24
Labels.....	25
Inspection and Maintenance Log.....	26
Warranty.....	27

Thank You

We would like to thank you for your purchase of Miller Fall Protection equipment. Miller brand products are produced to meet the highest standards of quality at our ISO 9001:2000 certified facility. Miller Fall Protection equipment will provide you with years of use, if cared for properly.

WARNING

All persons using this equipment must read and understand all instructions. Failure to do so may result in serious injury or death. Do not use this equipment unless you are properly trained.

Questions?

CALL
1.800.873.5242

It is crucial for the owner of this fall protection equipment to read and understand these instructions. In addition, it is also the employer's responsibility to ensure that all users are trained in the proper use, inspection, and maintenance of fall protection equipment. Fall protection training should be an integral part of a comprehensive safety program.

Proper use of fall arrest systems can save lives and reduce the potential of serious injuries from a fall. The user must be aware that forces experienced during the arrest of a fall or prolonged suspension may cause bodily injury. Consult a physician if there is any question about the user's ability to use this product. Pregnant women and minors must not use this product.

1.0 Purpose

The Miller SkyGrip Temporary Horizontal Lifeline (THLL) System is an innovative modular anchorage system designed for steel and concrete applications. Available in single-span and multiple-span systems, the SkyGrip provides workers with continuous fall protection and maximum horizontal mobility. SkyGrip Temporary Horizontal Lifeline Kits and the SkyGrip Stainless Steel System for Permanent Applications offer users additional options for mounting the SkyGrip Horizontal Lifeline (HLL) to approved beams and structures using Miller anchorage connectors.

2.0 General Requirements

2.1 General Warnings

All warnings and instructions shall be provided to authorized persons/users. Warnings and instructions must be read and understood prior to using this equipment.

All authorized persons/users must reference the regulations governing occupational safety, as well as applicable standards.

Proper precautions should always be taken to remove any obstructions, debris, material, or other recognized hazards from the work area that could cause injuries or interfere with the operation of the system.

All equipment must be inspected before each use according to the manufacturer's instructions.

All equipment should be inspected by a qualified person on a regular basis.

To minimize the potential for accidental disengagement, a competent person must ensure system compatibility.

Equipment must not be altered in any way. Repairs must be performed only by the equipment manufacturer, or persons or entities authorized, in writing, by the manufacturer.

Any product exhibiting deformities, unusual wear, or deterioration must be immediately discarded.

Any equipment subject to a fall must be removed from service.

The user shall have a rescue plan and the means at hand to implement it when using this equipment.

Never use fall protection equipment for purposes other than those for which it was designed. Fall protection equipment should never be used for towing or hoisting.

Never remove product labels, which include important warnings and information for the authorized person/user.

2.2 Limitations

Maximum Lifeline Span

The maximum lifeline span between stanchions or anchors is 60ft (18.3m). The system length may be extended by using multiple spans (adding intermediate stanchions or anchors).

Capacity

Maximum capacity is two workers [310lbs (140.6kg) each] per span with a maximum of six workers per multiple-span steel mounted system and five workers per multiple-span concrete mounted system.

System Forces

The SkyGrip HLL System is equipped with an inline energy absorber. In the event of a fall, the unique coil design smoothly expands to limit system forces to 2,500lbf (11.1kN). Multiple-span systems require an energy absorber at both ends of the lifeline.

Note: The Miller SkyGrip HLL must be used with Miller SkyGrip stanchions or Miller approved anchorages that provide a minimum tensile strength of 5,000lbf (22.2kN) or a minimum safety factor of two.

Fall Arrest Forces

In conjunction with the Miller SkyGrip System, workers must use a Miller self-retracting lifeline/fall limiter or a shock-absorbing lanyard, which limits maximum fall arrest force imposed by the worker to 900lbf (4kN).

Free Fall

Personal fall arrest systems must be rigged to limit a free fall to the shortest possible distance [6ft (1.8m) maximum].

Fall Clearance

Ensure that adequate clearance exists in your fall path to avoid striking a lower level or other object (see 14.0 Fall Clearance).

Environmental Hazards

Use of this equipment in areas where environmental hazards exist may require additional precautions to limit the possibility of injury to the user or damage to the equipment. Hazards may include, but are not limited to, high heat, caustic chemicals, corrosive environments, high voltage power lines, explosive or toxic gases, moving machinery, and sharp edges. Polyester should be used in certain chemical or acidic environments. Consult the manufacturer in cases of doubt. All synthetic material must be protected from slag, hot sparks, open flames, or other heat sources. The use of heat resistant materials is recommended in these applications.

3.0 System Compatibility

Miller SkyGrip Systems are designed for use with Miller approved components. Substitution or replacement with non-approved component combinations, sub-systems, or both, may affect or interfere with the safe function of each other and endanger the compatibility within the system. This incompatibility may affect the reliability and safety of the total system.

Miller Fall Protection requires the use of a Miller full-body harness and shock-absorbing lanyard or self-retracting lifeline/fall limiter with this system. All instructions and warnings provided with the body wear and connecting device must be read and understood before using the equipment.

Body Wear

(Full-Body Harness)

WARNING

- **Visually check all buckles to assure proper** and secure connections before each use. All straps must be connected and adjusted to **provide a snug fit.**
- **Fall protection connecting devices should** be attached to the back D-ring of a full-body harness.

- **Side and front D-rings should be used for** positioning only.
- **Shoulder D-rings should be used for retrieval** only.
- **Never attach non-locking snaps to a D-ring.**

Connecting Devices

(Shock-Absorbing Lanyard/Self-Retracting Lifeline/Fall Limiter)

- Make only compatible connections.
- Use only connecting devices containing locking snap hooks or auto-locking carabiners.
- Always visually check that each snap hook and carabiner freely engages the D-ring or anchor point, and that its keeper is completely closed and locked.
- Never disable or restrict locking keeper or alter connecting device in any way.
- Make sure snap hook/carabiner is positioned so that its keeper is never load bearing.
- The use of shock absorbers is required to reduce fall arresting forces. Miller shock absorbers limit maximum fall arrest force to 900 lbs. (4kN).
- Shock absorbers can elongate up to 3-1/2 feet (1.07m). This maximum elongation distance must be considered when choosing an anchor point.
- Tie-off in a manner which ensures a lower level will not be struck should a fall occur.
- Connect in a manner that limits free fall to the shortest possible distance. [6ft. (1.8m) maximum]
- Never rig a two-legged lanyard to create more than a six-foot free fall.
- Never allow a retractable lanyard or lifeline to become slack.
- Never allow a lanyard, or either leg of a two-legged lanyard, to pass under, between or entwine around the user's arms, legs, neck or any other obstacle.
- Do not tie knots in lanyards or lifelines, or wrap around sharp, rough edges, or small diameter structural members.

4.0 System Diagram and Description of Components for Steel Applications

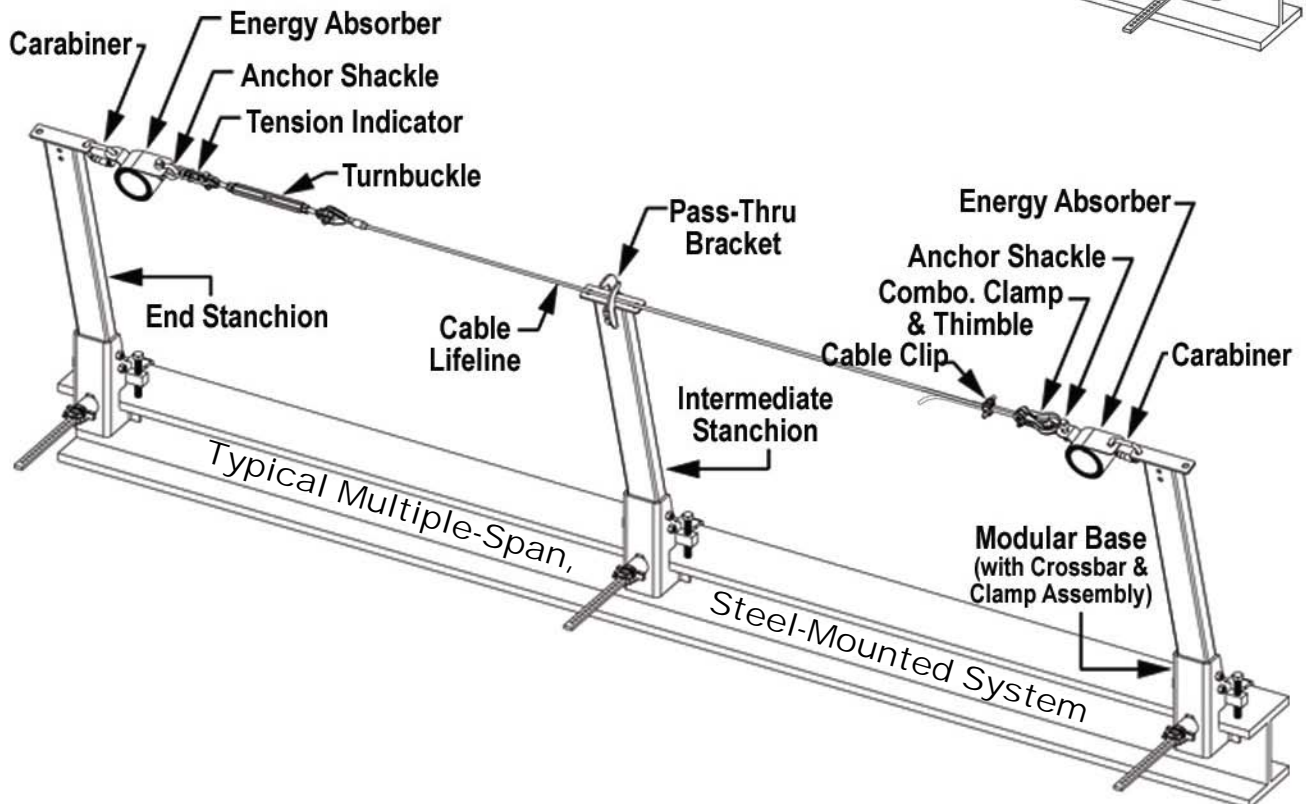
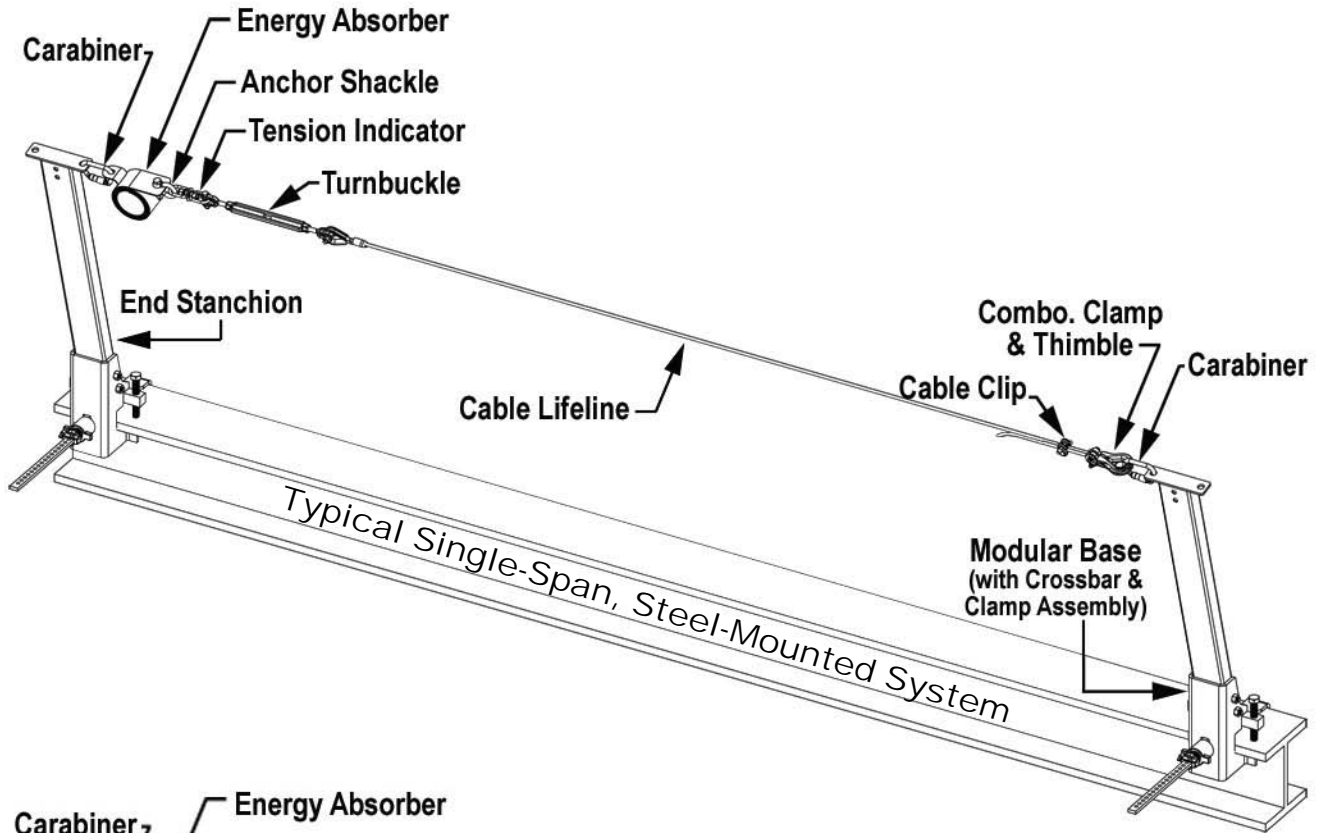

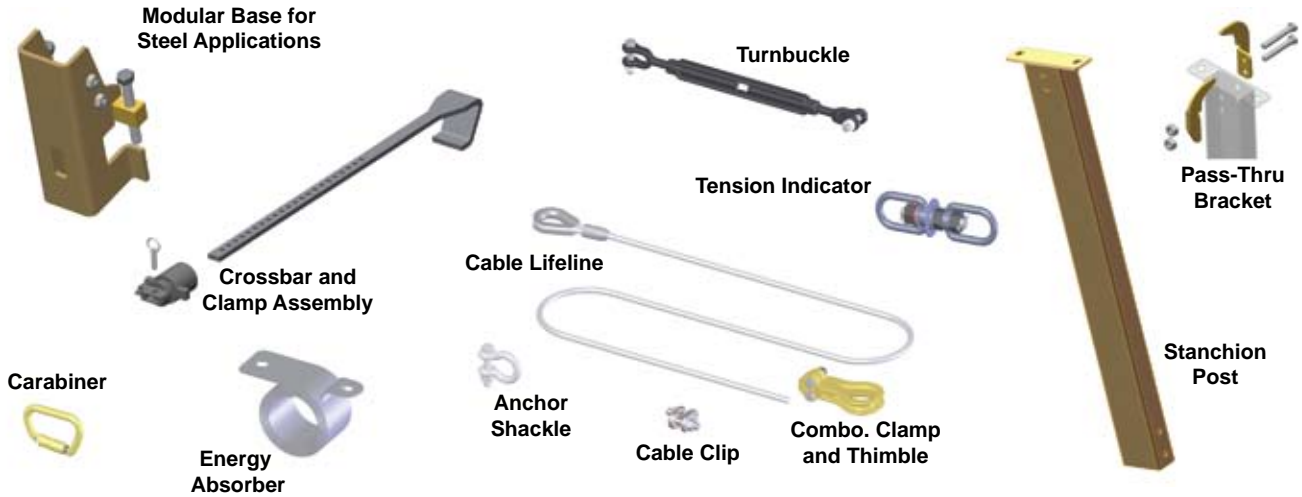

Part No.	Component Name	Qty.	Description
Stanchion/Base Assembly			
SGSB18 or SGSB36	Modular Base	Min. 2*	For steel-mounted system; includes two mounting bolts (3/4" - 10 UNC x 5-1/2" long, fully threaded, grade 8, hex bolt)
SGP	Stanchion Post	Min. 2*	Interchangeable between steel- and concrete-mounted systems; includes two bolts (1/2" - 13 UNC x 5-1/2" long, grade 5 or better) and locknuts
SGSEXT18 or SGSEXT36	Crossbar and Clamp Assembly	Min. 2*	Includes attached installation pin
SGIH	Pass-Thru Bracket Set	Varies*	Includes two bolts (1/2" - 13 UNC x 3-1/4" long) and locknuts
Horizontal Lifeline Assembly			
SGLL	Cable Lifeline	1	3/8" diameter galvanized steel wire rope, 7x19, with thimble at one end
SGTB	Turnbuckle	1	Includes two jaws (5/8" - 11 UNC) with nuts, bolts and cotter pins
<i>Included w/ SGXK</i>	Tension Indicator	1	Includes tension indicator disk
SGAS	Anchor Shackle	1*	7/16" shackle with nut, bolt and cotter pin
SGX	Energy Absorber	Min. 1*	Coiled stainless steel energy absorber
SGCT	Combination Clamp and Thimble	1	Includes two bolts (3/8" - 16 UNC x 1-3/4" long) and nuts
SGW	Cable Clip	1	3/8" double-saddle style wire rope clip
17D-1	Carabiner	2	Steel, auto-locking
*For every intermediate stanchion in a multiple-span system, there will be an additional modular base, stanchion post, and crossbar arm and clamp assembly, as well as a set of pass-thru brackets. In addition, all multiple-span systems require a second energy absorber and an additional anchor shackle.			

5.0 System Requirements for Steel Applications

5.1 Beam Size Requirements

The SkyGrip Temporary Horizontal Lifeline System is designed to be installed on a wide range of steel beams. The unique modular base accommodates beam flange thicknesses up to 2-1/4" (57mm) and widths from 4" (102mm) to 18" (457mm) [Optional large base and crossbar accommodate flange thicknesses from 2-1/4" (57mm) up to 3-3/8" (86mm) and widths from 12" (305mm) to 36" (914mm).]

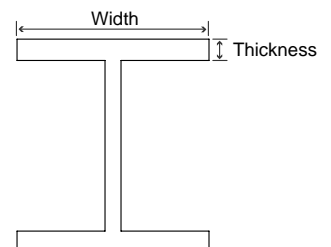

5.2 Beam Load Requirements

The steel beam(s) to which the SkyGrip THLL System is installed must be able to support the potential loads that may be applied in the event of a fall arrest. Stanchion posts may incur horizontal and vertical forces as well as torsional loads. Refer to beam load requirements below. Cumulative loading must be evaluated when more than one system is installed on a beam.

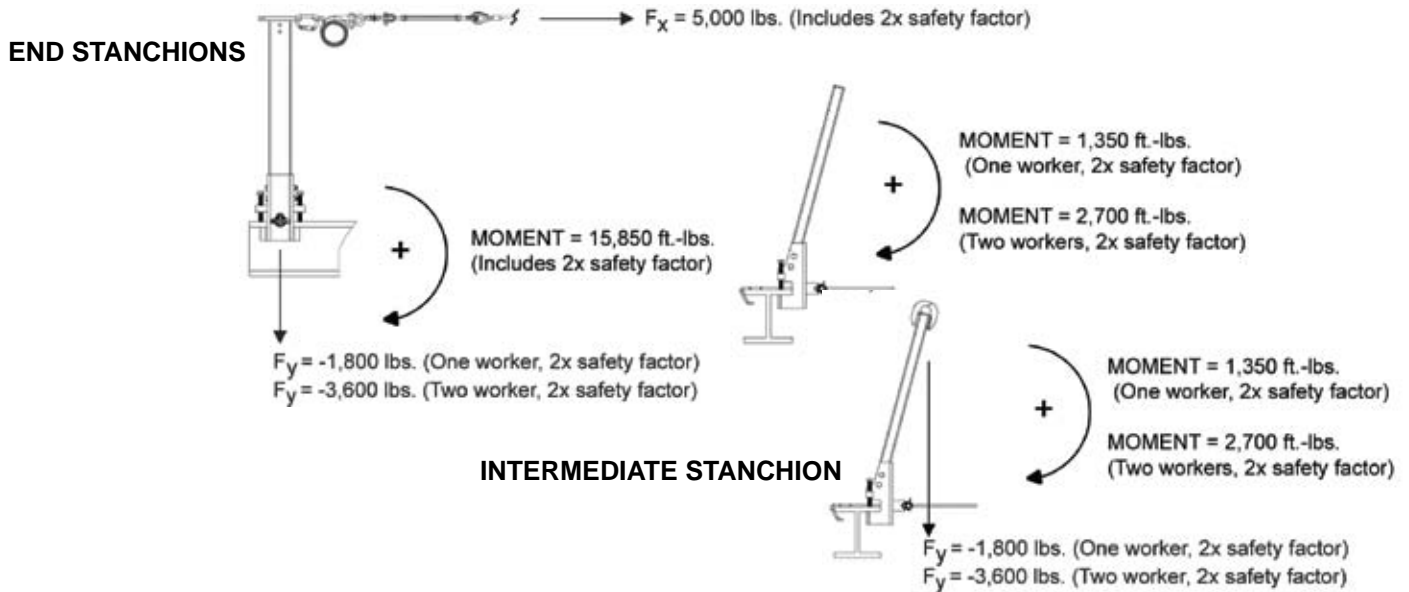

6.0 Installation for Steel Applications

- Before installation, carefully inspect all components of the system according to the manufacturer's instructions (see 16.0 Inspection and Maintenance).
- Ensure that there is sufficient fall clearance below the work surface to avoid hitting a lower level or obstruction (see 14.0 Fall Clearance Requirements).
- If installing the system off-the-ground, a personal fall arrest system including an anchorage connector, such as a Miller beam anchor, must be used. Once a stanchion/base assembly has been completely installed and secured to the beam given the required specifications, a worker may tie-off onto the stanchion.
- Some system components may come preassembled. Installation instructions still must be followed to ensure all components are included and properly assembled. All fasteners and connectors must be checked for correct alignment and installation and tightened to required specifications.

6.1 Installation of Stanchion/Base Assembly with Crossbar

A. Stanchion Post to Modular Base

1. Place stanchion post in base as shown (see Figure 1).
2. Align the holes on the base with the holes in the stanchion post and insert bolts completely. Attach nuts and tighten using a 3/4" wrench and socket.
3. Repeat steps 1 and 2 for each additional end and intermediate stanchion/base assembly.

****The following step only applies to multiple-span systems using intermediate stanchions with pass-thru brackets:**

4. To install pass-thru brackets on intermediate stanchions, align the holes on the pass-thru brackets with those on the stanchion, and insert the bolts completely (see Figure 2). Tighten the bolts snugly using a 3/4" wrench and socket.

Figure 1

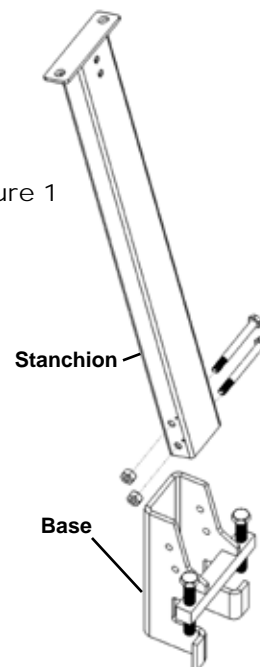
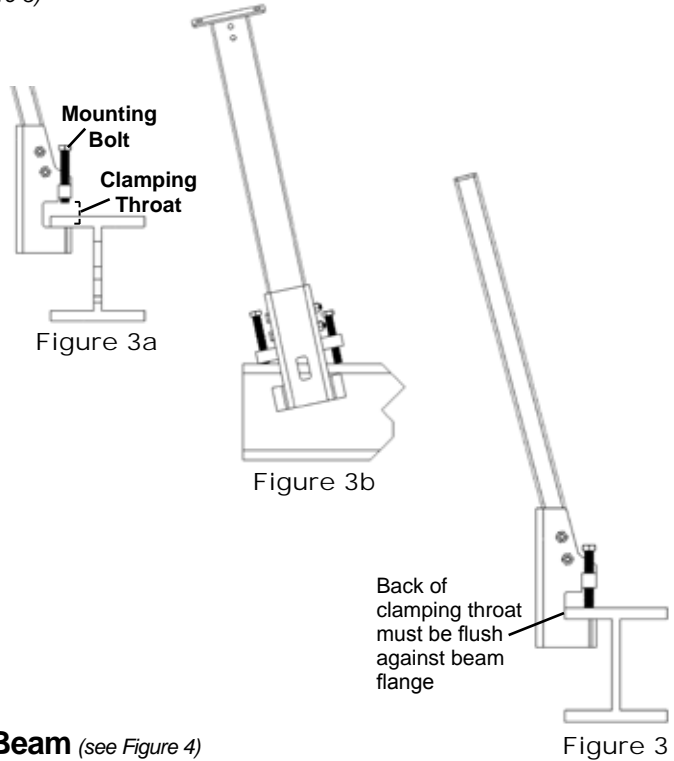

Figure 2

B. Stanchion/Base Assembly to Beam *(see Figure 3)*

1. Unthread mounting bolts on base to maximize space within the clamping throat *(see Figure 3a)* to protect bolt threads. Set stanchion/base assembly on beam.
2. Tilt stanchion/base assembly to one side so that the underlying wing support on the base is touching the beam flange *(see Figure 3b)*. Tighten the mounting bolt by hand. Then tilt the stanchion/base assembly to the opposite side and tighten the remaining bolt by hand. Ensure that the back of the base clamping throat is flush with the beam flange *(see Figure 3)*. Secure bolts with 3/4" wrench but do not fully tighten. Mounting bolts will need to be further tightened once the crossbar and clamp assembly have been installed.



C. Crossbar and Clamp Assembly to Base and Beam *(see Figure 4)*

1. Insert the crossbar through the center hole of the base and hook over beam flange *(see Figures 4a and 4)*. Ensure that the crossbar hook is pushed in tight against the beam flange.
2. Turn nut on clamp assembly until fully closed (the least number of threads showing-see Figure 4b). Then slide the assembly completely onto the crossbar. Locate the nearest hole on the crossbar, which will allow the tightest fit possible, and insert pin.
3. Tighten clamp assembly further by turning the nut.
4. Secure nut by tapping with a hammer.

IMPORTANT: Using an adjustable wrench or 1-1/8" box or open end wrench, now tighten base mounting bolts snugly to beam flange.

Follow these procedures to install stanchion/base assembly with crossbar on opposite end of span and at all intermediate locations.

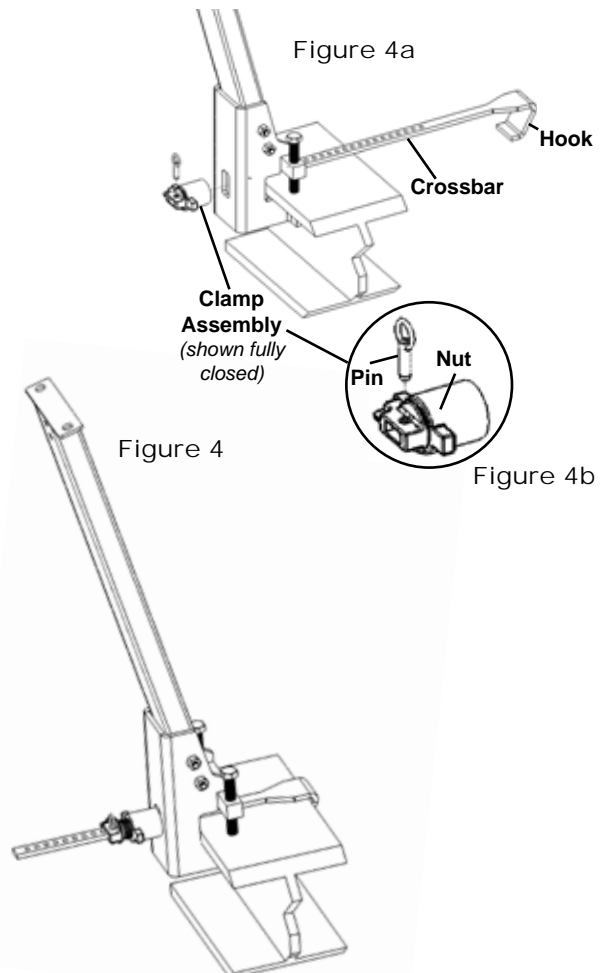

6.2 Installation of Horizontal Lifeline Assembly

WARNING: Always wear gloves when inspecting or installing a cable lifeline.

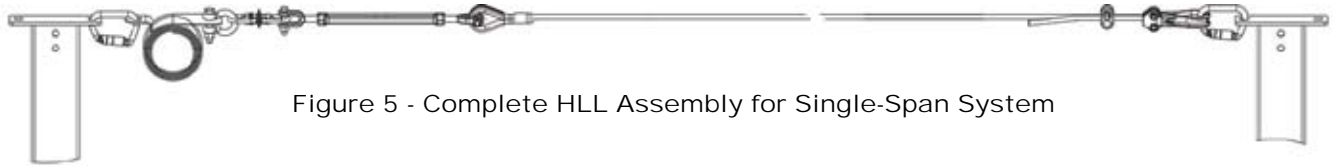

Figure 5 - Complete HLL Assembly for Single-Span System



Figure 6 - Complete HLL Assembly for Multiple-Span System

NOTE: Some components of the horizontal lifeline assembly may come preassembled. Installation instructions still must be followed to ensure all components are included and properly assembled. All fasteners and connectors must be checked for correct alignment and installation and tightened to appropriate torque specifications.

****Procedures A through D apply to the assembly required on the lifeline thimble end.**

A. Shock Absorber Assembly: Shock Absorber to Tension Indicator using Anchor Shackle and Carabiner to Shock Absorber (see Figure 7)

NOTE: The orientation of the shock absorber does not affect the performance of the shock absorber or that of the total system. It is normal for an initial pre-tear of up to 1/2" to be visible. The pre-tear section prevents excessive initial forces in the event of a fall.

1. Remove cotter pin, nut and bolt from anchor shackle.
2. Position anchor shackle through one of the captive eyes on the tension indicator and align the shackle bolt holes with the hole on either end of the shock absorber.
3. Insert bolt completely through shackle and shock absorber, attach nut and tighten snugly using a 3/4" wrench and socket.
4. Insert the cotter pin into the end of the bolt and bend slightly to prevent the pin from backing out.
5. Connect carabiner to opposite end of shock absorber assembly.

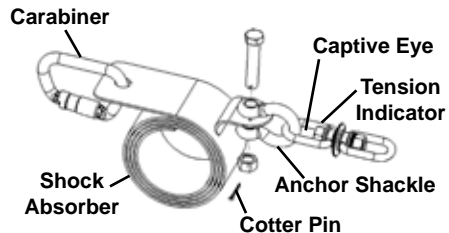

Figure 7

B. Turnbuckle to Lifeline Thimble (see Figure 8)

1. Extend or unthread both turnbuckle jaws (clevis with threaded stud) so that 1/2" of the threads on both jaws are exposed in the turnbuckle body. Doing this will allow for maximum take up of the lifeline slack when tensioning.
2. Remove the cotter pin from the end of one of the jaw bolts. Unscrew the nut and remove the bolt from the turnbuckle jaw.
3. Align the lifeline thimble with the jaw.
4. Insert the bolt through the holes in the jaw, ensuring that it also passes through the lifeline thimble, and screw the nut onto the bolt. Tighten snugly using a 3/4" wrench and socket.
5. Insert the cotter pin into the end of the bolt and bend slightly to prevent the pin from backing out.

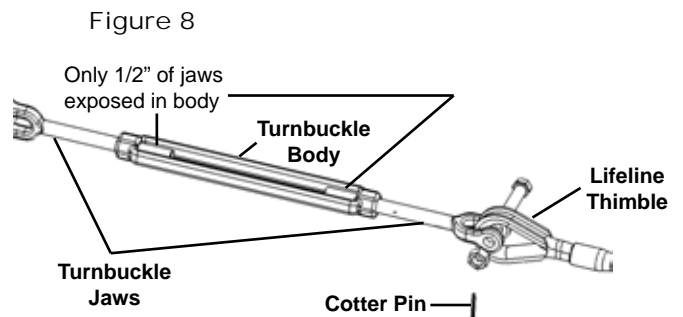

Figure 8

C. Tension Indicator to Turnbuckle *(see Figure 9)*

1. Remove the cotter pin from the end of the jaw bolt. Unscrew the nut and remove the bolt from the turnbuckle jaw.
2. Align the captive eye of the tension indicator with the jaw.
3. Insert the bolt through the holes in the jaw, ensuring that it also passes through the tension indicator eye, attach the nut and tighten snugly with 3/4" wrench and socket.
4. Insert the cotter pin into the end of the bolt and bend slightly to prevent the pin from backing out.

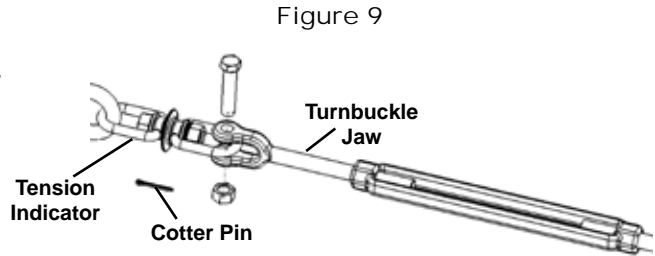

Figure 9

D. Carabiner to Stanchion

1. Connect the shock absorber assembly to the top of the end stanchion using the auto-locking carabiner *(see Figure 10)*.

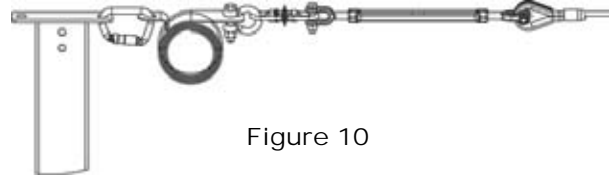

Figure 10

****Procedure E applies to the multiple-span systems using intermediate stanchions with pass-thru brackets.**

E. Cable Lifeline to Pass-Thru Brackets on Intermediate Stanchions *(see Figure 11)*

1. Moving from intermediate stanchion to intermediate stanchion, weave the cable lifeline through each pass-thru bracket.

NOTE: Having the pass-thru brackets in place while installing the lifeline assembly will help to hold the lifeline in position and support its weight.



Figure 11

****Procedures F through H apply to the assembly required on the opposite lifeline end.**

F. Cable Lifeline to Combination Clamp and Thimble *(see Figure 12)* (and Anchor Shackle to Cable Lifeline—*Multiple-Span Systems only*—see Figure 12a)

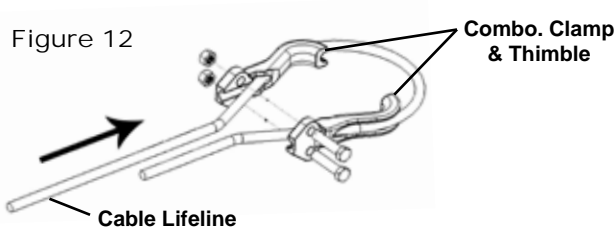

Figure 12

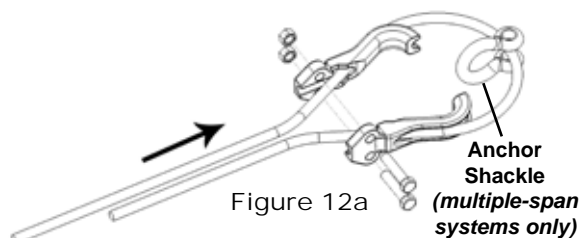

Figure 12a

1. Remove cable clip (if attached) and remove bolts and nuts on combination clamp and thimble.
2. Feed cable through combination clamp and thimble as shown *(see Figure 12)*, taking up as much slack in the lifeline as possible. **(For multiple-span systems be sure to place anchor shackle around cable while feeding the lifeline—see Figure 12a.)**

NOTE: Allow sufficient lifeline to enable attachment of the combination clamp and thimble to the end stanchion: a) using a carabiner (single-span system) OR b) using an anchor shackle/shock absorber/carabiner assembly (multiple-span systems).

3. While holding both sides of the combination clamp and thimble together, ensuring that there is no gap between the two halves, insert the bolts, attach nuts and tighten using 9/16" wrench and socket. Torque to 40 ft.-lbs.

G. Cable Clip to Cable Lifeline *(see Figure 13)*

1. Attach cable clip 2-1/2" from the combination clamp and thimble *(Figure 13)*. Ensure that at least 8" of cable extend beyond the clip. Torque cable clip nuts to 45 ft.-lbs. using a 3/4" wrench.

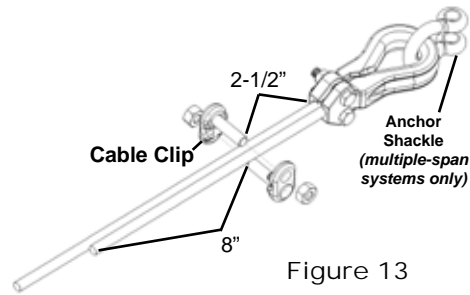

Figure 13

H. Combination Clamp and Thimble to End Stanchion using Carabiner *(Single-Span Systems only – see Figure 14)*

1. Using an auto-locking carabiner, connect the combination clamp and thimble to the top of the end stanchion.

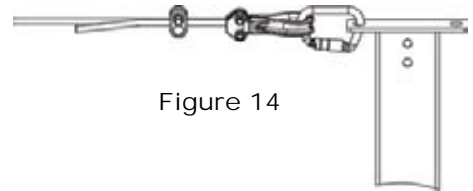

Figure 14

OR

Combination Clamp and Thimble and Shock Absorber to End Stanchion using an Anchor Shackle and Carabiner *(Multiple-Span Systems only – see Figure 15)*

NOTE: Multiple-span systems require a second shock absorber.

1. Position anchor shackle, which is hooked around cable lifeline and combination clamp and thimble, so that shackle bolt holes are aligned with the hole on either end of the shock absorber.
3. Insert bolt completely through shackle and shock absorber, attach nut and tighten snugly using a 3/4" wrench and socket.
4. Insert the cotter pin into the end of the bolt and bend slightly to prevent the pin from backing out.
5. Using a carabiner, connect opposite end of shock absorber to the top of the end stanchion.

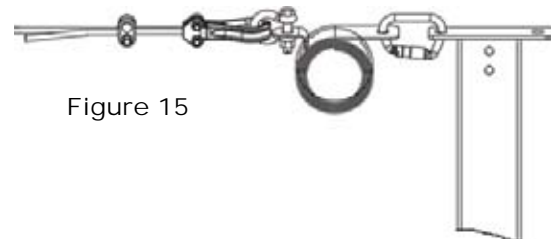

Figure 15

6.3 Tensioning Horizontal Lifeline

IMPORTANT: It is essential that the lifeline be properly tensioned before use. Failure to do so will affect fall clearance requirements and the potential fall forces which may be imposed upon the worker and the system.

1. To prevent the lifeline from twisting while tensioning, hold the turnbuckle jaw at the lifeline thimble end while tightening the turnbuckle body. As the lifeline is tensioned, the jaws (threaded studs) will draw toward one another *(see Figure 16)*.
2. At the correct tension, the tension indicator disk will spin freely by hand.

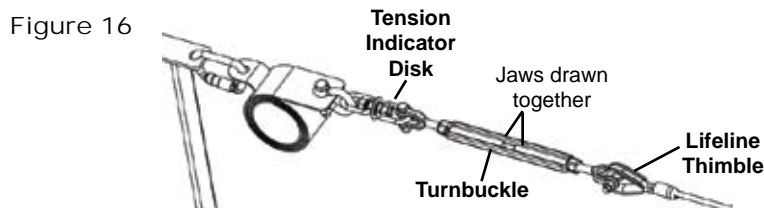
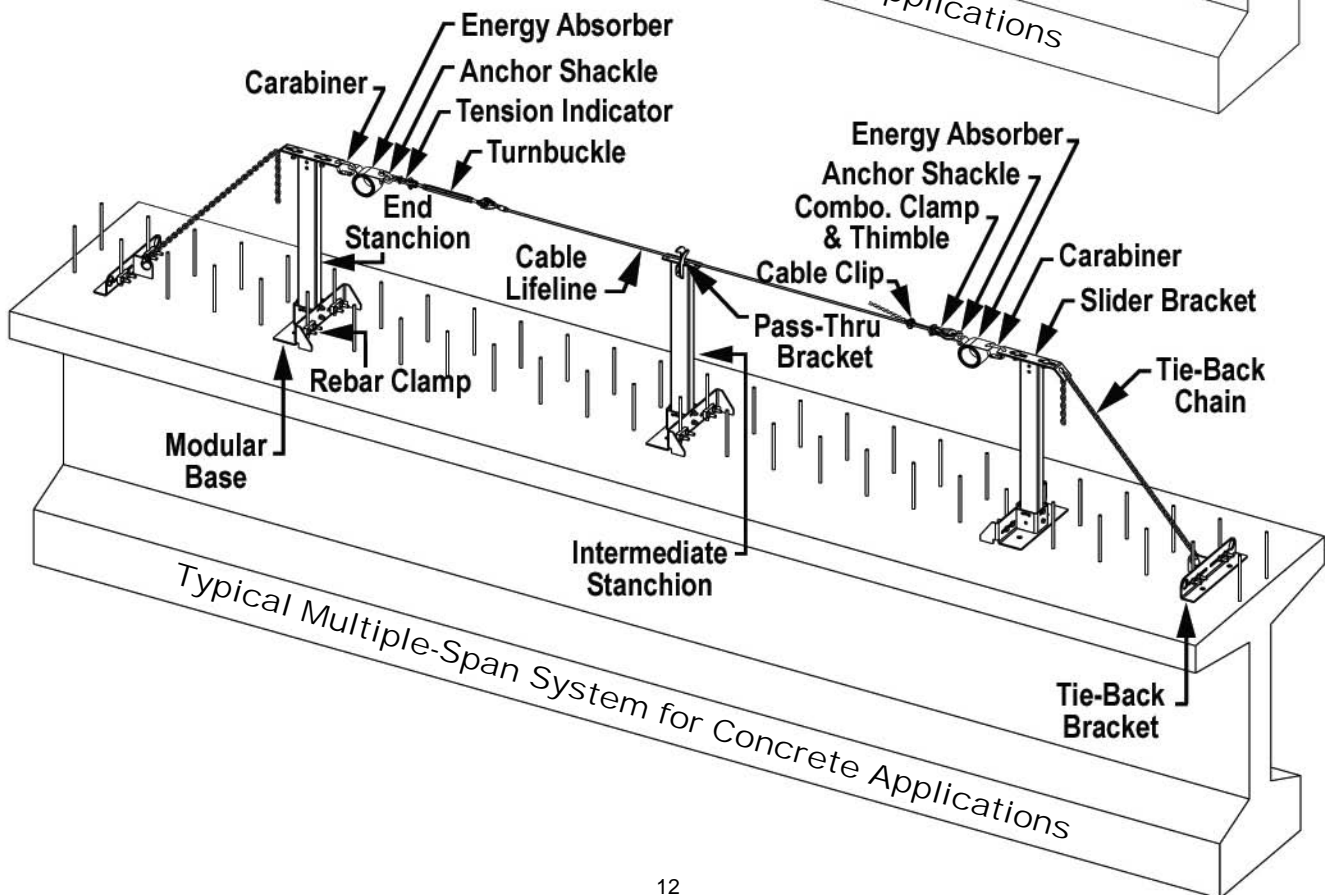
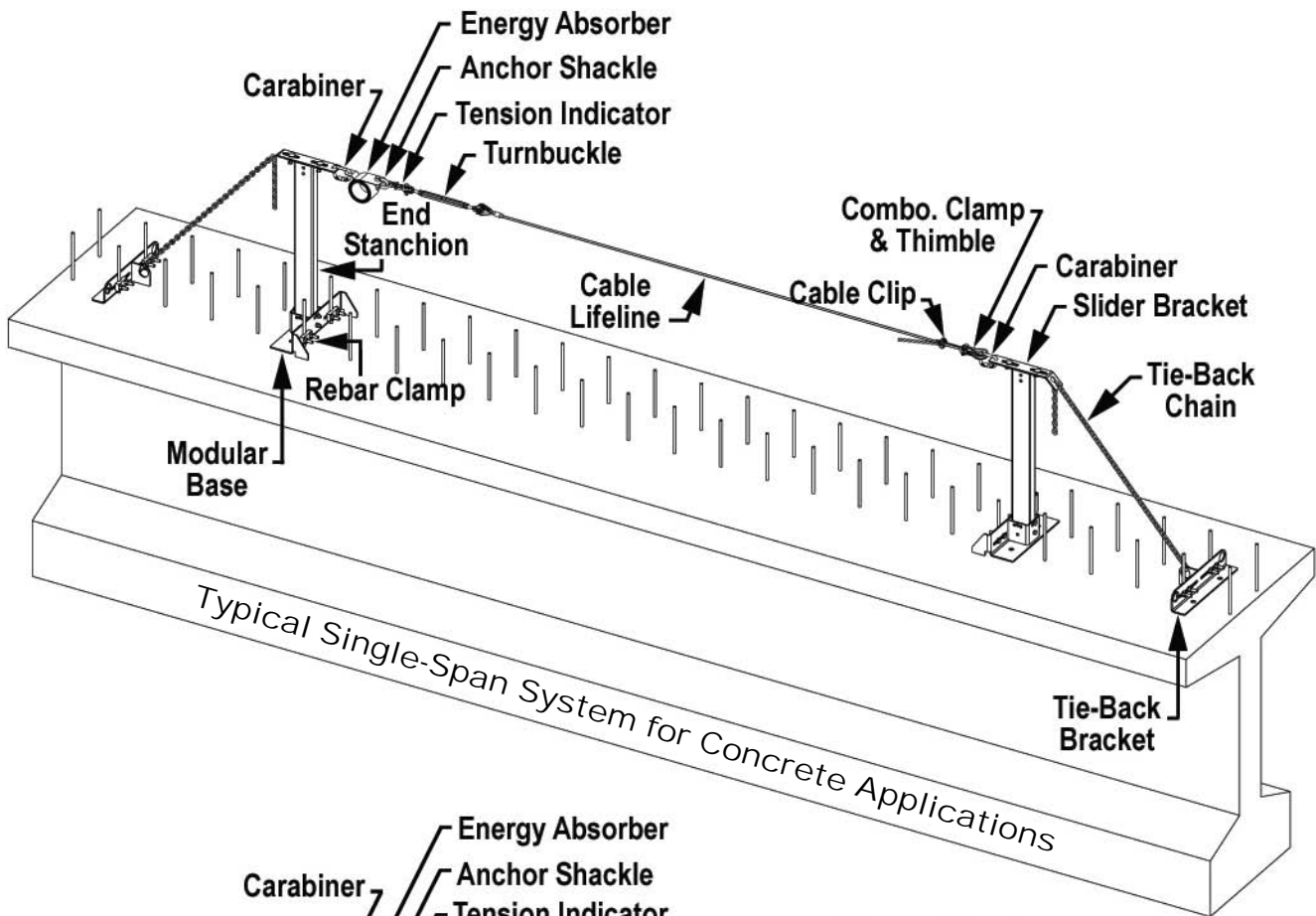
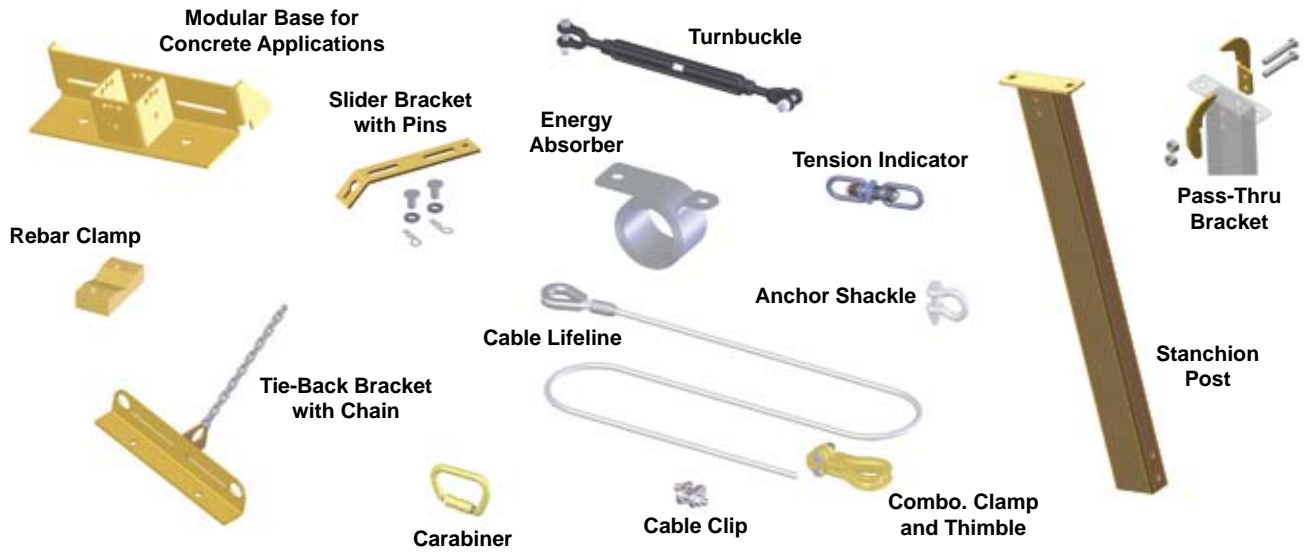

Figure 16

Before using the system, double-check all fasteners to ensure that they are installed correctly and to required specifications. Also, ensure that all connectors within the system are seated properly, closed and locked.

7.0 System Diagram and Description of Components for Concrete Applications





Part No.	Component Name	Qty.	Description
Stanchion/Base Assembly			
SGCB	Modular Base	Min. 2*	For concrete-mounted system
SGCA	Tie-Back Bracket	2	For concrete-mounted system: includes tie-back chain (grade 80), chain connector component and hex bolt (5/16" -18 UNC x 1-1/4" long) and locknut
<i>Part of SGCA</i>	Slider Bracket	2	Includes two stainless steel pins with 3/4" washers and wire pins
<i>Included w/ SGCB & SGCA</i>	Rebar Clamp/V-Grip	Min. 8**	Includes two bolts (1/2" - 13 UNC x 3-1/2" long, fully-threaded, grade 8)
SGP	Stanchion Post	Min. 2*	Interchangeable between steel- and concrete-mounted systems; includes two bolts (1/2" - 13 UNC x 5-1/2" long, grade 5 or better) and locknuts
SGIH	Pass-Thru Bracket Set	Varies*	Includes two bolts (1/2" - 13 UNC x 3-1/4" long) and locknuts
Horizontal Lifeline Assembly			
SGLL	Cable Lifeline	1	3/8" diameter galvanized steel wire rope, 7x19, with thimble at one end
SGTB	Turnbuckle	1	Includes two jaws (5/8" - 11 UNC) with nuts, bolts and cotter pins
<i>Included w/ SGXX</i>	Tension Indicator	1	Includes tension indicator disk
SGAS	Anchor Shackle	1*	7/16" shackle with nut, bolt and cotter pin
SGX	Energy Absorber	Min. 1*	Coiled stainless steel energy absorber
SGCT	Combination Clamp and Thimble	1	Includes two bolts (3/8" - 16 UNC x 1-3/4" long) and nuts
SGW	Cable Clip	1	3/8" double-saddle style wire rope clip
17D-1	Carabiner	2	Steel, auto-locking
<p>*For every intermediate stanchion in a multiple-span system, there will be an additional modular base and stanchion post, as well as a set of pass-thru brackets. In addition, all multiple-span systems require a second shock absorber and an additional anchor shackle.</p> <p>**Rebar clamps are only required if securing system to rebar. In addition to the eight rebar clamps required to install base and tie-back brackets at each end of the system, there will be two rebar clamps required for each intermediate stanchion.</p>			

8.0 System Requirements for Concrete Applications

8.1 Rebar, Insert and Anchor Bolt Requirements

The SkyGrip Temporary Horizontal Lifeline System is designed to be installed on precast concrete beams by securing to rebar or to coil inserts. It is also designed for installation to flat concrete surfaces where concrete expansion anchor bolts may be used to secure the system.

Rebar Spacing and Size Requirements

The concrete mounting base and tie-back bracket are designed to be installed to rebar in straight, L-shaped, and U-shaped configurations with varied spacing.

Requirements: Size 4 (1/2" diameter) to 11 (1-3/8" diameter)
 Min. 8" rebar spacing; max. 13" rebar spacing for modular base
 Min. 4" rebar spacing; max. 12" rebar spacing for tie-back bracket
 Refer to diagrams below. (All dimensions are in inches.)

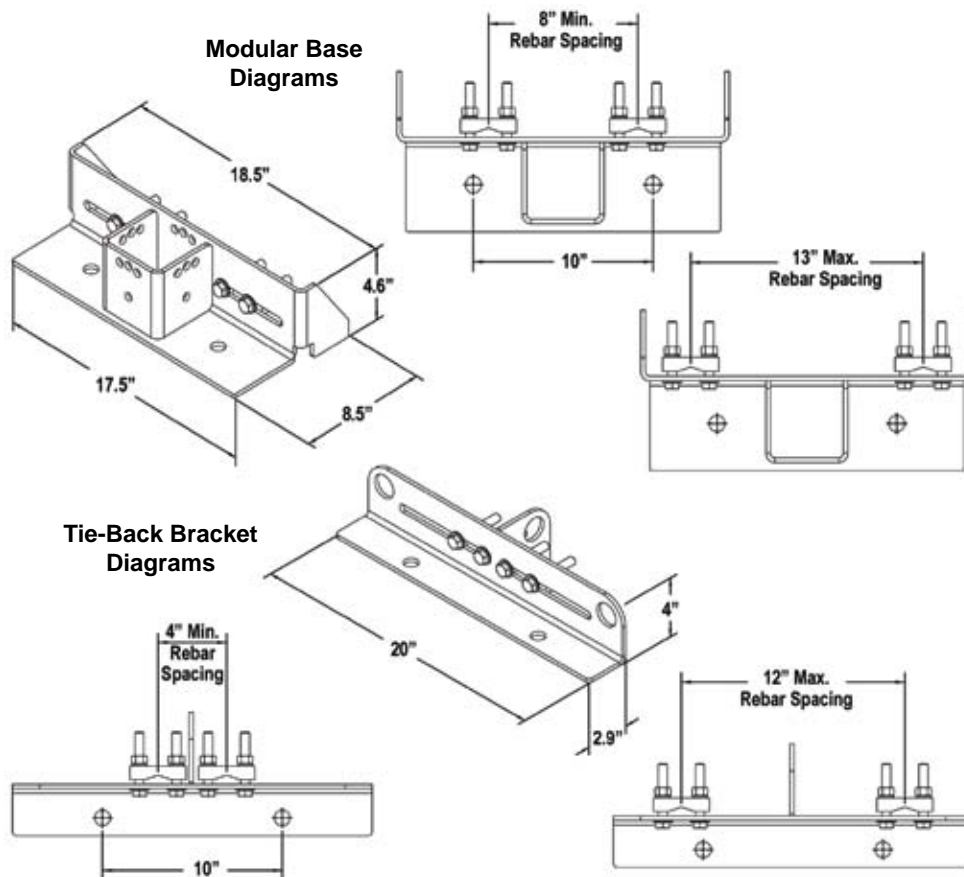

Coil Insert Requirements

Another option is to install the concrete mounting base and tie-back bracket using coil inserts, such as the Dayton/Richmond (Dayton/Superior) B-18 Single-Flared Coil Inserts.

Requirements: 3/4" x 9" coil inserts
 Refer to spacing and dimension diagrams on page 17.

Manufacturer's instructions, installation procedures, and required specifications for coil inserts must be followed.

Concrete Expansion Anchor Bolt Requirements

The concrete mounting base and tie-back bracket may also be installed using concrete expansion anchor bolts, such as the Hilti Kwik Bolt 3 Expansion Anchor, 3/4" x 4-3/4" length (Item No. 282517). This is a plated, carbon-steel 3/4-10 UNC bolt with 1-1/2" thread length.

Manufacturer's instructions, installation procedures, and required specifications for concrete expansion anchor bolts must be followed.

8.2 Beam Load Requirements

The precast concrete beam(s) to which the SkyGrip THLL System is installed must be able to support the potential loads that may be applied in the event of a fall arrest. Stanchion posts and tie-back brackets may incur horizontal and vertical forces as well as torsional loads. Refer to beam load requirements in charts below. Cumulative loading must be evaluated when more than one system is installed on a beam.

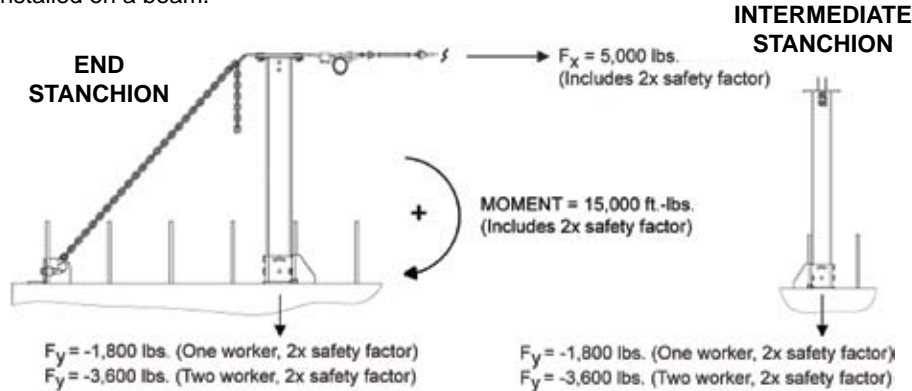

9.0 Installation for Concrete Applications

- Before installation, carefully inspect all components of the system according to the manufacturer's instructions (see 16.0 Inspection and Maintenance).
- Ensure that there is sufficient fall clearance below the work surface to avoid hitting a lower level or obstruction (see 14.0 Fall Clearance Requirements).
- If installing the system off-the-ground, a personal fall arrest system including an anchorage connector, such as a Miller beam anchor, must be used. Once a stanchion/base assembly has been completely installed and secured to the beam given the required specifications, a worker may tie-off onto the stanchion.
- Some system components may come preassembled. Installation instructions still must be followed to ensure all components are included and properly assembled. All fasteners and connectors must be checked for correct alignment and installation and tightened to required specifications.

9.1 Installation of Base, Tie-Back Bracket, Stanchion and Slider Bracket

A. Base and Tie-Back Bracket to Concrete

1. Select one of the installation configurations shown.

NOTE: When setting the base and tie-back bracket using the perpendicular configuration, the orientation of the two components must be exactly as shown. For the parallel configuration, the base and bracket may be oriented in either direction.

2. For installation to rebar (see Figure 17): Place base and tie-back bracket on concrete beam a minimum of 36" apart from mounting rebar to mounting rebar in the chosen configuration. Both the base and bracket must be flush against two sections of rebar, aligning the rebar within the slotted openings. Install rebar clamps as shown. Secure each of the four rebar clamps to the rebar and base or tie-back bracket using the bolts, washers and nuts. Torque to 75ft.-lbs.

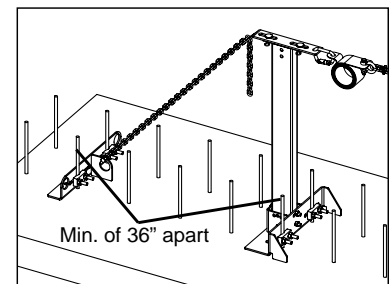

Perpendicular Configuration

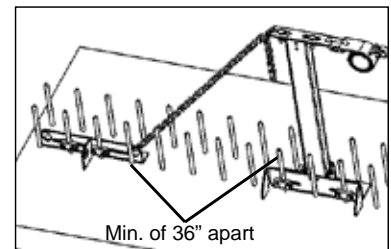

Parallel Configuration

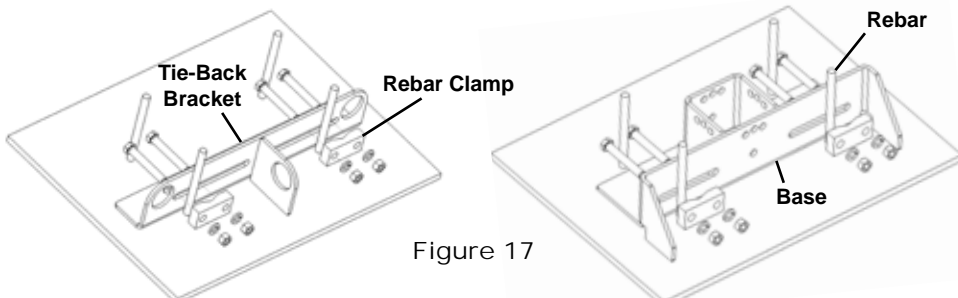

Figure 17

[For installation using coil inserts or concrete expansion anchor bolts: Install base and tie-back bracket on concrete beam a minimum of 36" apart in the chosen configuration, aligning the holes on the bottom of the base and bracket with the holes in the concrete. Follow manufacturer's instructions for inserts or anchor bolts.]

B. Stanchion Post to Base *(see Figure 18)*

NOTE: Stanchion posts are installed in base relative to base and tie-back bracket configuration chosen.

1. Position stanchion inside square receiver on base. Stanchion post may stand straight vertically or it may be installed at an angle *(see Figure 18a)*. Align the holes on the stanchion post and base receiver and secure with the bolts and nuts. Tighten snugly using a 3/4" wrench and socket.

Figure 18

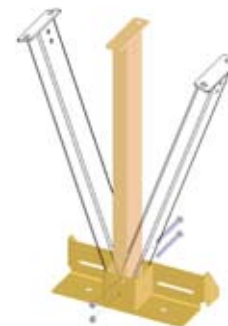
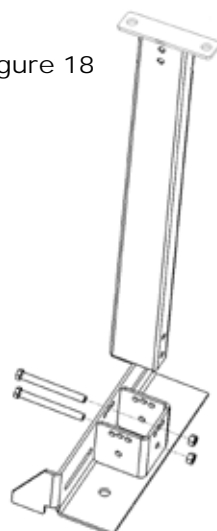

Figure 18a

C. Slider Bracket to End Stanchion and Connection to Tie-Back Bracket *(see Figure 19)*

1. Set slider bracket on top of stanchion post with angled end directed toward tie-back bracket.
2. Connect slider bracket to stanchion using only the approved pins including washers and wire pins *(see Figure 19a)*. Bracket should be enabled to slide back and forth on the post.
3. Position slider bracket as far toward the tie-back bracket as allowed by pins and insert chain down through the hole on the slider bracket. Take up as much slack as possible and secure by fully inserting a chain link into the slot *(see Figure 19b; min. 3-link overhang required)*.

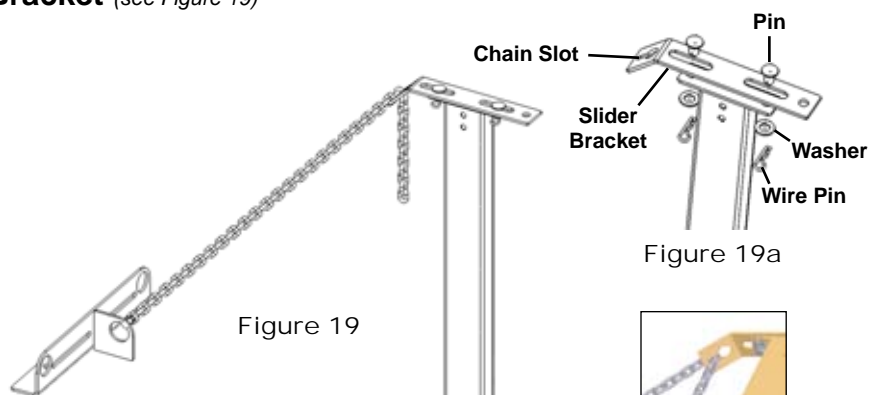

Figure 19

Figure 19a



Figure 19b

NOTE: Depending on the installation configuration chosen, the chain may need to be connected to a different hole on the tie-back bracket. Refer to *Figures 19c and 19d* for using the chain connector component.

Figure 19c



Figure 19d



Follow these procedures to install stanchion/base assembly with slider and tie-back brackets on opposite end of span. Intermediate locations in multiple-span systems require the stanchion/base assembly only (no brackets). For instructions on installing pass-thru brackets on intermediate stanchions, refer to [section 6.1, procedure A, step 4 on page 9](#).

9.2 Installation of Horizontal Lifeline Assembly

Install complete Horizontal Lifeline Assembly as described in [section 6.2 \(pages 11-14\), procedures A through H only](#).

[EXCEPTION: The lifeline assembly attaches to the slider brackets which sit on top of the end stanchions as opposed to the end stanchions themselves.]

9.3 Tensioning Horizontal Lifeline

IMPORTANT: It is essential that the lifeline be properly tensioned before use. Failure to do so will affect fall clearance requirements and the potential fall forces which may be imposed upon the worker and the system.

Figure 20

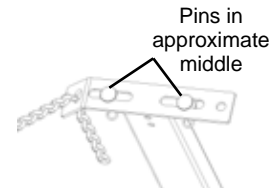
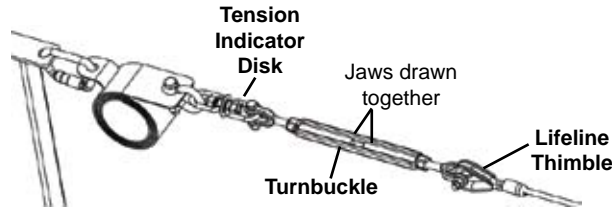

Figure 20a

1. To prevent the lifeline from twisting while tensioning, hold the turnbuckle jaw at the lifeline thimble end while tightening the turnbuckle body. As the lifeline is tensioned, the jaws (threaded studs) will draw toward one another (see Figure 20).
NOTE: This tensioning should take up any slack in the tie-back chains and will cause the slider brackets to shift away from the tie-back brackets. After tensioning, slider brackets should not be pushed completely to one end or the other; pins should be located in the approximate middle of the slots on the slider bracket (see Figure 20a).
2. At the correct tension, the tension indicator disk will spin freely by hand.

Before using the system, double-check all fasteners to ensure that they are installed correctly and to required specifications. Also, ensure that all connectors within the system are seated properly, closed and locked.

10.0 Installation of Horizontal Lifeline Kits

1. Install Miller approved anchorage connectors according to the instructions provided with the anchorage connector. (For horizontal installation of a cross-arm strap, see Figure 21a.)
2. Install complete Horizontal Lifeline Assembly as described in section 6.2, procedures A through C (lifeline thimble end) and F and G (opposite lifeline end) on pages 11-13.
3. Using the auto-locking carabiners, connect each end of the horizontal lifeline to the installed anchorage connectors.
4. Refer to section 6.3 on page 14 for procedures on tensioning the horizontal lifeline.

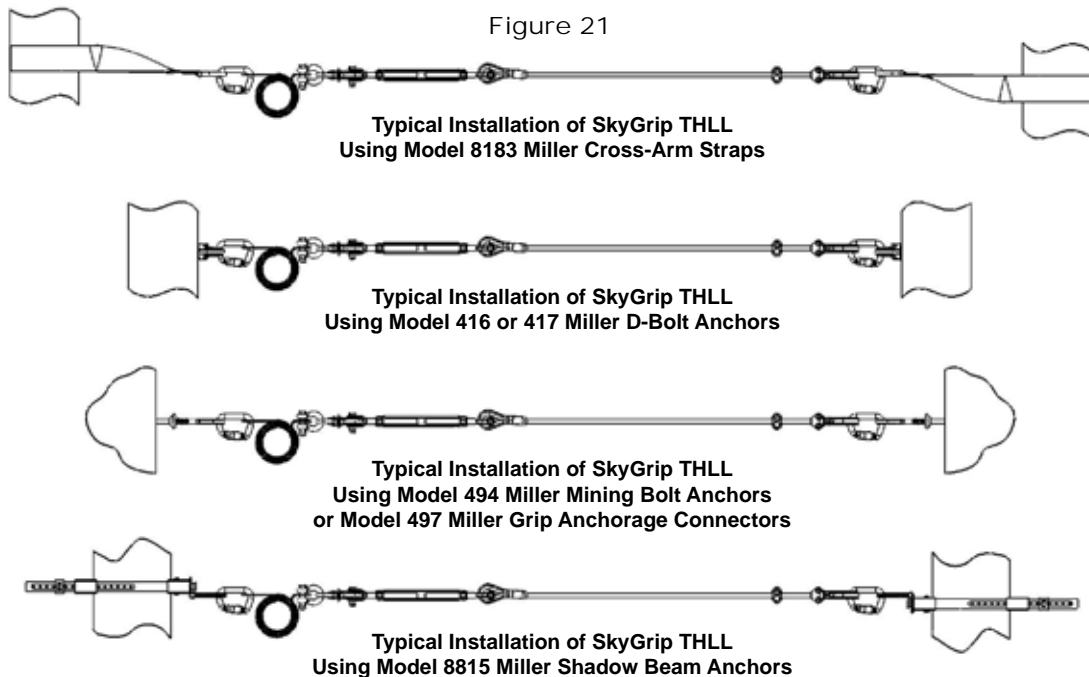

Figure 21

Typical Installation of SkyGrip THLL
Using Model 8183 Miller Cross-Arm Straps

Typical Installation of SkyGrip THLL
Using Model 416 or 417 Miller D-Bolt Anchors

Typical Installation of SkyGrip THLL
Using Model 494 Miller Mining Bolt Anchors
or Model 497 Miller Grip Anchorage Connectors

Typical Installation of SkyGrip THLL
Using Model 8815 Miller Shadow Beam Anchors

Horizontal Installation of Cross-Arm Strap

Wrap cross-arm strap around approved anchorage point. To prevent slippage, wrap cross-arm strap around anchorage point as many times as possible.

The 2" (50mm) D-ring must pass completely through the 3" D-ring (76mm).



NOTE: Shown with Cross-Arm Strap Model 8185 (w/D-ring and loop) rather than Model 8183 (w/two D-rings).

11.0 Stainless Steel System Diagram and Description of Components for Permanent Applications

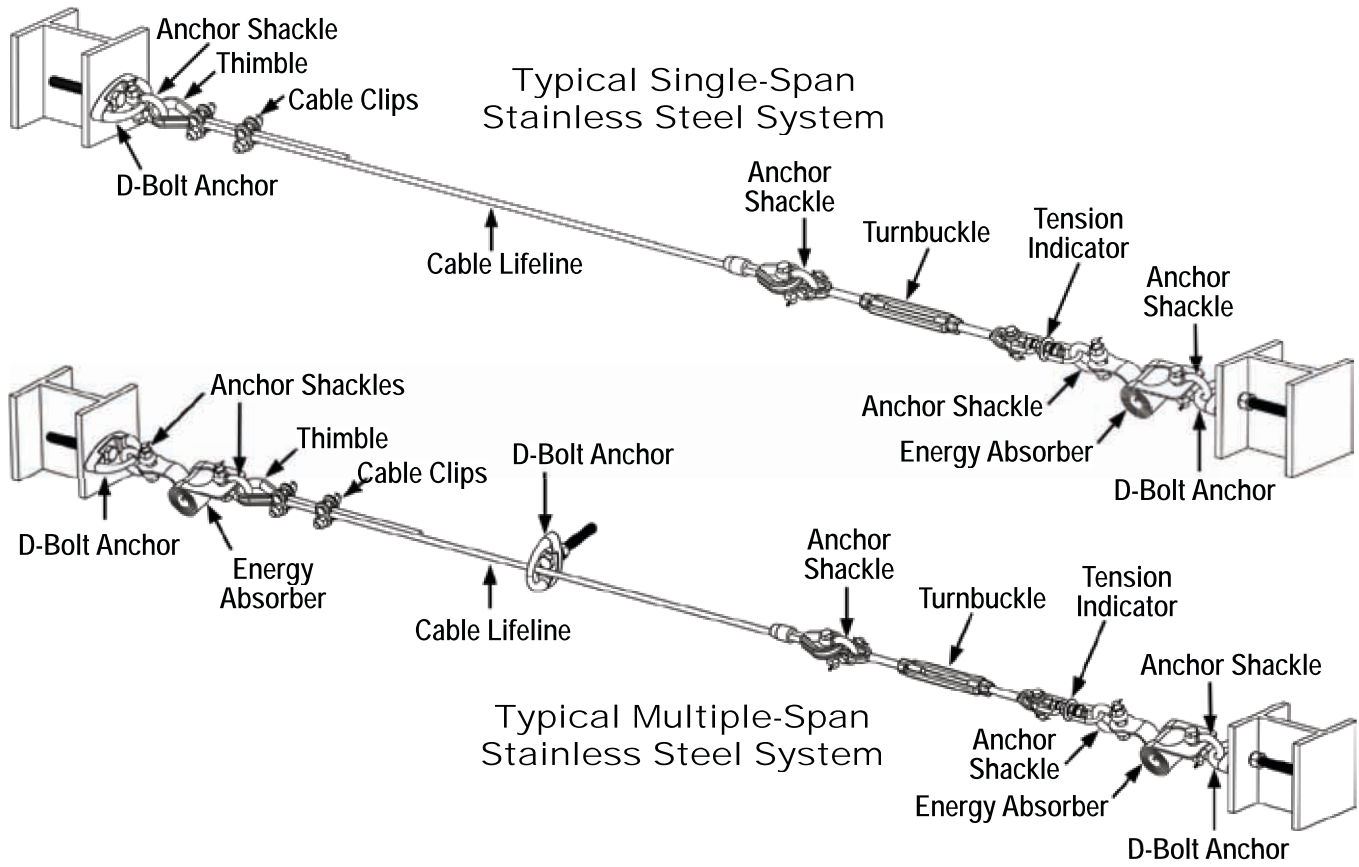

Part No.	Component Name	Qty.	Description
Stainless Steel System			
416SS	D-Bolt Anchor	2*	5/8" stainless steel D-anchor with hex bolt (5/8" - 11 UNC x 5"), hex nut and split lockwasher
417SS	D-Bolt Anchor	2*	5/8" stainless steel D-anchor (<i>Fasteners not included--The 417 D-Bolt Anchor must only be used with an approved 5/8" - 11 UNC hex bolt, hex nut and split lockwasher.</i>)
SGLL-SS	Cable Lifeline	1	3/8" diameter stainless steel wire rope, 7x19, with thimbles
SGW-SS	Cable Clip	3	3/8" double-saddle style wire rope clip
SGTB-SS	Turnbuckle	1	Includes two 1/2" jaws with nuts, bolts and cotter pins
<i>Included w/ SGXK-FS</i>	Tension Indicator	1	Stainless Steel tension indicator includes tension indicator disk
SGAS-SS	Anchor Shackle	4**	7/16" stainless steel shackle with nut, bolt and cotter pin
SGX	Energy Absorber	1**	Coiled stainless steel energy absorber

*The stainless steel system will either include the 416SS or the 417SS, depending on the installation application and corresponding system ordered. Multiple-span systems will include additional D-bolt anchors, depending on the length of the system.
 **Multiple-span systems include an additional anchor shackle and energy absorber.

12.0 Installation of Stainless Steel System for Permanent Applications

- Before installation, carefully inspect all components of the system according to the manufacturer's instructions (see 16.0 Inspection and Maintenance).
- Ensure that there is sufficient fall clearance below the work surface to avoid hitting a lower level or obstruction (see 14.0 Fall Clearance Requirements).
- If installing the system off-the-ground, a personal fall arrest system including an anchorage connector, such as a Miller beam anchor, must be used. Once a D-bolt anchor has been completely installed and secured to the beam or structure given the required specifications, a worker may tie-off onto the anchor.
- Some system components may come preassembled. Installation instructions still must be followed to ensure all components are included and properly assembled. All fasteners and connectors must be checked for correct alignment and installation and tightened to required specifications.

12.1 Installation of D-Bolt Anchor to Beam or Structure

NOTE: 416 D-Bolt Anchor shown; 417 D-Bolt Anchor does not include fasteners.

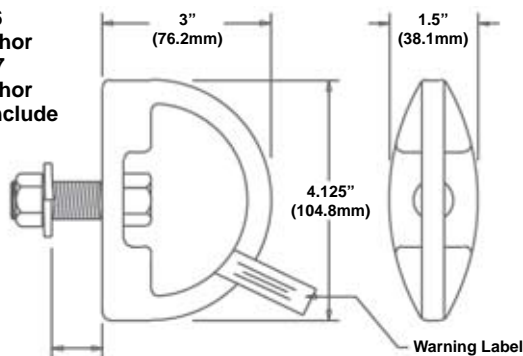

Working Thickness up to 4" (101.6mm)
 [417 D-Bolt Anchor can be mounted with a longer 5/8" bolt to accommodate greater thicknesses.]

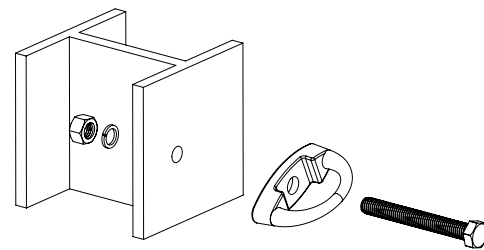
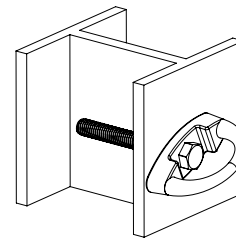

Figure 22



1. Locate and identify an approved compatible anchorage. The beam or structure that this product is attached to must be capable of supporting a 5,000 lb. (22.2kN) static load or provide a 2:1 safety factor in the direction of pull. Be sure that the mounting location is clean and free of debris.
2. Locate or drill a 21/32" diameter hole. Consideration should be given to allow sufficient clearance to place the lockwasher and tighten the nut.

WARNING: On D-bolts installed to W-Shaped beams (see Fig. 22a), the mounting hole must be drilled perpendicular to the flange. D-bolts installed to S-Shaped beams (see Fig. 22b) must be drilled perpendicular to the flange and a tapered (aka bevel, side hill or wedge) washer must be used to ensure the D-bolt and/or nut and washer seats squarely against the beam surface.

3. Mount the D-Bolt Anchor by passing the approved 5/8" stainless steel bolt through the hole in the connector and through the hole in the structure (see Figure 22). Attach the lockwasher and nut. Completely tighten making sure the entire nut is engaged on the threads and the device is securely fastened to the structure. Torque to 125 ft. lbs.

WARNING: Do not overtighten. Excessive tension can cause damage to the anchorage system. Use recommended torque value above.

Fig. 22a
W-Shape (Wide Flange)

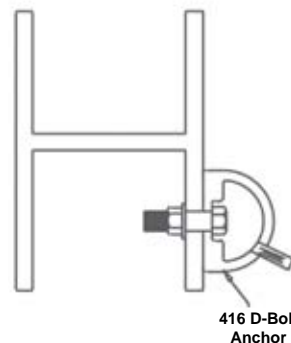
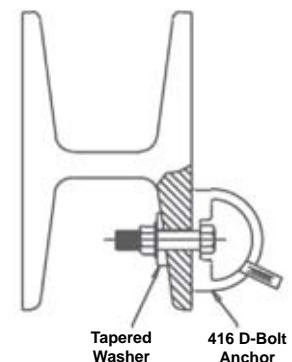

Fig. 22b
S-Shape (Structural I-Beam)



Follow these procedures to install D-bolt anchor on opposite end of span and at all intermediate locations, if applicable.

12.2 Installation of Stainless Steel Horizontal Lifeline Assembly

WARNING: Always wear gloves when inspecting or installing a cable lifeline.

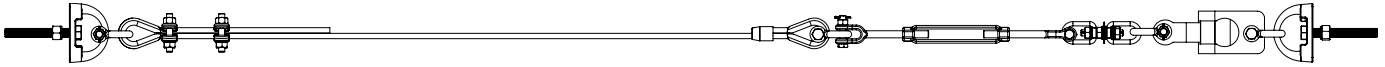

Figure 23 - Complete Stainless Steel HLL Assembly for Single-Span System



Figure 24 - Complete Stainless Steel HLL Assembly for Multiple-Span System

NOTE: Some components of the horizontal lifeline assembly may come preassembled. Installation instructions still must be followed to ensure all components are included and properly assembled. All fasteners and connectors must be checked for correct alignment and installation and tightened to appropriate torque specifications.

****Procedures A and B apply to the assembly required on the lifeline end with the manufacturer installed thimble.**

A. Shock Absorber to Tension Indicator and D-Bolt Anchor using Anchor Shackles (see Figure 25)

NOTE: The orientation of the shock absorber does not affect the performance of the shock absorber or that of the total system. It is normal for an initial pre-tear of up to 1/2" to be visible. The pre-tear section prevents excessive initial forces in the event of a fall.

1. Remove cotter pin, nut and bolt from anchor shackle.
2. Position anchor shackle through one of the captive eyes on the tension indicator and align the shackle bolt holes with the hole on either end of the shock absorber.
3. Insert bolt completely through shackle and shock absorber, attach nut and tighten snugly using a 3/4" wrench and socket.
4. Insert the cotter pin into the end of the bolt and bend slightly to prevent the pin from backing out.
5. Connect other anchor shackle to opposite end of shock absorber assembly and to D-bolt anchor using the same procedure.

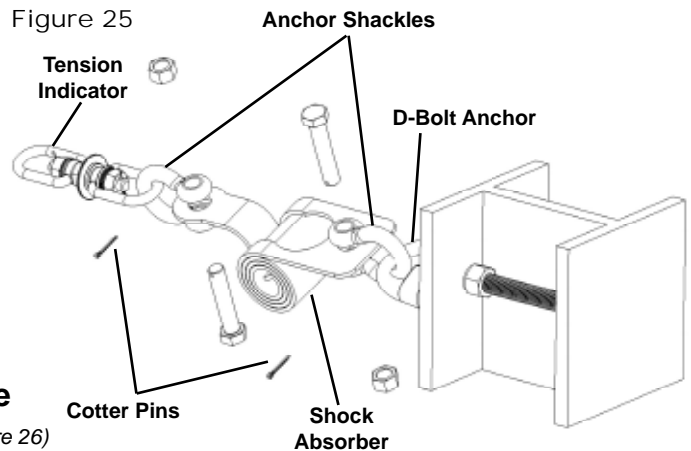

B. Turnbuckle to Tension Indicator and Lifeline Swaged Thimble using Anchor Shackle (see Figure 26)

1. Extend or unthread both turnbuckle jaws (clevis with threaded stud) so that 1/2" of the threads on both jaws are exposed in the turnbuckle body. Doing this will allow for maximum take up of the lifeline slack when tensioning.
2. Remove the cotter pin from one end of the jaw bolt. Unscrew the nut and remove the bolt from the turnbuckle jaw.
3. Align the captive eye of the tension indicator with the jaw, and insert the bolt through the holes in the jaw, ensuring that it also passes through the tension indicator eye. Attach the nut and tighten snugly with 3/4" wrench and socket.
4. Insert the cotter pin into the end of the bolt and bend slightly to prevent the pin from backing out.
5. Remove cotter pin, nut and bolt from anchor shackle.
6. Position anchor shackle through other turnbuckle jaw and align the shackle bolt holes with the lifeline swaged thimble. **(Note: It may be necessary to remove turnbuckle jaw fasteners to position shackle, then reattach and tighten snugly.)**
7. Insert bolt completely through shackle and thimble, attach nut and tighten snugly using a 3/4" wrench and socket.
8. Insert the cotter pin into the end of the bolt and bend slightly to prevent the pin from backing out.

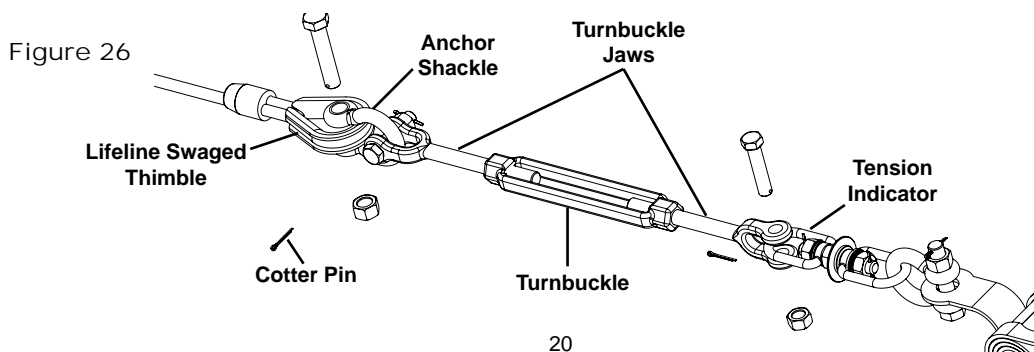

****Procedures C and D apply to the assembly required on the opposite lifeline end. Note: For multiple-span systems, be sure to feed cable through intermediate D-bolt anchors before proceeding with the following steps.**

C. Cable Lifeline to Thimble securing with Cable Clips *(see Figure 27)*

1. Feed cable around thimble, taking up as much slack in the lifeline as possible.
NOTE: Allow sufficient lifeline to enable attachment of the thimble to the D-bolt anchor using an anchor shackle.
2. Attach first cable clip as close to the thimble as possible. Attach two additional cable clips, spacing them 3" apart from the first cable clip and from each other. Note: There should be at least 8" of cable extending beyond the third cable clip (the clip furthest from the thimble). Torque cable clip nuts to 45 ft.-lbs.

Figure 27

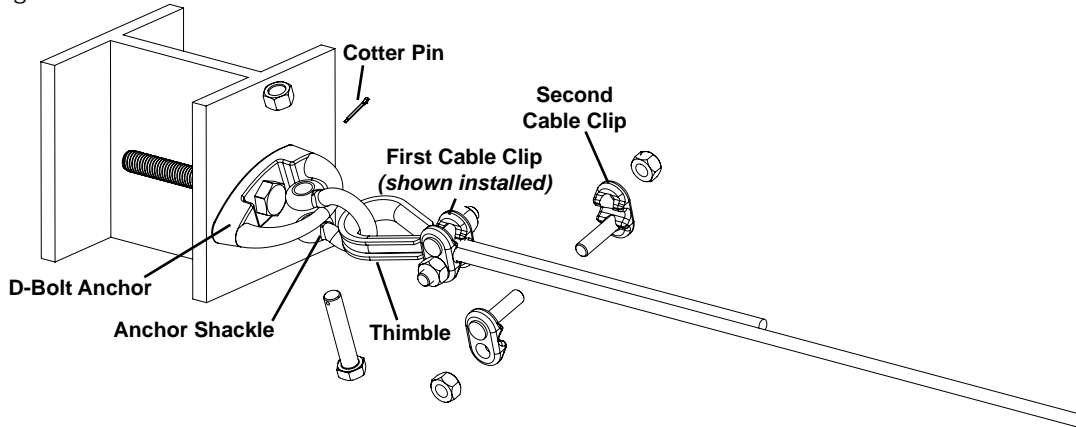
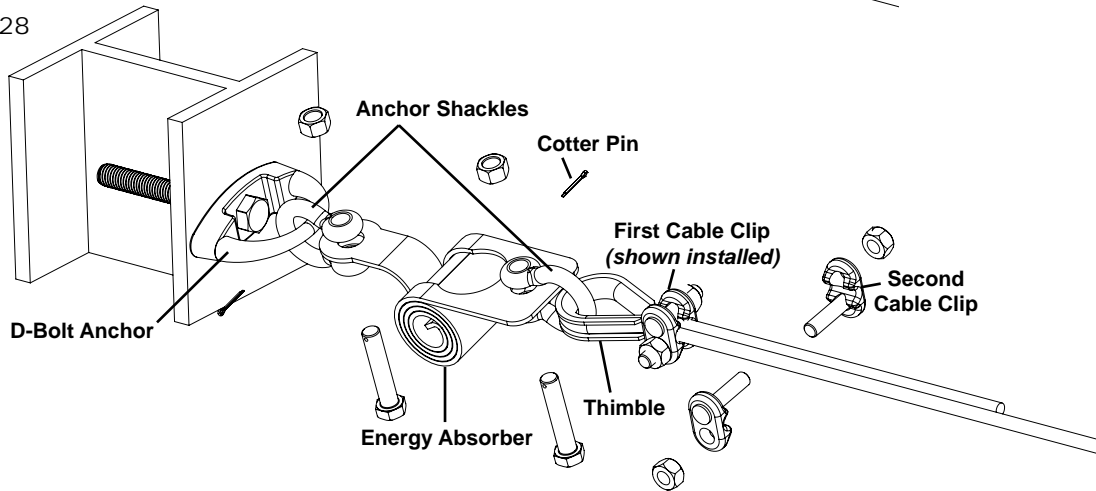

Figure 28



D. Thimble to D-Bolt Anchor using Anchor Shackle *(Single-Span Systems only – see Figure 27)*

1. Remove cotter pin, nut and bolt from anchor shackle.
2. Position anchor shackle through thimble and align the shackle with the D-bolt anchor.
3. Insert bolt completely through shackle and D-bolt anchor, attach nut and tighten snugly using a 3/4" wrench and socket.
4. Insert the cotter pin into the end of the bolt and bend slightly to prevent the pin from backing out.

OR

Energy Absorber to Thimble and D-Bolt Anchor using Anchor Shackles *(Multiple-Span Systems only – see Figure 28)*

1. Remove cotter pin, nut and bolt from anchor shackle.
2. Position anchor shackle through thimble and align the shackle bolt holes with the hole on either end of the shock absorber.
3. Insert bolt completely through shackle and shock absorber, attach nut and tighten snugly using a 3/4" wrench and socket.
4. Insert the cotter pin into the end of the bolt and bend slightly to prevent the pin from backing out.
5. Connect other anchor shackle to opposite end of shock absorber assembly and to D-bolt anchor using the same procedure.

12.3 Tensioning Horizontal Lifeline

IMPORTANT: It is essential that the lifeline be properly tensioned before use. Failure to do so will affect fall clearance requirements and the potential fall forces which may be imposed upon the worker and the system.

1. To prevent the lifeline from twisting while tensioning, hold the turnbuckle jaw at the lifeline thimble end while tightening the turnbuckle body. As the lifeline is tensioned, the jaws (threaded studs) will draw toward one another (see Figure 29).
2. At the correct tension, the tension indicator disk will spin freely by hand.

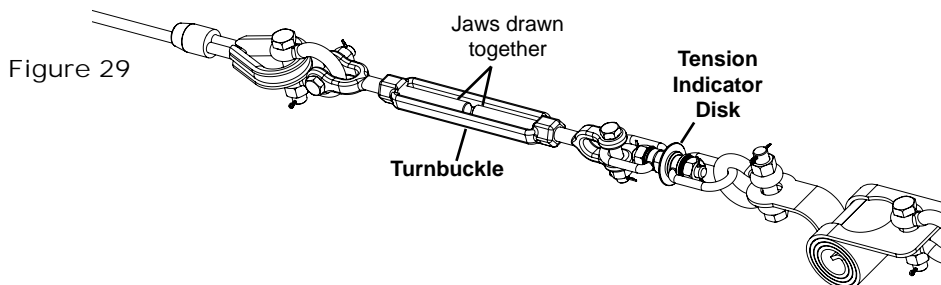

Before using the system, double-check all fasteners to ensure that they are installed correctly and to required specifications.

13.0 Operation/Use of Horizontal Lifeline

1. Inspect all equipment before use according to the manufacturer's instructions.
2. Properly fit the full-body harness. Refer to the donning instructions provided with the harness. Connect the shock-absorbing lanyard or self-retracting lifeline/fall limiter to the back D-ring of the harness.
3. Ensure that the structure being worked on is properly supported before connecting to the horizontal lifeline. Use necessary fall protection equipment while approaching the horizontal lifeline.
4. Connect the snap hook onto the cable lifeline. The snap hook must be connected to the lifeline at all times. To navigate the snap hook through pass-thru brackets (if applicable), follow the diagram (see Figure 30) as shown.
5. Never allow more than two workers to be connected between stanchions or anchors at one time, and never allow more than six workers per system.

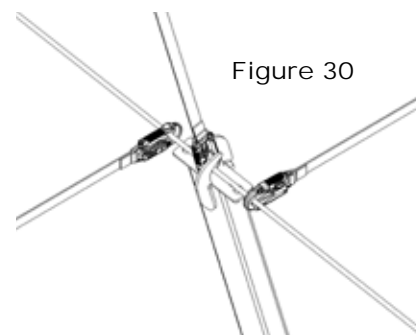

14.0 Fall Clearance

Always know your fall clearance before proceeding with the use of a horizontal lifeline system. Fall clearance calculations are based on the application of the system (steel or concrete mounted), length of span between stanchions, connecting device being used, and number of workers connected to the system within a span. Calculations are made from the working surface of the horizontal lifeline system. Miller Fall Protection recommends a 3ft (.9m) safety factor be added to all fall clearance calculations.

Total Fall Clearance Required* [ft.-in. (m)] for One or Two Workers Connected to Steel Mounted SkyGrip System (within a span)

Span Length [ft (m)]	Length of Lanyard								SRL/Fall Limiter**	
	3ft (.9m)		4ft (1.2m)		5ft (1.5m)		6ft (1.8m)			
	One Worker	Two Workers	One Worker	Two Workers	One Worker	Two Workers	One Worker	Two Workers	One Worker	Two Workers
0-10 (0-3m)	9'-8" (3m)	10'-8" (3.3m)	10'-8" (3.3m)	11'-8" (3.6m)	11'-8" (3.6m)	12'-8" (3.9m)	12'-8" (3.9m)	13'-8" (4.2m)	9'-8" (3m)	10'-8" (3.3m)
10-20 (3-6.1m)	10'-9" (3.3m)	11'-11" (3.6m)	11'-9" (3.6m)	12'-11" (3.9m)	12'-9" (3.9m)	13'-11" (4.2m)	13'-9" (4.2m)	14'-11" (4.6m)	10'-9" (3.3m)	11'-11" (3.6m)
20-30 (6.1-9.1m)	11'-8" (3.6m)	13'-2" (4m)	12'-8" (3.9m)	14'-2" (4.3m)	13'-8" (4.2m)	15'-2" (4.6m)	14'-8" (4.5m)	16'-2" (4.9m)	11'-8" (3.6m)	13'-2" (4m)
30-40 (9.1-12.2m)	12'-9" (3.9m)	14'-5" (4.4m)	13'-9" (4.2m)	15'-5" (4.7m)	14'-9" (4.5m)	16'-5" (5m)	15'-9" (4.8m)	17'-5" (5.3m)	12'-9" (3.9m)	14'-5" (4.4m)
40-50 (12.2-15.2m)	13'-8" (4.2m)	15'-8" (4.8m)	14'-8" (4.5m)	16'-8" (5.1m)	15'-8" (4.8m)	17'-8" (5.4m)	16'-8" (5.1m)	18'-8" (5.7m)	13'-8" (4.2m)	15'-8" (4.8m)
50-60 (15.2-18.3m)	14'-9" (4.5m)	17'-1" (5.2m)	15'-9" (4.8m)	18'-1" (5.5m)	16'-9" (5.1m)	19'-1" (5.8m)	17'-9" (5.4m)	20'-1" (6.1m)	14'-9" (4.5m)	17'-1" (5.2m)

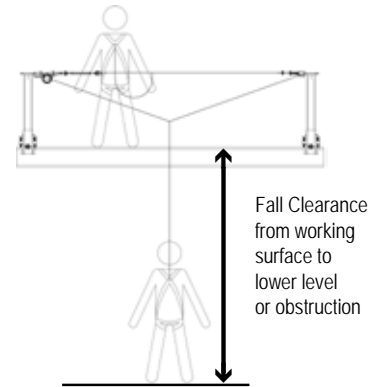

*Miller Fall Protection recommends that a 3ft (.9m) safety factor be added to the above fall clearance calculations.

**The SRL/Fall Limiter clearance calculations assume the worker is located directly adjacent to the lifeline where the SRL/Fall Limiter is connected. Working away from the point of attachment increases fall clearance.

Total Fall Clearance Required* [ft.-in. (m)] for One or Two Workers Connected to Concrete Mounted SkyGrip System (within a span)

Span Length [ft (m)]	Length of Lanyard								SRL/Fall Limiter**	
	3ft (.9m)		4ft (1.2m)		5ft (1.5m)		6ft (1.8m)			
	One Worker	Two Workers	One Worker	Two Workers	One Worker	Two Workers	One Worker	Two Workers	One Worker	Two Workers
0-10 (0-3m)	9'-8" (3m)	11'-4" (3.5m)	10'-8" (3.3m)	12'-4" (3.8m)	11'-8" (3.6m)	13'-4" (4m)	12'-8" (3.9m)	14'-4" (4.4m)	9'-8" (3m)	11'-4" (3.5m)
10-20 (3-6.1m)	10'-9" (3.3m)	12'-5" (3.8m)	11'-9" (3.6m)	13'-5" (4.1m)	12'-9" (3.9m)	14'-5" (4.4m)	13'-9" (4.2m)	15'-5" (4.7m)	10'-9" (3.3m)	12'-5" (3.8m)
20-30 (6.1-9.1m)	11'-8" (3.6m)	13'-5" (4.1m)	12'-8" (3.9m)	14'-5" (4.4m)	13'-8" (4.2m)	15'-5" (4.7m)	14'-8" (4.5m)	16'-5" (5m)	11'-8" (3.6m)	13'-5" (4.1m)
30-40 (9.1-12.2m)	12'-9" (3.9m)	14'-5" (4.4m)	13'-9" (4.2m)	15'-5" (4.7m)	14'-9" (4.5m)	16'-5" (5m)	15'-9" (4.8m)	17'-5" (5.3m)	12'-9" (3.9m)	14'-5" (4.4m)
40-50 (12.2-15.2m)	13'-8" (4.2m)	15'-5" (4.7m)	14'-8" (4.5m)	16'-5" (5m)	15'-8" (4.8m)	17'-5" (5.2m)	16'-8" (5.1m)	18'-5" (5.6m)	13'-8" (4.2m)	15'-5" (4.7m)
50-60 (15.2-18.3m)	14'-9" (4.5m)	16'-6" (5m)	15'-9" (4.8m)	17'-6" (5.3m)	16'-9" (5.1m)	18'-6" (5.6m)	17'-9" (5.4m)	19'-6" (5.9m)	14'-9" (4.5m)	16'-6" (5m)

Fall Clearance for Horizontal Lifeline Kits & Stainless Steel System

The following fall clearance chart applies when using SkyGrip Horizontal Lifeline Kits or the SkyGrip Stainless Steel System. Because these are mounted using anchorage connectors and may be mounted at different heights over the working surface, calculations are made from the lifeline. Miller Fall Protection recommends a 3ft (.9m) safety factor be added to all fall clearance calculations.

Total Fall Clearance Required* [ft.-in. (m)] for One or Two Workers using SkyGrip HLL Kits or the SkyGrip Stainless Steel System

Span Length [ft (m)]	Length of Lanyard								SRL/Fall Limiter**	
	3ft (.9m)		4ft (1.2m)		5ft (1.5m)		6ft (1.8m)			
	One Worker	Two Workers	One Worker	Two Workers	One Worker	Two Workers	One Worker	Two Workers	One Worker	Two Workers
0-10 (0-3m)	13'-2" (4m)	14'-1" (4.3m)	14'-2" (4.3m)	15'-1" (4.6m)	15'-2" (4.6m)	16'-1" (4.9m)	16'-2" (4.9m)	17'-1" (5.2m)	13'-2" (4m)	14'-1" (4.3m)
10-20 (3-6.1m)	13'-11" (4.2m)	15'-0" (4.6m)	14'-11" (4.5m)	16'-0" (4.9m)	15'-11" (4.9m)	17'-0" (5.2m)	16'-11" (5.2m)	18'-0" (5.5m)	13'-11" (4.2m)	15'-0" (4.6m)
20-30 (6.1-9.1m)	14'-8" (4.5m)	16'-0" (4.9m)	15'-8" (4.8m)	17'-0" (5.2m)	16'-8" (5.1m)	18'-0" (5.5m)	17'-8" (5.4m)	19'-0" (5.8m)	14'-8" (4.5m)	16'-0" (4.9m)
30-40 (9.1-12.2m)	15'-5" (4.7m)	16'-11" (5.2m)	16'-5" (5m)	17'-11" (5.5m)	17'-5" (5.3m)	18'-11" (5.8m)	18'-5" (5.6m)	19'-11" (6.1m)	15'-5" (4.7m)	16'-11" (5.2m)
40-50 (12.2-15.2m)	16'-2" (4.9m)	17'-11" (5.5m)	17'-2" (5.2m)	18'-11" (5.8m)	18'-2" (5.5m)	19'-11" (6.1m)	19'-2" (5.8m)	20'-11" (6.4m)	16'-2" (4.9m)	17'-11" (5.5m)
50-60 (15.2-18.3m)	16'-11" (5.2m)	18'-10" (5.7m)	17'-11" (5.5m)	19'-10" (6m)	18'-11" (5.8m)	20'-10" (6.4m)	19'-11" (6.1m)	21'-10" (6.7m)	16'-11" (5.2m)	18'-10" (5.7m)

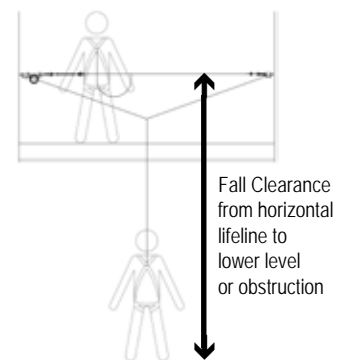

15.0 Training

It is the responsibility of the user and the purchaser of this equipment to assure they are familiar with these instructions and are trained in the proper use, installation, operation, maintenance and limitations of this product. Training should be conducted periodically and without exposing the trainee to a fall hazard.

Training is an integral part of our Total Solution in fall protection, since no fall protection equipment – regardless of how effective – can save an employee who is not trained in its use. To meet this crucial requirement, Miller Training provides the knowledge and skills necessary to achieve a safe, more productive work environment. For more information on Miller Training, contact a representative today: 800.873.5242.

16.0 Inspection and Maintenance

Inspection

The Miller SkyGrip System is designed for today's rugged work environments. To maintain its service life and high performance, all components should be inspected frequently. Visually inspect before each use. Regular inspection by a competent person for wear, damage or corrosion should be a part of your safety program. **Replace equipment if any of the defective conditions explained in this manual are found.**

Before each use, visually inspect for the following:

- Inspect for physical damages, wear and corrosion.
- Inspect for crimped fittings, cracks or any signs of loading.
- Inspect the cable lifeline for cuts, frays, kinks, broken strands or other signs of unusual wearing patterns.

[CAUTION: Always wear gloves when inspecting wire rope!]

- Inspect for malfunctioning or missing components. [For replacement parts call: 800.873.5242]

Cleaning and Storage

Basic care of all Miller Fall Protection equipment will prolong the life of the unit and will contribute toward the performance of its vital safety function. Proper storage and maintenance after use are as important as cleansing the equipment of dirt, corrosives, or contaminants. Storage areas should be clean, dry and free of exposure to fumes or corrosive elements. Wipe off all surface dirt with a sponge dampened in plain water. Squeeze the sponge dry. Dip the sponge in a mild solution of water and commercial soap or detergent. Work up a thick lather, with a vigorous back and forth motion. Then wipe dry with a clean cloth. Store in a clean, dry area when not in use.

Servicing

Servicing must only be carried out by a qualified person trained in the inspection and replacement of the system. A record log of all servicing and inspection dates for this system should be maintained by the company safety officer. **This system and all components must be withdrawn from service if subjected to fall arresting forces.** Only original Miller Fall Protection replacement parts are approved for use in this device. Contact your Miller Fall Protection distributor or Miller Technical Services at 800.873.5242 if you have any questions.

Labels



MILLER
SkyGRIP™
Temporary Horizontal Lifeline System
Energy Absorber

⚠ WARNING!

- Only trained personnel are permitted to use this system.
- System must not be altered in any way.
- Inspect before each use according to manufacturer's instructions.
- Use caution when working in or near hazardous environments. Equipment must not be exposed to chemical, electrical or thermal sources which may affect the integrity of the system.
- If the energy absorber is subjected to fall arrest forces or if inspection reveals an unsafe condition, the energy absorber must be taken out of service.
- Personal fall protection—a full-body harness and shock-absorbing lanyard or self-retracting lifeline, which limits maximum fall arrest forces to 900lbf (4kN)—must be used with this system.
- A rescue plan, and the means to implement it, must be in place when using this equipment.
- Make only compatible connections.
- For use as an energy absorber for Miller approved Horizontal Lifeline Systems only.
- Do not use as a personal shock absorber in a fall arrest system.
- Maximum System Forces: 2,500lbf (11.1kN)
- HLL System Requirements: 1 energy absorber per single-span system, 2 energy absorbers per multi-span system.

⚠ WARNING! Manufacturer's instructions supplied with this product at the time of shipment must be followed. Failure to do so may result in serious injury or death. Contact Miller Fall Protection if instruction manual is needed.

ADVERTENCIA: Deben seguirse las instrucciones del fabricante provistas con este producto al momento de despacho. El no hacerlo puede resultar en lesiones graves o la muerte. Si se requiere el manual de instrucciones consulte con Miller Fall Protection.

AVERTISSEMENT: Vous devez respecter les instructions du fabricant que vous avez reçues avec le produit. Dans le cas contraire, vous risquez de blessures graves ou même la mort. Contactez Miller Fall Protection si vous avez besoin d'un nouveau manuel.

Material: Stainless Steel

MILLER
by SPERIAN

Sperian Fall Protection, Inc.
P.O. Box 271, 1345 15th Street
Franklin, PA 16323 USA
TOLL FREE 800-873-5242

Patent Pending LB973 Rev A

⚠ WARNING

Attach bracket to stanchion post using only approved fasteners provided.

Pin

Washer

Wire Pin

Patent Pending

LB974 REV A

Miller
SkyGRIP™
Temporary Horizontal Lifeline System

FAILURE TO OBSERVE INSTRUCTIONS
MAY RESULT IN SERIOUS OR FATAL INJURY

⚠ WARNING!

- Warnings and instructions must be read and understood prior to using the equipment.
- Only trained personnel are permitted to use this system.
- System must not be altered in any way.
- Inspect before each use according to manufacturer's instructions.
- Use caution when working in or near hazardous environments. Equipment must not be exposed to chemical, electrical or thermal sources which may affect the integrity of the system.
- If the system is subjected to fall arrest forces or if inspection reveals an unsafe condition, the system must be taken out of service.
- Personal fall protection—a full-body harness and shock-absorbing lanyard or self-retracting lifeline, which limits maximum fall arrest forces to 900 lbf (4kN)—must be used with this system.
- A rescue plan, and the means to implement it, must be in place when using this equipment.
- Make only compatible connections.

"TORQUE SPECIFICATIONS"
Combo Clamp & Turnbuckle: 405 lbf-ft
Cable Clip: 405 lbf-ft
Rubber Clamps (concrete only): 735 lbf-ft

TYPICAL SINGLE-SPAN SYSTEM FOR STEEL APPLICATIONS

TYPICAL MULTI-SPAN SYSTEM FOR STEEL APPLICATIONS

TYPICAL SINGLE-SPAN SYSTEM FOR CONCRETE APPLICATIONS

Max. Lifeline Span Between Stanchions: 60 ft (18.3m)
Max. Capacity Per Span: 2 Workers (310 lbs, 140 kg) each
Max. System Capacity (steel): 8 Workers (310 lbs, 140 kg) each
Max. System Capacity (concrete): 5 Workers (310 lbs, 140 kg) each

Total Fall Clearance Required* min. req. for Two Workers Connected to SkyGRIP System (within a span)

Span Length (ft/m)	60 ft (18.3m)		40 ft (12.2m)		20 ft (6.1m)	
	Steel	Concrete	Steel	Concrete	Steel	Concrete
60	10.0	10.0	10.0	10.0	10.0	10.0
40	10.0	10.0	10.0	10.0	10.0	10.0
20	10.0	10.0	10.0	10.0	10.0	10.0

*Calculations are made from the working surface of the horizontal lifeline system. Miller Fall Protection recommends a 3 ft (1 m) safety factor be added to all fall clearance calculations.

⚠ WARNING! MANUFACTURER'S INSTRUCTIONS SUPPLIED WITH THIS PRODUCT AT TIME OF SHIPMENT MUST BE FOLLOWED. FAILURE TO DO SO COULD RESULT IN SERIOUS INJURY OR DEATH.

ADVERTENCIA: DEBEN SEGUIRSE LAS INSTRUCCIONES DEL FABRICANTE PROVISTAS CON ESTE PRODUCTO AL MOMENTO DE DESPACHO. EL NO HACERLO PUEDE RESULTAR EN LESIONES GRAVES O LA MUERTE.

AVERTISSEMENT: VOUS DEVEZ RESPECTER LES INSTRUCTIONS DU FABRICANT QUE VOUS AVEZ REÇUES AVEC LE PRODUIT. DANS LE CAS CONTRAIRE VOUS RISQUEZ DES BLESSURES GRAVES OU MÊME LA MORT.

INSPECTION LOG

NO.	DATE	BY	STATUS
1			
2			
3			
4			

MILLER
by SPERIAN

Sperian Fall Protection, Inc.
P.O. Box 271, 1345 15th Street
Franklin, PA 16323 USA
TOLL FREE 800-873-5242

LB973 Rev. A
10/17/2002

Inspection and Maintenance Log

Registre D'inspection et D'entretien
Registro de Inspección y Mantenimiento

DATE OF MANUFACTURE: _____
DATE DE FABRICATION / FECHA DE FABRICACIÓN

MODEL NUMBER: _____
NUMÉRO DE MODÈLE / NÚM. DE MODELO

DATE PURCHASED: _____
DATE D'ACHAT / FECHA DE COMPRA

INSPECTION DATE <small>DATE D'INSPECTION FECHA DE INSPECCIÓN</small>	INSPECTION ITEMS NOTED <small>POINTS NOTÉS LORS DE L'INSPECTION PUNTOS DE INSPECCIÓN RELEVANTES</small>	CORRECTIVE ACTION <small>ACTION CORRECTIVE MEDIDA CORRECTIVA</small>	MAINTENANCE PERFORMED <small>ENTRETIEN EFFECTUÉ MANTENIMIENTO REALIZADO</small>
Approved by: Approuvé par: Aprobado por:			
Approved by: Approuvé par: Aprobado por:			
Approved by: Approuvé par: Aprobado por:			
Approved by: Approuvé par: Aprobado por:			
Approved by: Approuvé par: Aprobado por:			
Approved by: Approuvé par: Aprobado por:			
Approved by: Approuvé par: Aprobado por:			
Approved by: Approuvé par: Aprobado por:			
Approved by: Approuvé par: Aprobado por:			



MILLER® FALL PROTECTION PRODUCTS
TOTAL SATISFACTION ASSURANCE

At Miller Fall Protection, we have been providing quality Miller brand fall protection equipment to millions of workers worldwide since 1945.

LIMITED LIFETIME WARRANTY
BACKED BY OVER 60 YEARS IN THE FALL PROTECTION BUSINESS

We sincerely believe that our fall protection equipment is the best in the world. Our products endure rigorous tests to ensure that the fall protection equipment you trust is manufactured to the highest standards. Miller fall protection products are tested to withstand normal wear and tear, but are not indestructible and can be damaged by misuse. Our Limited Lifetime Warranty does not apply to normal wear and tear or abusive treatment of the product.

In the unlikely event that you should discover defects in either workmanship or materials, under our Limited Lifetime Warranty, we will repair or replace the product at our expense. If a replacement is necessary and your product is no longer available, a comparable product will be substituted. Should a product issue surface, contact us at 800.873.5242.

Manufacturing specifications are subject to change without notice.

PRODUITS MILLER® FALL PROTECTION
ASSURANCE DE SATISFACTION TOTALE

Chez Miller Fall Protection, nous fournissons des équipements de protection contre les chutes de marque Miller de qualité à des millions de travailleurs dans le monde entier depuis 1945.

GARANTIE LIMITÉE À VIE
ASSURÉE GRÂCE À PLUS DE 60 ANS PASSÉS DANS LE DOMAINE DE LA PROTECTION CONTRE LES CHUTES

Nous croyons sincèrement que notre équipement de protection contre les chutes est le meilleur au monde. Nos produits sont soumis à des tests rigoureux, afin d'assurer que les équipements de protection contre les chutes dans lesquels vous avez confiance sont fabriqués selon les normes les plus exigeantes. Les produits de protection contre les chutes Miller sont soumis à des essais pour vérifier qu'ils résistent à une usure normale; ils ne sont cependant pas indestructibles et peuvent s'endommager en cas de mauvaise utilisation. Notre garantie limitée à vie ne s'applique pas à l'usure normale ou à un usage abusif du produit.

Dans le cas peu probable où vous découvririez des défauts, soit de fabrication, soit de matériau, dans le cadre de notre garantie à vie, nous réparerons ou remplacerons le produit à nos frais. En cas de remplacement, si votre produit n'est plus offert, vous recevrez un produit comparable. En cas de problème sur un produit, nous contacter au 800-873-5242.

Les caractéristiques de fabrication peuvent être modifiées sans préavis.

PRODUCTOS ANTICAÍDAS MILLER®
GARANTÍA DE SATISFACCIÓN TOTAL

En Miller Fall Protection, venimos suministrando desde 1945 los equipos de protección anticaídas con la calidad Miller a millones de trabajadores en todo el mundo.

GARANTÍA LIMITADA DE POR VIDA
NOS RESPALDAN MÁS DE 60 AÑOS EN LA FABRICACIÓN DE EQUIPO ANTICAÍDAS

Sinceramente creemos que su equipo de protección contra caídas es el mejor del mundo. Nuestros productos resisten rigurosas pruebas para garantizar que el equipo de protección contra caídas en el que usted confía está fabricado de conformidad con las normas más elevadas. Los productos anticaídas Miller son sometidos a pruebas para que resistan el desgaste normal, pero no son indestructibles y su incorrecta utilización puede dañarlos.

Nuestra Garantía limitada de por vida no se aplica al desgaste normal ni al maltrato del producto.

En el poco probable caso de que usted descubriera defectos de mano de obra o materiales, por nuestra Garantía limitada de por vida, repararemos o sustituiremos el producto por cuenta nuestra. Si un reemplazo es necesario y nuestro producto ya no está disponible, se lo sustituiremos por otro comparable.

En caso de que surja un problema con el producto, contáctenos al 800.873.5242.

Las especificaciones de fabricación están sujetas a modificaciones sin previo aviso.



Toll Free: 800.873.5242
Fax: 800.892.4078

Download this manual at: www.millerfallprotection.com
Téléchargez ce manuel à l'adresse: www.millerfallprotection.com
Puede bajar por Internet este manual en: www.millerfallprotection.com

Sperian Fall Protection, Inc.
P.O. Box 271, 1345 15th Street
Franklin, PA 16323 USA